



INSTALLATION INSTRUCTIONS

APPLICATION: MOUNT KIT / 1999-2006 TOYOTA TUNDRA EXTENDED CAB
2004-2006 TOYOTA TUNDRA DOUBLE CAB
APP PART # 22-1345

ITEM	QUANTITY	DESCRIPTION	TOOLS NEEDED
1	1	STEP BAR ASSEMBLY (SOLD SEPERATELY)	TORQUE WRENCH
2	2	MOUNTING BRACKET (DRIVERS SIDE)	RATCHET
3	2	MOUNTING BRACKET (PASSENGER SIDE)	3/4" SOCKET
4	1	LONG BOLT BLATE	10MM SOCKET
5	1	SHORT BOLT PLATE	
6	2	PLASTIC WASHER	
7	2	SPACER WASHER (YELLOW ZINC)	
8	2	1/2" HEX HEAD BOLT (YELLOW ZINC)	
9	4	1/2" FLAT WASHER (YELLOW ZINC)	
10	4	1/2" LOCK WASHER (YELLOW ZINC)	
11	4	1/2" HEX NUT (YELLOW ZINC)	
12	4	M6 BOLT PLATE (STAINLESS)	
13	4	M6 FLAT WASHER (STAINLESS)	
14	4	M6 NYLOCK NUT (STAINLESS)	

ANTI-SEIZE LUBRICANT MUST BE USED ON ALL STAINLESS STEEL FASTENERS TO PREVENT THREAD DAMAGE AND GALLING .

1. Remove all contents from box, verify all parts listed are present and free from damage. Carefully read and understand all instructions before attempting installation. (Note: Step bar and mount kit sold separately)
2. When inserting bolt plates into designated slots on Figure 1, thread plastic washer onto bolt plate so it doesn't fall. See Figure 1.
3. Install front and rear brackets as shown. Hand tighten. See Figure 1.
4. Slide M6 bolt plate in to step bar as shown. Place step bar on saddle with long step pad forward and end cap screw facing inward. Assemble with M6 fasteners. See Figures 2 and 3.
5. Make sure step bar and brackets are properly aligned and tighten fasteners. Recommended torque values are 64 FT.LBS for 1/2" fasteners and 8 FT.LBS. for M6 fasteners.

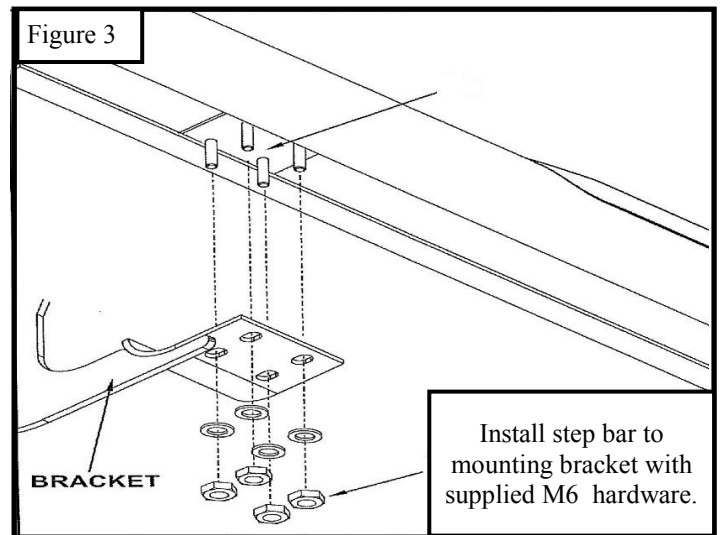
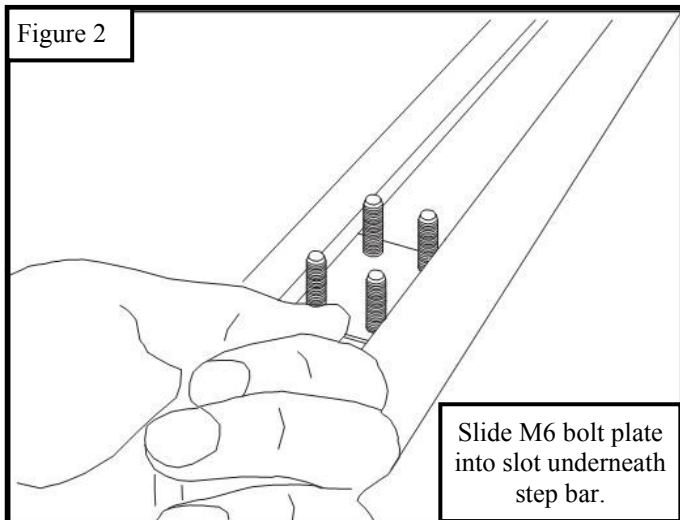
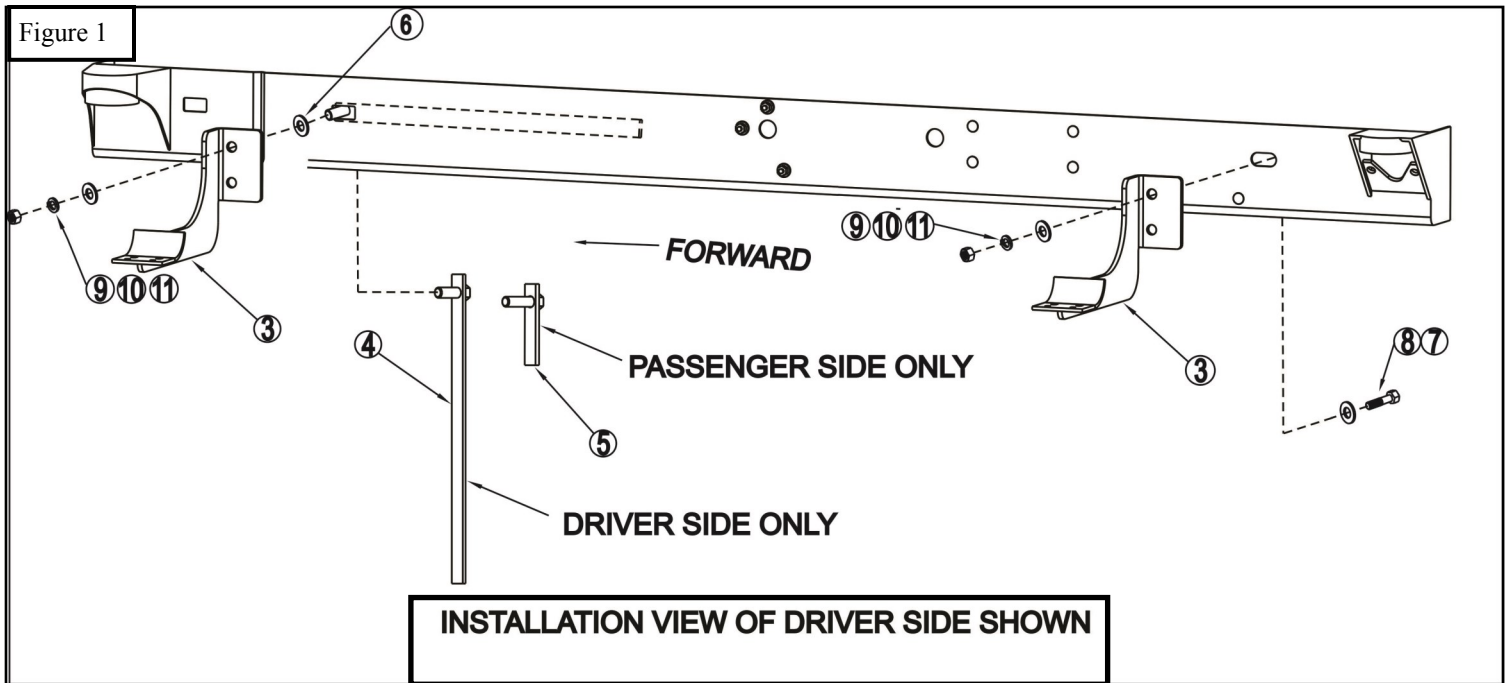

CARE INSTRUCTIONS

- REGULAR WAXING IS RECOMMENDED. DO NOT USE ANY TYPE OF POLISH OR WAX THAT MAY CONTAIN ABRASIVES.
- STAINLESS STEEL PRODUCTS CAN BE CLEANED WITH MILD SOAP AND WATER. STAINLESS STEEL POLISH SHOULD BE USED TO POLISH SMALL SCRATCHES.
- GLOSS BLACK FINISHES SHOULD BE CLEANED WITH MILD SOAP AND WATER.