

Westin

SIGNATURE OF QUALITY

AUTOMOTIVE PRODUCTS, INC.

INSTALLATION INSTRUCTIONS

APPLICATION: 2002-05 FORD EXPLORER (EXCLUDES SPORT TRAC & SPORT MODEL)

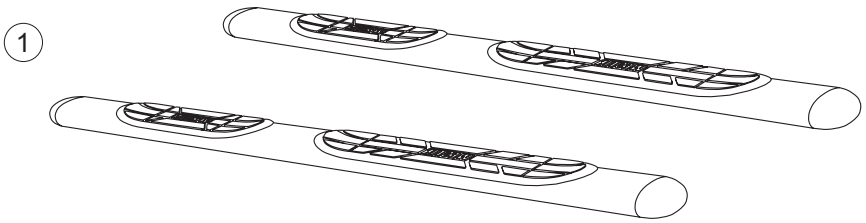
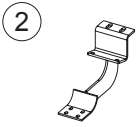
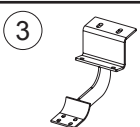
MOUNT KIT 22-1165 CHROME 22-0020 BLACK 22-0025			 
ITEM	QTY	CONTENTS	TOOLS
1	2	STEP BAR (PURCHASED SEPARATELY)	1/2" SOCKET 7/16" SOCKET 6" EXTENSION RATCHET TORQUE WRENCH
2	2	FRONT BRACKET	
3	2	REAR BRACKET	
4	12	5/16-18 X 1.00" HEX HEAD BOLT	
5	12	5/16" USS FLAT WASHER	
6	12	5/16" LOCK WASHER	
7	12	EXTRUDED U-NUT	
8	8	1/4-20 X .75 T-HEAD BOLT	
9	8	1/4" FLAT WASHER	
10	8	1/4-20 NYLON INSERT LOCK NUT	

- STEP 1. Remove contents from box and check for damage. Verify all parts are present. Read instructions completely before beginning.
- NOTE:** On vehicles with running boards, running boards must be removed. On vehicles without running boards, remove plastic trim and mount plates fastened to bottom of rocker panel. Use 7/16" socket to remove tin nuts and screwdriver to remove plastic clips holding mount plate.
- NOTE:** If installing oval tubes on vehicles equipped with factory step boards, rear air conditioning and heat, existing factory mounting hardware is used. The front bracket is placed over both mounting studs protruding from rocker panel, reuse factory nuts. If installing step bars on vehicles without step boards with rear air and heat, the plastic studs will need to be trimmed and a 5/16" hole drilled through the plastic where the stud was. Insert bolts through these holes.
- NOTE:** Be careful not to drill into the air conditioning lines.
- STEP 2. If installing Westin step boards on vehicles equipped with factory step boards, the existing factory hardware can be used. **SEE FIGURES 3 & 4.** If factory hardware is not present, use fasteners provided.
- STEP 3. Install extruded u-nuts as shown. **SEE FIGURES 1 & 2.**
- STEP 4. Loosely attach rear brackets to underside of body panel as shown. **SEE FIGURE 5.** **NOTE:** Rear brackets are wider than front brackets.
- STEP 5. Loosely attach front brackets to underside of body panel as shown. **SEE FIGURE 6.**
- NOTE:** For vehicles with rear A/C option, be careful of refrigeration lines when installing brackets on passenger side.
- STEP 6. Slide T-head bolts on step bar as shown (2 per slot, 4 per bar). Place step bar on saddle with long step pad forward and end cap screw facing inward. Assemble with 1/4" fasteners. **SEE FIGURES 7 AND 8.**
- STEP 7. Make sure step bar and brackets are properly aligned and tighten fasteners. Recommended torque values are 15 FT.LBS. for 5/16" fasteners and 7 FT.LBS. for 1/4" fasteners.

FINISH PROTECTION

Westin products have a high quality finish that must be cared for like any other exposed finish on the vehicle. Protect the finish with a non-abrasive automotive wax, (e.g. Pure Carnauba) on a regular basis. The use of any soap, polish or wax that contains an abrasive is detrimental, as the compounds scratch the finish and open it to corrosion.

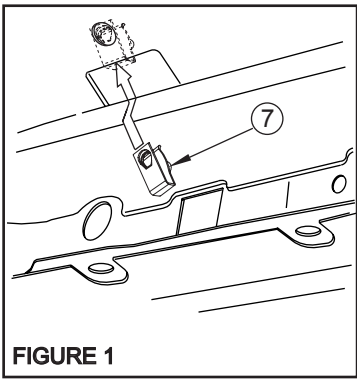

FIGURE 1

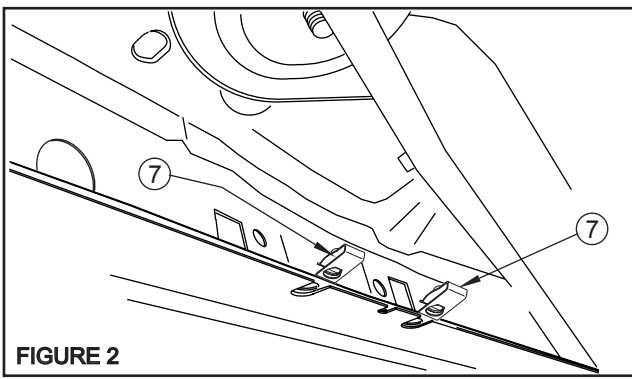

FIGURE 2

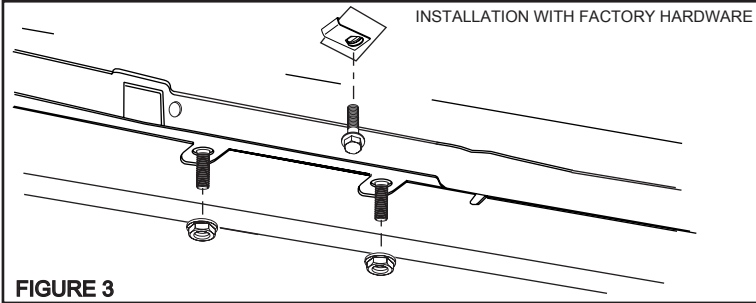

FIGURE 3

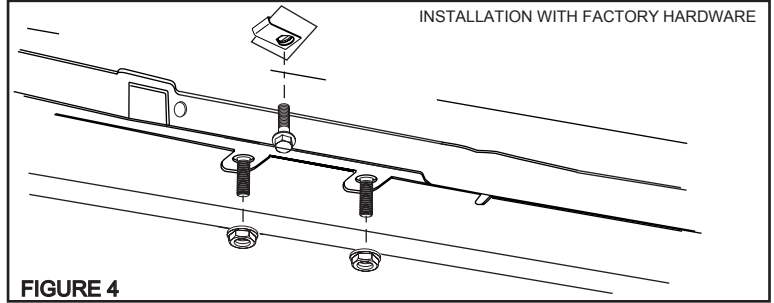

FIGURE 4

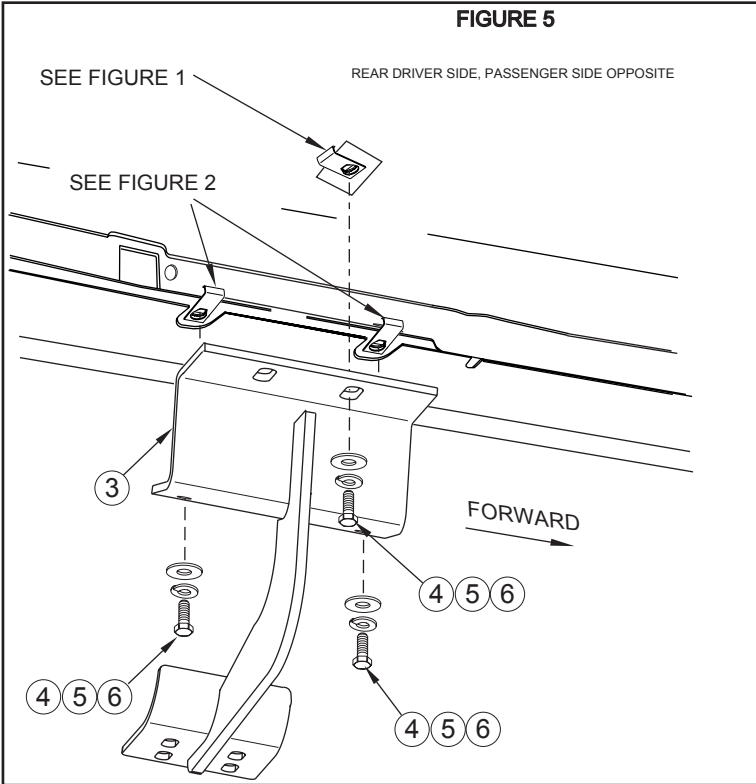

FIGURE 5

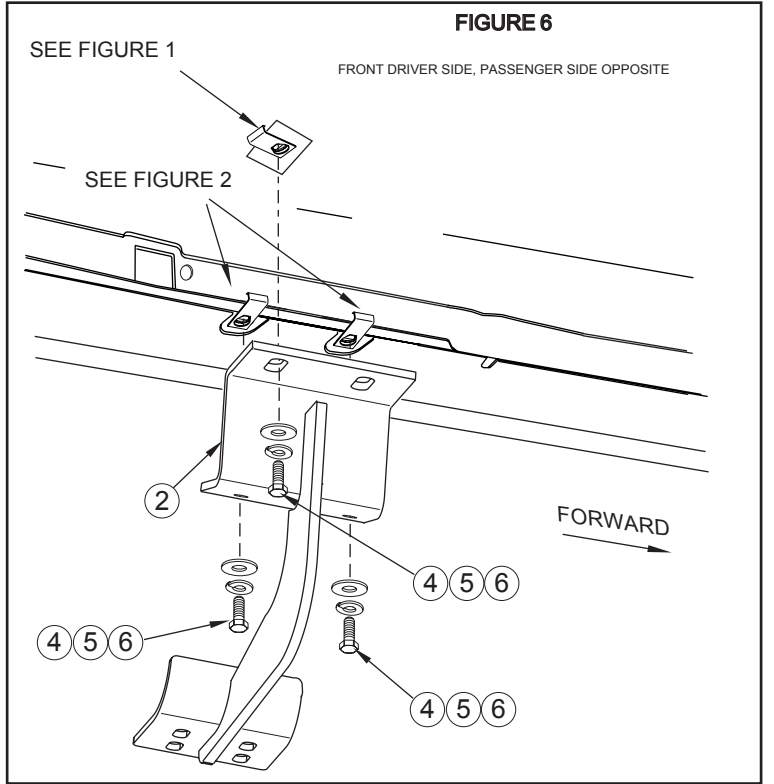

FIGURE 6

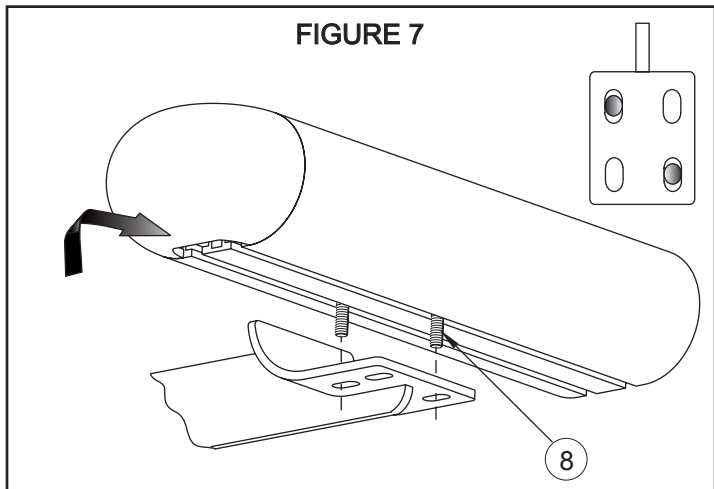

FIGURE 7

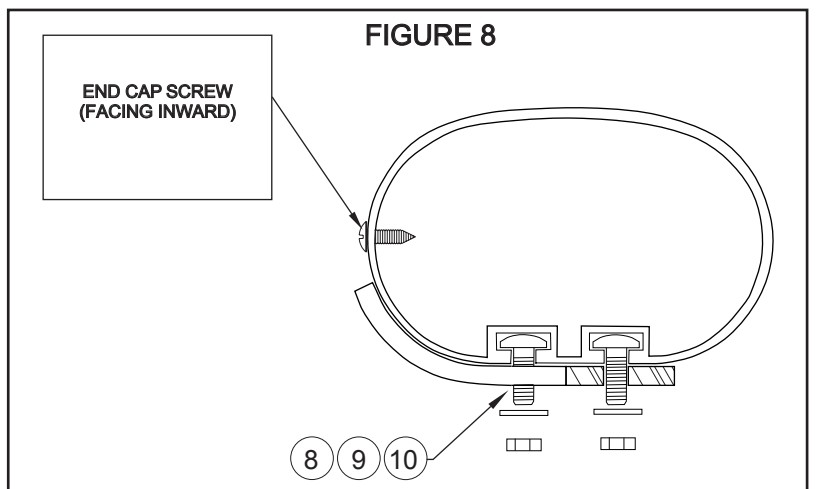

FIGURE 8