

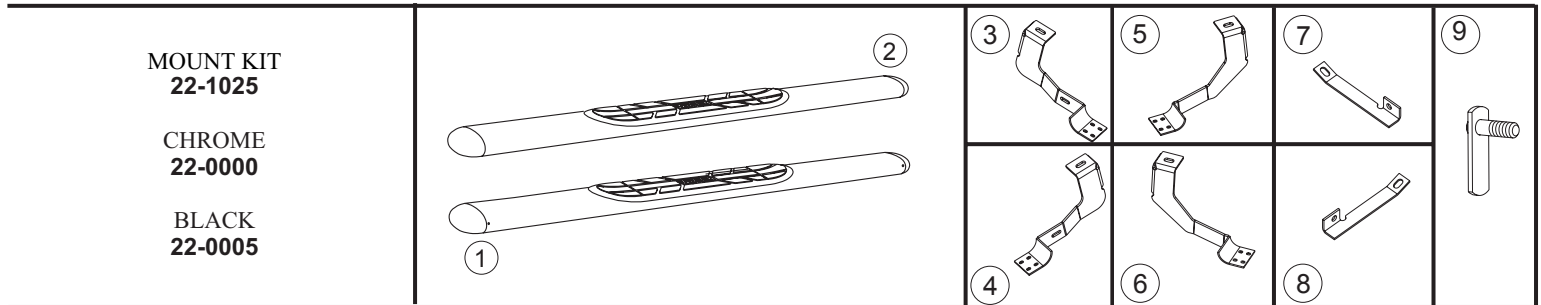

# INSTALLATION INSTRUCTIONS

APPLICATION: 2002-07 DODGE RAM 1500; 2003-07 RAM 2500/3500 REGULAR CAB  
2008 DODGE RAM 4500/5500 REGULAR CAB

AUTOMOTIVE PRODUCTS, INC.



ITEM	QTY	CONTENTS	TOOLS
1,2	2	STEP BAR, PASSENGER (1) AND DRIVER (2) (PURCHASED SEPARATELY)	3/4" SOCKET 9/16" SOCKET 9/16" WRENCH 7/16" SOCKET 18MM SOCKET RATCHET TORQUE WRENCH
3,4	2	FRONT BRACKET, PASSENGER (3) AND DRIVER (4)	
5,6	2	REAR BRACKET, PASSENGER (5) AND DRIVER (6)	
7,8	2	SUPPORT BRACE, PASSENGER (7) AND DRIVER (8)	
9	2	BOLT PLATE ASSEMBLY	
10	4	M12-1.75 X 120 MM HEX HEAD BOLT	
11	4	1/2" FLAT WASHER	
12	4	1/2" LOCK WASHER	
13	2	3/8-16 X 1.25" HEX HEAD BOLT	
14	6	3/8" FLAT WASHER	
15	4	3/8" LOCK WASHER	
16	4	3/8-16" HEX NUT	
17	2	PLASTIC WASHER	
18	8	1/4-20 X .75 T-HEAD BOLT	
19	8	1/4" FLAT WASHER	
20	8	1/4-20 NYLON INSERT LOCK NUT	

- STEP 1. Remove contents from box and check for damage. Verify all parts are present. Read instructions completely before beginning.
- STEP 2. Remove existing body mount bolts as shown. Existing body mount bolts will not be used. **SEE FIGURES 2 AND 3.**
- STEP 3. Install front and rear brackets as shown. Hand tighten. **SEE FIGURES 2 AND 3.**
- STEP 4. Attach plastic washer to bolt plate. Insert bolt plate as shown. **SEE FIGURE 1.**
- STEP 5. Attach support braces as shown. Hand tighten. Be sure bolt plate does not rotate out of hole by holding with small screwdriver until it is snug. **SEE FIGURE 2.**
- STEP 6. Slide T-head bolts on step bar as shown (2 per slot, 4 per bar). Place step bar on saddle with long step pad forward and end cap screw facing inward. Assemble with 1/4" fasteners. **SEE FIGURES 4 AND 5.**
- STEP 7. Make sure step bar and brackets are properly aligned and tighten fasteners. Recommended torque values are 63 FT.LBS for M12 fasteners, 26 FT.LBS. for 3/8" fasteners and 7 FT.LBS. for 1/4" fasteners.

#### FINISH PROTECTION

Westin products have a high quality finish that must be cared for like any other exposed finish on the vehicle. Protect the finish with a non-abrasive automotive wax, (e.g. Pure Carnauba) on a regular basis. The use of any soap, polish or wax that contains an abrasive is detrimental, as the compounds scratch the finish and open it to corrosion.

