

INSTALLATION INSTRUCTIONS

APPLICATION: 2009-14 FORD F150 SUPER CREW/2009-14 FORD F150 SUPER CAB
APP PART # 21-23510, 21-23515, 21-23520, 21-23525,
21-53510, 21-53515, 21-53520, 21-53525
PRO TRAXX STEP BARS

ITEM	QUANTITY	DESCRIPTION	TOOLS NEEDED
1,2	2	STEP BARS	13MM SOCKET
3	3	DRIVERS SIDE MOUNTING BRACKETS	13MM WRENCH
4	3	PASSENGER SIDE MOUNTING BRACKETS	ALLEN KEY (INCLUDED)
5	12	M8 NUT CLIPS	RATCHET
6	24	M8 HEX HEAD BOLT	TORQUE WRENCH
7	12	M8 FLAT WASHERS	
8	24	M8 LARGE FLAT WASHERS	
9	24	M8 LOCK WASHERS	
10	12	M8 HEX NUTS	
11	12	M10 BUTTON HEAD BOLTS (Stainless Steel)	
12	12	M10 FLAT WASHERS (Stainless Steel)	
13	12	M10 TOOTHED LOCK WASHERS (Stainless Steel)	

ANTI-SEIZE LUBRICANT MUST BE USED ON ALL STAINLESS STEEL FASTENERS TO PREVENT THREAD DAMAGE AND GALLING

1. Remove contents from box, verify if all parts listed are present and free from damage. Carefully read and understand all instructions before attempting installation.
2. Starting on the drivers side rocker panel, locate a piece of black tape. Remove the tape to reveal a rectangle hole. Take (2) M8 nut clips (*item 5*) and place them over the two round holes located vertically into the rocker panel. **Fig. 1**
3. Take the drivers side front mounting bracket (*item 3*), and attach it to the previously installed nut clips using (2) M8 hex head bolts (*item 6*), (2) M8 lock washers (*item 9*), and (2) M8 flat washers (*item 8*). *Do not fully tighten at this time, the cradles will face the rear of the vehicle.* **Fig. 2**
4. Attach the mounting bracket to the bottom holes in the rocker panel using (2) M8 hex head bolts (*item 6*), (2) M8 large flat washers (*item 8*), (2) M8 flat washers (*item 7*), (2) M8 lock washers (*item 9*), and (4) M8 hex nuts (*item 10*). *Do not fully tighten at this time.* **Fig. 4 & 5**
5. Repeat steps 2-4 for the center and rear mounting brackets. For SuperCrew p/n 21-23520, 21-23525, 21-53520 & 21-53525, the center brackets will mount only using (1) M8 nut clip (*item 5*). **Fig. 3**
6. Take the drivers side step bar and place it onto the mounting bracket cradles; align the step bars with the mounting holes in the brackets and attach using (6) M10 button head bolts (*item 11*), (6) M10 toothed lock washers (*item 13*), and (6) M10 flat washers (*item 12*). **Fig. 6** *Do not fully tighten at this time.*
7. Align and adjust the step bar as needed then fully tighten all hardware at this time. Torque all M8 hardware to 25 ft lbs , and M10 stainless hardware to 20 ft lbs
8. Repeat steps 2-7 for the passenger side.

CARE INSTRUCTIONS

- REGULAR WAXING IS RECOMMENDED. DO NOT USE ANY TYPE OF POLISH OR WAX THAT MAY CONTAIN ABRASIVES
- STAINLESS STEEL PRODUCTS CAN BE CLEANED WITH MILD SOAP AND WATER. STAINLESS STEEL POLISH SHOULD BE USED TO POLISH SMALL SCRATCHES.
- GLOSS BLACK FINISHES SHOULD BE CLEANED WITH MILD SOAP AND WATER

Driver's side exploded view

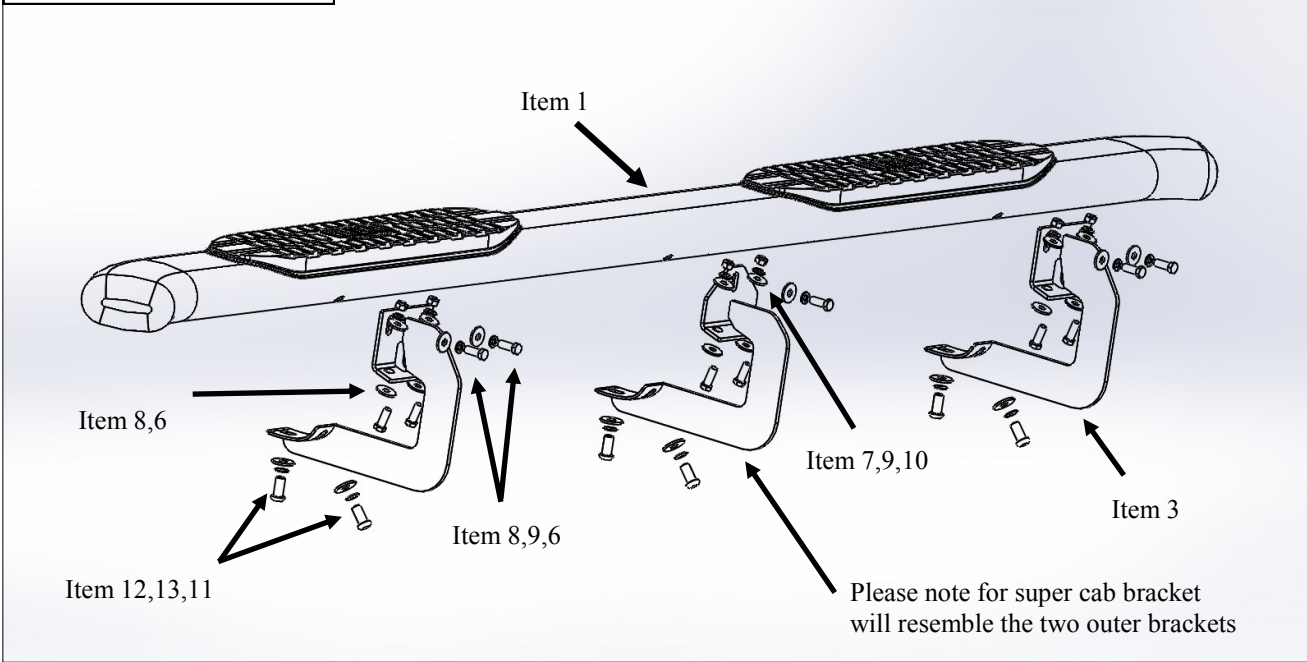

Remove tape & insert M8 nut clips



Attach the mounting bracket using M8 hardware

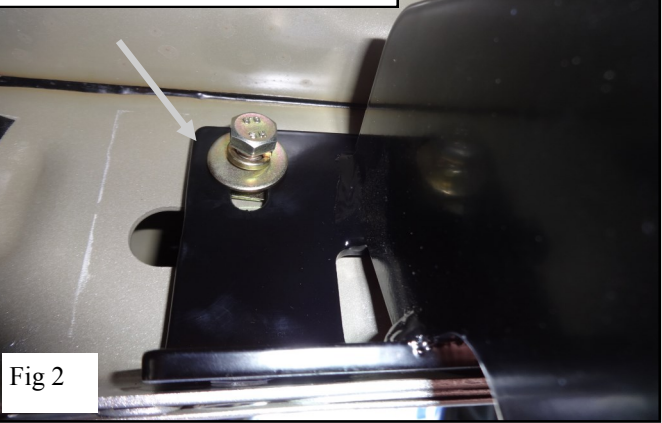

(2) M8 hex head bolts, (2) M8 large flat washers



