



INSTALLATION INSTRUCTIONS

APPLICATION: STEP BAR / 2015 & UP CHEVY COLORADO & GMC CANYON
 APP PART # 21-4000 , 21-4005 , 21-4010 , 21-4015
 # 23-4000 , 23-4005 , 23-4010 , 23-4015

ITEM	QUANTITY	DESCRIPTION	TOOLS NEEDED
1	1	DRIVER SIDE STEP BAR ASSEMBLY	RATCHET
2	1	PASSENGER SIDE STEP BAR ASSEMBLY	UTILITY KNIFE
3	1	DRIVER SIDE FRONT MOUNTING BRACKET	18MM SOCKET
4	1	PASSENGER SIDE FRONT MOUNTING BRACKET	15MM SOCKET
5	1	DRIVER SIDE REAR MOUNTING BRACKET	14MM SOCKET
6	1	PASSENGER SIDE REAR MOUNTING BRACKET	21MM SOCKET
7	2	FRONT SUPPORT STRAP	3/4 SOCKET
8	4	M8 BOLT PLATE	ALLEN WRENCH
9	4	1/2" HEX HEAD SCREW (YELLOW ZINC)	TORQUE WRENCH
10	4	1/2" FLAT WASHER 27MM OD (YELLOW ZINC)	SOCKET EXTENS.
11	4	1/2" SPLIT LOCK WASHER (YELLOW ZINC)	PRY TOOL
12	4	M8 U-CLIP NUT (YELLOW ZINC)	
13	4	M8 HEX NUT (YELLOW ZINC)	
14	6	M8 FLAT WASHER 24MM OD (YELLOW ZINC)	
15	8	M8 SPLIT LOCK WASHER (YELLOW ZINC)	
16	4	M8 HEX HEAD SCREW (YELLOW ZINC)	
17	2	M8 FLAT WASHER 16MM OD (YELLOW ZINC)	
18	4	M6 BUTTON HEAD SCREW (BLACK ZINC)	
19	8	M6 FLAT WASHER 18MM OD (BLACK ZINC)	
20	4	M6 SPLIT LOCK WASHER (BLACK ZINC)	
21	4	M6 HEX NUT (BLACK ZINC)	
22	2	M10 BUTTON HEAD BOLT (STAINLESS), CREW CAB ONLY	
23	2	M10 FLAT WASHER 20MM (STAINLESS), CREW CAB ONLY	
24	2	M10 SPLIT LOCK WASHER (STAINLESS), CREW CAB ONLY	
25	2	ROUND SPACER	
26	2	MIDDLE SUPPORT STRAP, CREW CAB ONLY	
27	1	M8 FISH WIRE	

ANTI-SEIZE LUBRICANT MUST BE USED ON ALL STAINLESS STEEL FASTENERS TO PREVENT THREAD DAMAGE AND GALLING .

1. Remove contents from box, verify if all parts listed are present and undamaged. Carefully read and understand all instructions before attempting installation.
2. Remove plastic cover by front mud guard, see Figure 1.
3. Remove factory M6 hardware and replace with supplied M6 button head bolts, See Figure 2 and 5.

4. Remove front rubber covers from rocker panel then install supplied M8 U-Clip Nuts into the designated areas, see Figure 3 and 4. (Note: U-Clips only used on front mounting location.)
5. Loosely install Front Mounting Bracket to the rocker panel with supplied M6 hardware by placing the bracket flush with factory welded nuts, see Front Assembly and Figure 5. (Note: Do not remove factory welded nuts.)
6. Loosely install Front Mounting Bracket to M8 U-Clip Nuts with supplied M8 hardware, see Front Assembly and Figure 4.
7. Remove the factory bolt from the front rubber body mount. Loosely install Front Support Strap to body mount using factory bolt. see Figure 5 and Front Assembly.
8. On the rear of vehicle remove rubber covers on the rocker panel, similar to Figure 3.
9. Loosely install Rear Mounting Bracket using supplied M8 Bolt Plates and M8 hardware. Guide M8 bolt plates through the revealed holes beneath the rubber covers on rocker panel. See Rear Assembly, Figure 7, 8, and 9. (Note: To install M8 Bolt Plates, you may either try by hand or using the supplied fish wire, see Figure 10.)
10. Loosely install Step Bar Assembly to Front and Rear Mounting Brackets using supplied 1/2" hardware, see Front Assembly and Rear Assembly.
11. **For crew cab vehicles** remove factory bolt from center body mount similar to Figure 6. Loosely install Center Support Strap to body mount and to step bar with the factory bolt and supplied M10 hardware, see Figure 11.
12. Align and adjust the Step Bar as necessary. Tighten and torque all hardware : M6 to 7 ft-lbs., M8 to 15 ft-lbs., M10 to 20-25 ft-lbs., 1/2 to 45-50 ft-lbs.
13. Reinstall all plastic covers removed during installation process.

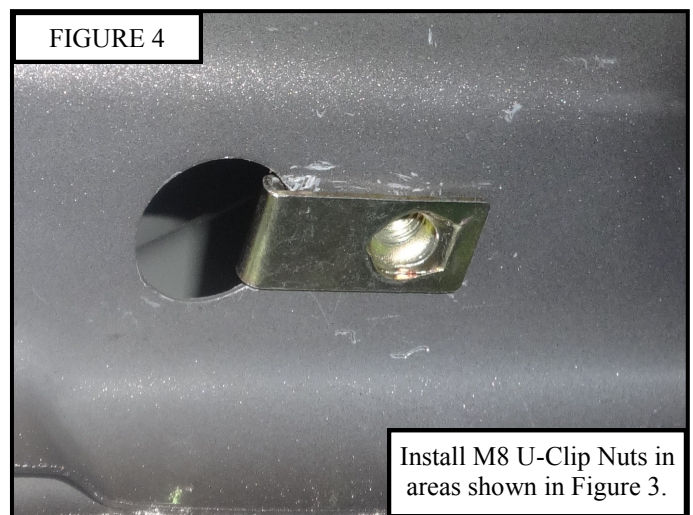
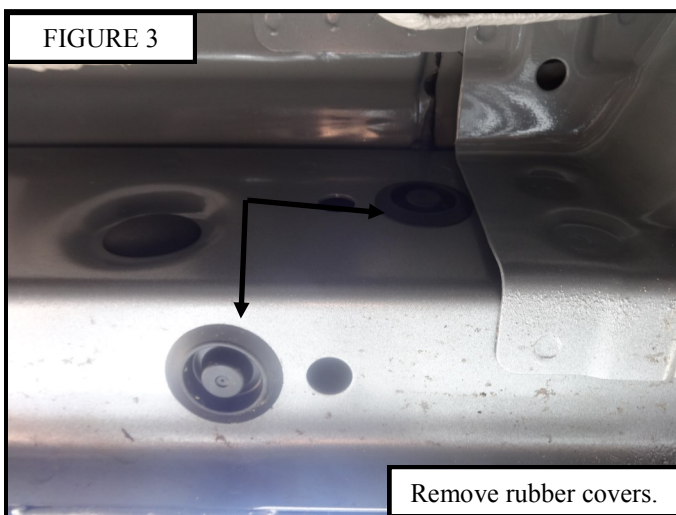
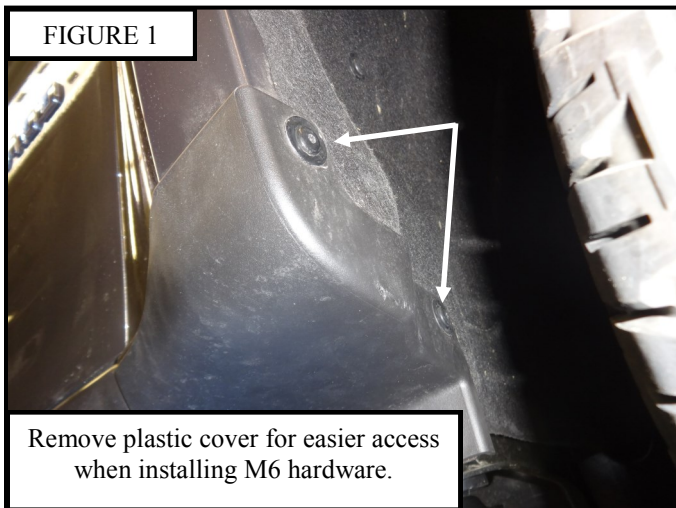

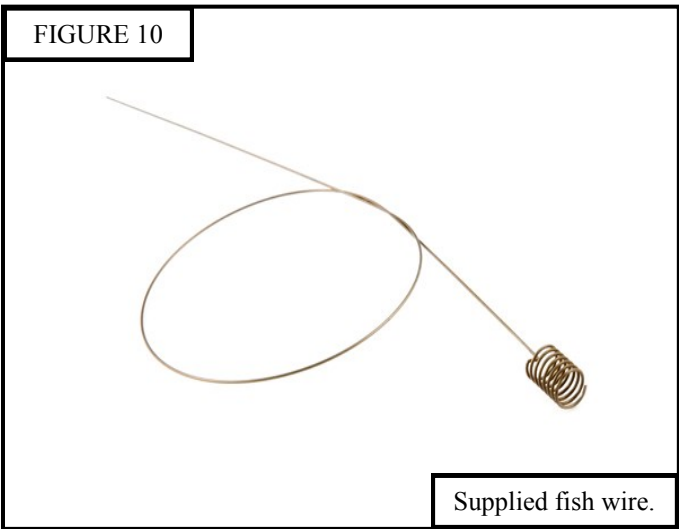
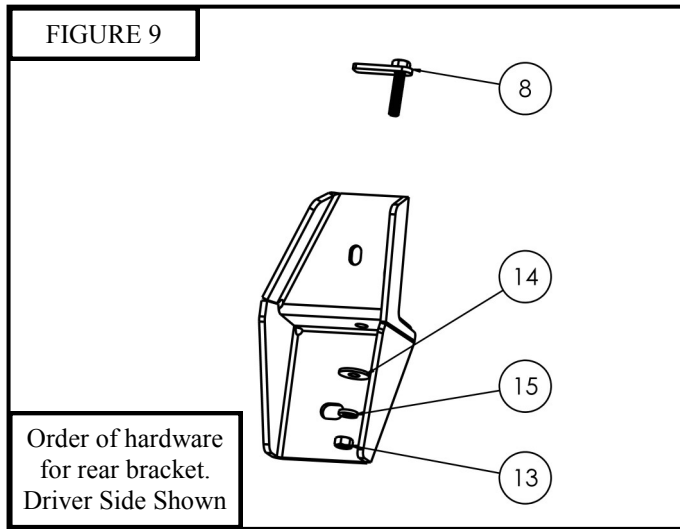
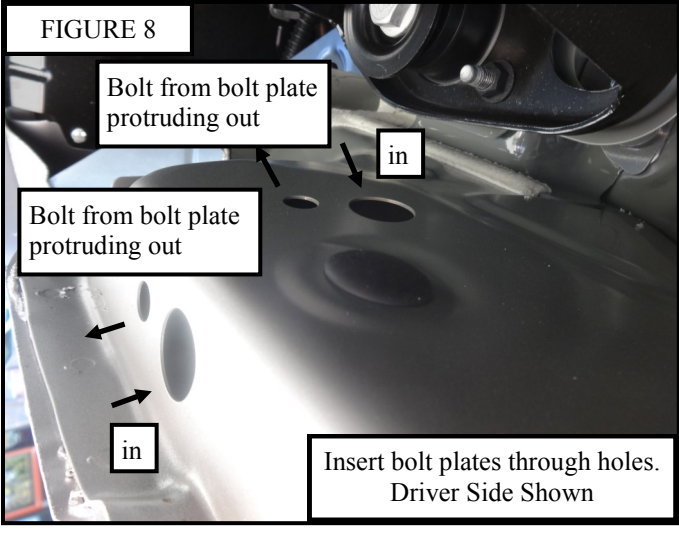
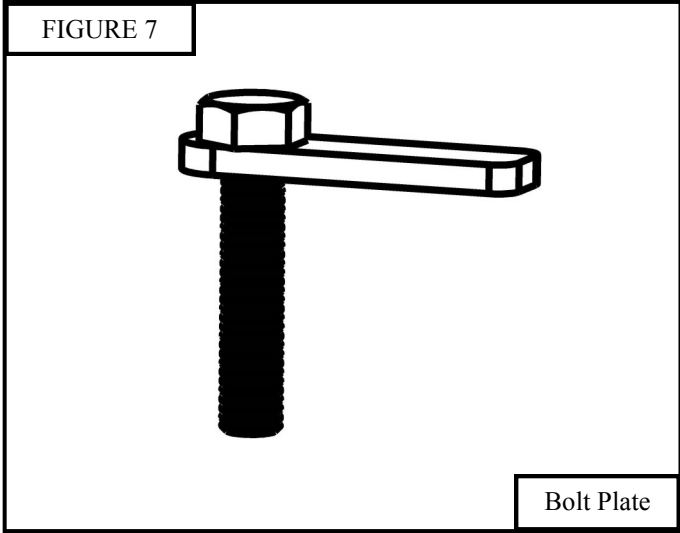
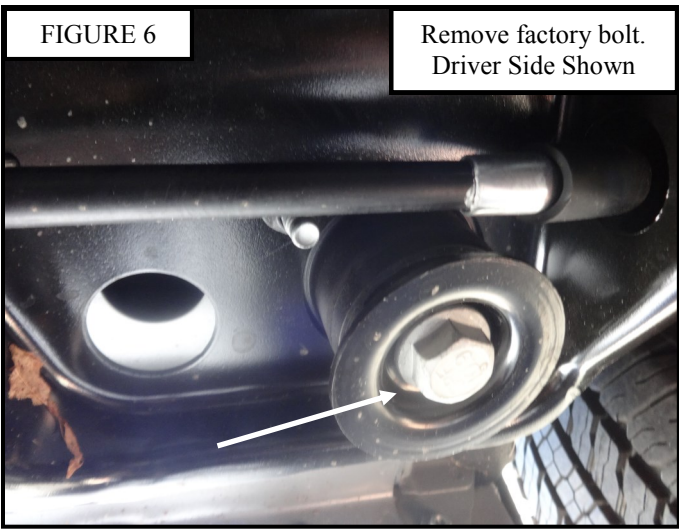
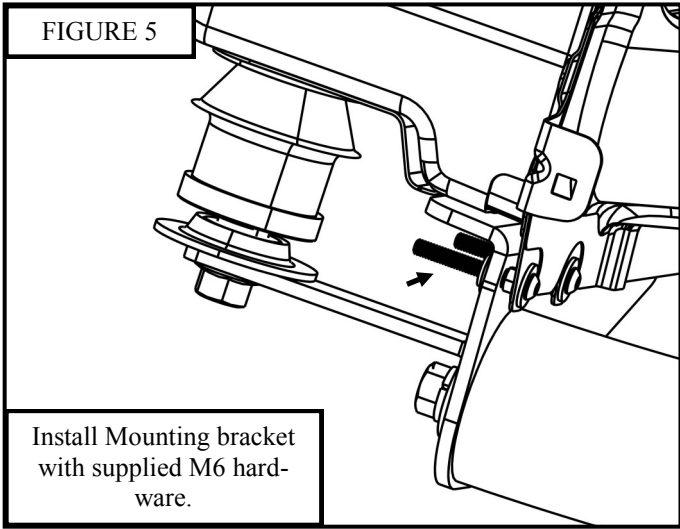

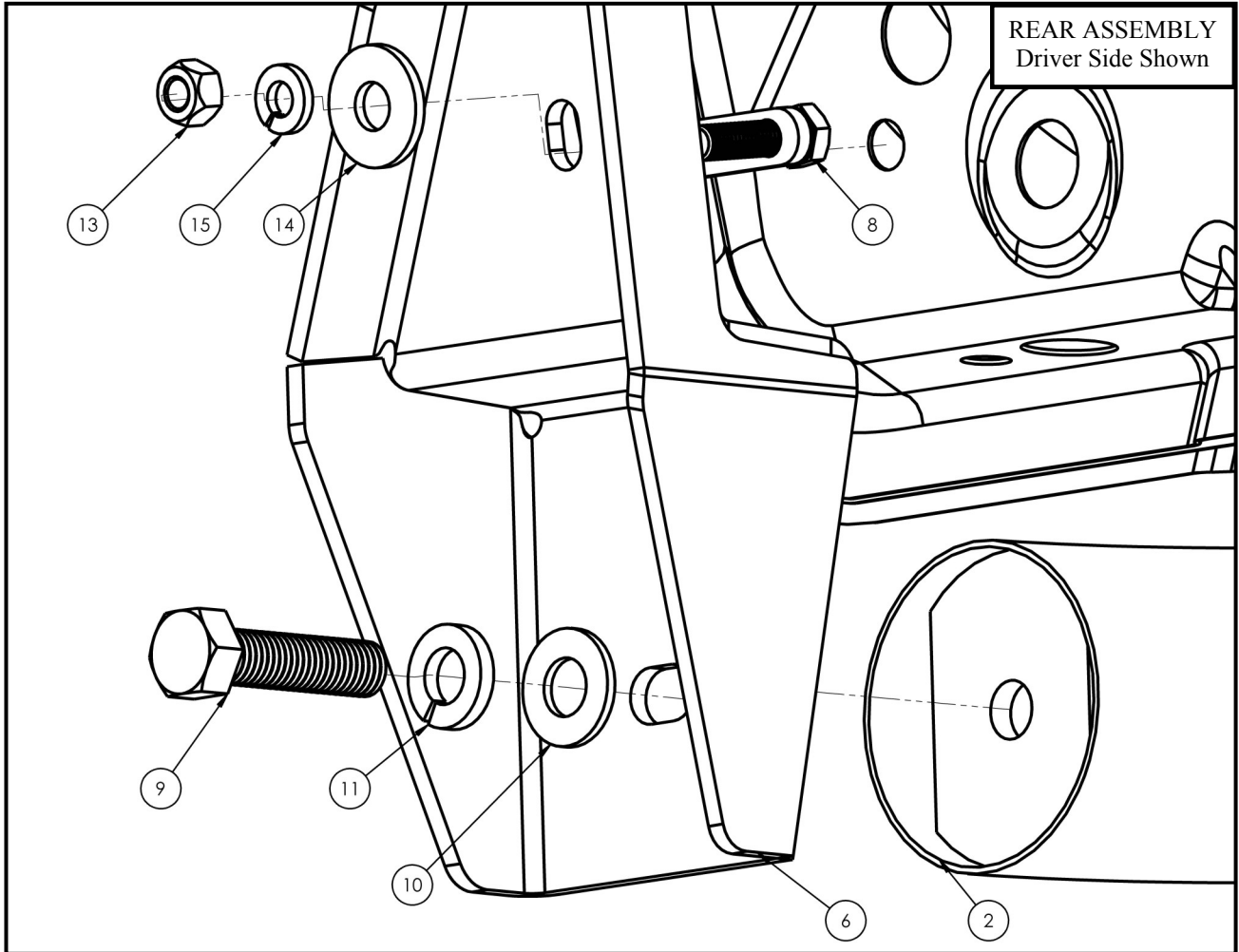
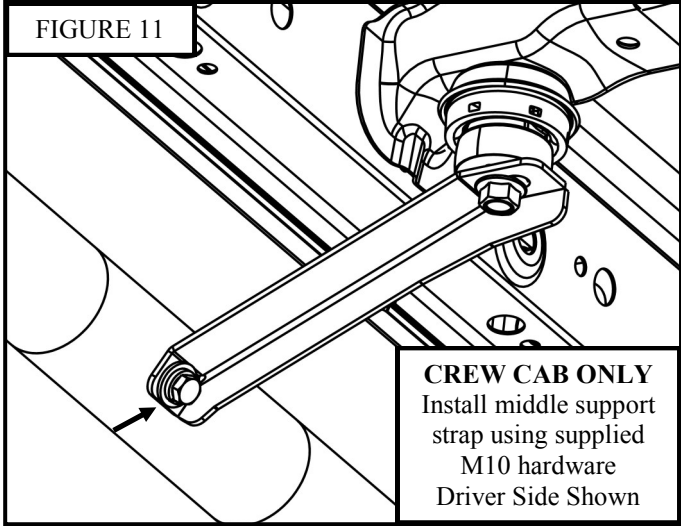

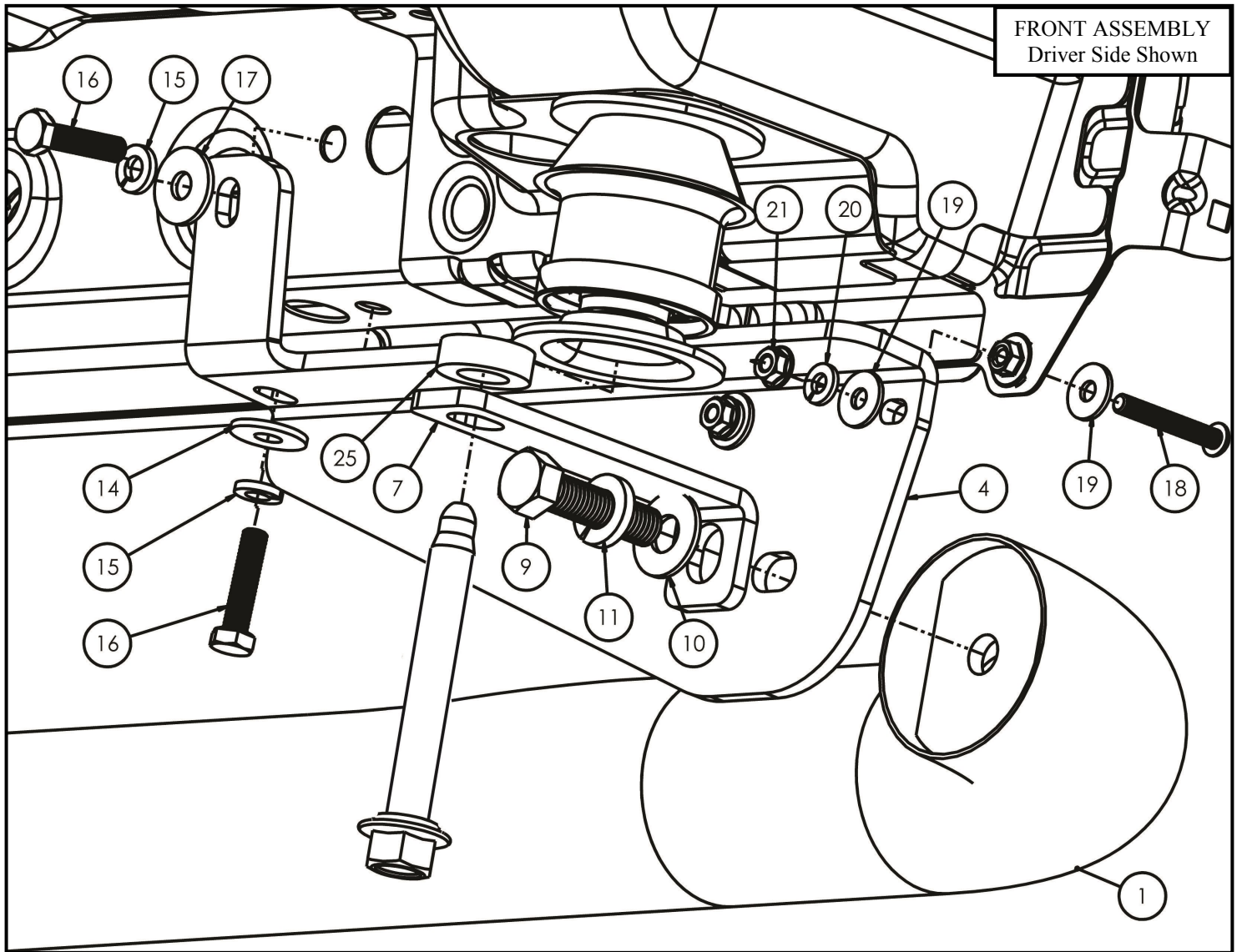

CARE INSTRUCTIONS

- REGULAR WAXING IS RECOMMENDED. DO NOT USE ANY TYPE OF POLISH OR WAX THAT MAY CONTAIN ABRASIVES.
- STAINLESS STEEL PRODUCTS CAN BE CLEANED WITH MILD SOAP AND WATER. STAINLESS STEEL POLISH SHOULD BE USED TO POLISH SMALL SCRATCHES.
- GLOSS BLACK FINISHES SHOULD BE CLEANED WITH MILD SOAP AND WATER.