



INSTALLATION INSTRUCTIONS

OUTLAW REAR BUMPER

APPLICATION: 2013-2018 Dodge Ram 1500

PART NUMBER: 58-81025

CONTENT			
ITEM	QUANTITY	DESCRIPTION	TOOLS NEEDED
1	1	REAR BUMPER	18MM WRENCH
2	4	SENSOR L-TAB	5MM ALLEN
3	1	TRAILER CONNECTOR BRACKET	13MM SOCKET
4	1	LICENSE PLATE SWING MOUNT	17MM SOCKET
5,6	2	FRAME BRACKET, DRIVER (5) AND PASSENGER (6)	19MM SOCKET
7	2	LED CUTOFF MESH COVER	13MM WRENCH
8	8	M14 FINE THREAD HEX HEAD BOLT (BLACK ZINC)	17MM WRENCH
9	8	M14 FLAT WASHER (BLACK ZINC)	19MM WRENCH
10	8	M14 SPLIT LOCK WASHER (BLACK ZINC)	10MM SOCKET
11	4	M12 HEX HEAD BOLT (BLACK ZINC)	10MM WRENCH
12	4	M12 HEX NUT (BLACK ZINC)	PLYER TOOL
13	8	M12 FLAT WASHER (BLACK ZINC)	RATCHET
14	4	M12 SPLIT LOCK WASHER (BLACK ZINC)	TORQUE WRENCH
15	4	M6 CARRIAGE BOLT (BLACK ZINC)	ELECTRICAL TAPE
16	4	M6 SPLIT LOCK WASHER (BLACK ZINC)	
17	4	M6 FLAT WASHER (BLACK ZINC)	
18	4	M6 HEX NUT (BLACK ZINC)	
19	2	M8 CARRIAGE BOLT (BLACK ZINC)	
20	2	M8 HEX NUT (BLACK ZINC)	
21	2	M8 FLAT WASHER (BLACK ZINC)	
22	2	M8 SPLIT LOCK WASHER (BLACK ZINC)	
23	10	ZIP TIE (PLASTIC)	
24	10	ZIP TIE ADHESIVE SQUARE MOUNT (PLASTIC)	
25	2	T-TAB CONNECTOR MALE (PLASTIC)	
26	2	T-TAB CONNECTOR FEMALE (PLASTIC)	
27	5	M6 SEMS BUTTON HEAD HARDWARE	

ANTI-SEIZE LUBRICANT MUST BE USED ON ALL STAINLESS STEEL FASTENERS TO PREVENT THREAD DAMAGE AND GALLING

CARE INSTRUCTIONS

- REGULAR WAXING IS RECOMMENDED. DO NOT USE ANY TYPE OF POLISH OR WAX THAT MAY CONTAIN ABRASIVES.
- STAINLESS STEEL PRODUCTS CAN BE CLEANED WITH MILD SOAP AND WATER. STAINLESS STEEL POLISH SHOULD BE USED TO POLISH SMALL SCRATCHES.
- GLOSS BLACK FINISHES SHOULD BE CLEANED WITH MILD SOAP AND WATER.



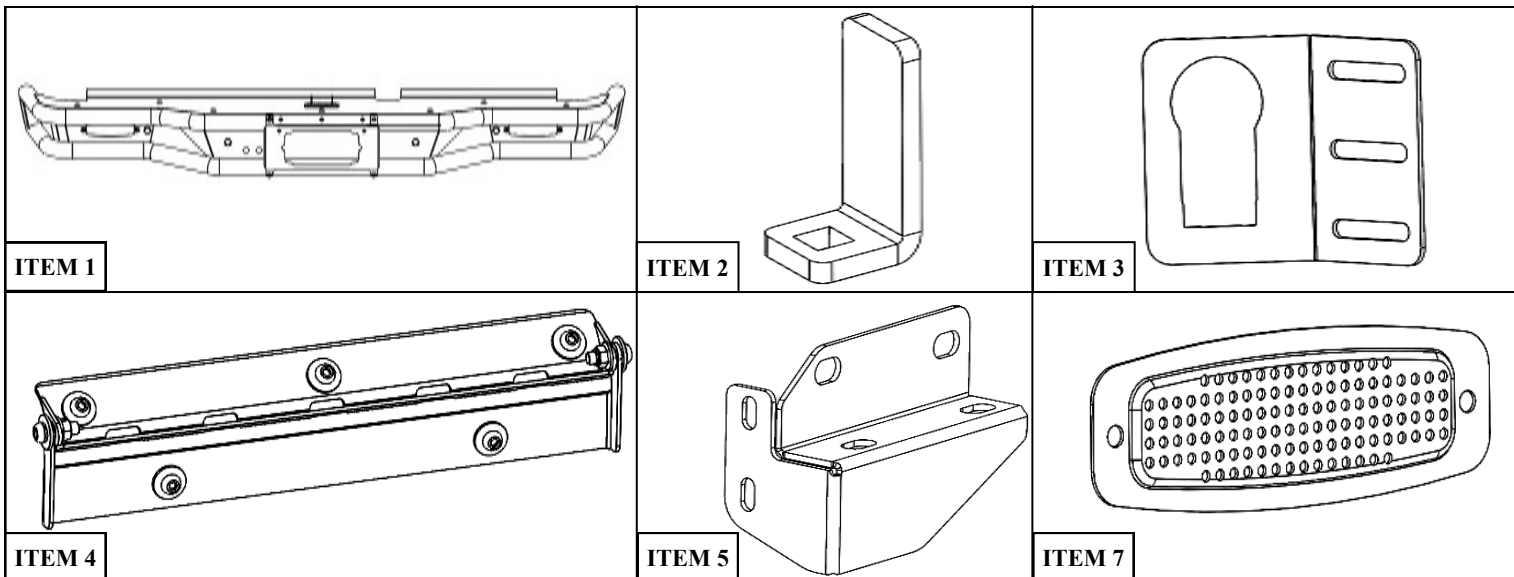

PROCEDURE

1. Remove contents from box, verify if all parts listed are present and free from damage.
Carefully read and understand all instructions before attempting installation.
Failure to identify damage before installation could lead to a rejection of any claim.
2. Disconnect license plate lights, trailer connector and park assist sensors so that bumper assembly can be removed.
3. Using a 21mm wrench remove the 8 bolts fastening the OEM hitch to the frame. (4 on each side) **See Figure 1.**

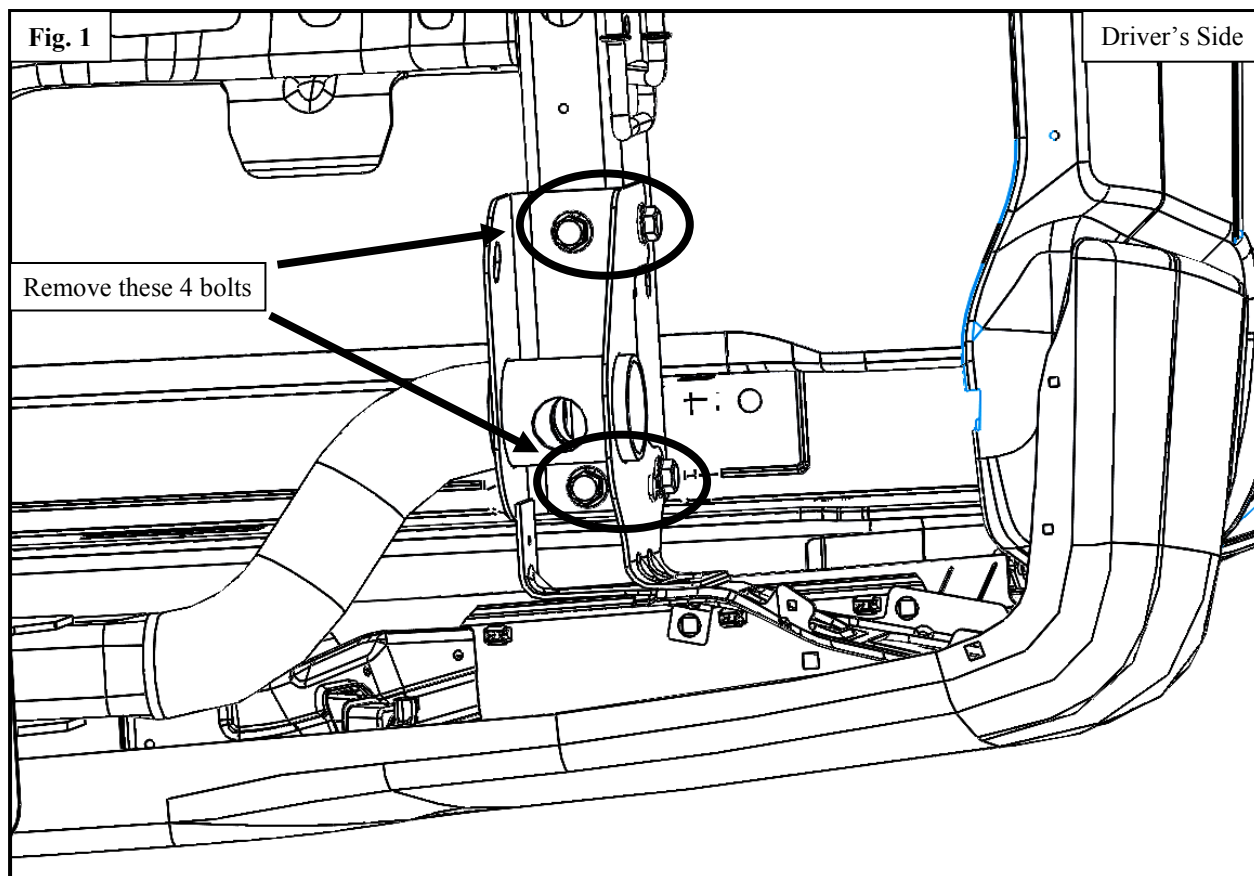

- Using the supplied M14 hardware (8-10), loosely install frame brackets (items 5 and 6) on frame. **Note:** Do not tighten hardware. Original hardware can be used instead of supplied hardware. See Figures 2 & 3.

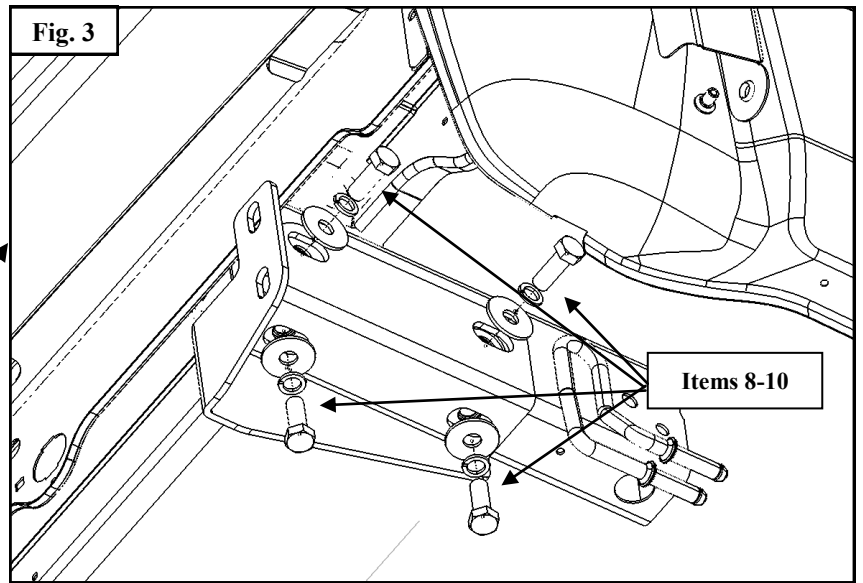
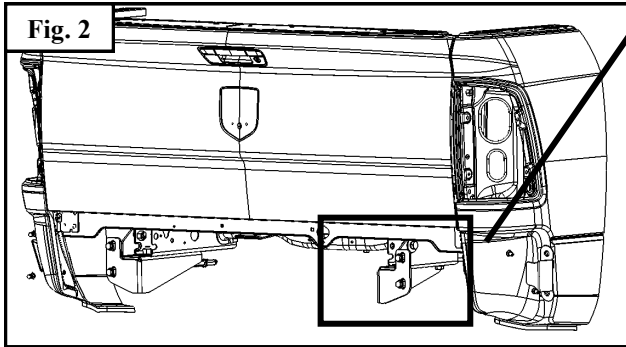

- Using the supplied M12 hardware (11-14), loosely install bumper (1) to frame brackets. See Figure 4.

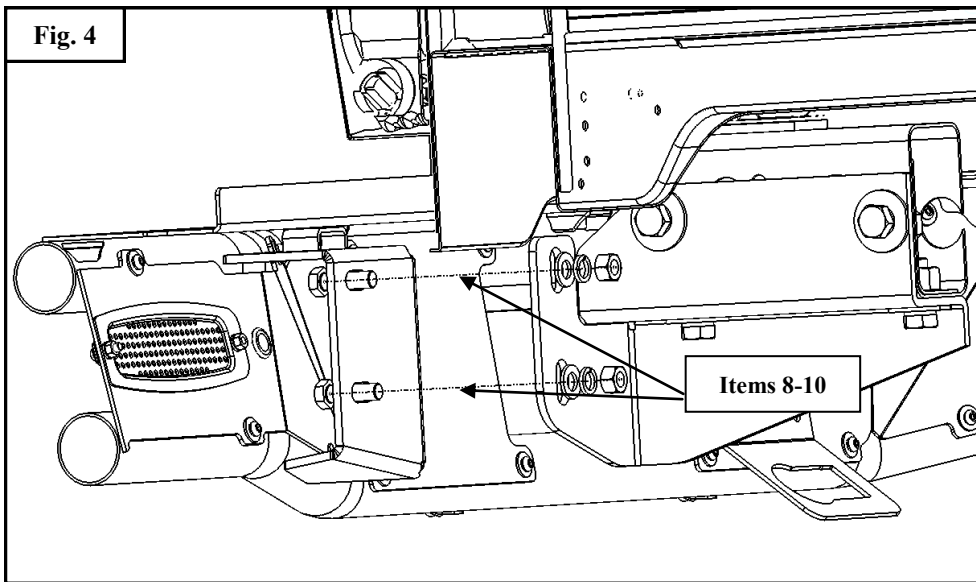

WARNING .
 After you have mounted bumper on main brackets. **CAREFULLY** open tailgate. While tailgate is open, adjust the height of the bumper so that it has about 3/8" of clearance with respect to the tailgate. Then tighten all M14 hardware to 75-80 ft-lbs and M12 hardware to 50-55 ft-lbs.

- Install parking sensors by positioning the holes concentrically on bumper and pressing with L-tabs (2) against bumper plate. Loosely fasten L-tabs with the supplied M6 hardware (15-18). See Figure 5.
- Use items 23 and 24 to secure sensor in place.
Note: Be sure to maintain the orientation of the sensor so that it remains consistent with its original orientation.
- Tighten M6 hardware to 5-7 ft-lbs.

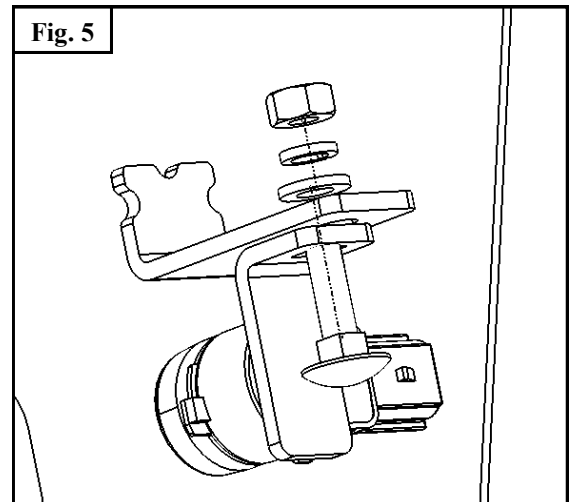

9. Using M8 hardware (19-22), install trailer connector bracket (3) to the back plate of the bumper. Adjust up and down as desired and tighten M8 hardware to 15-18 ft-lbs. See **Figure 6**.

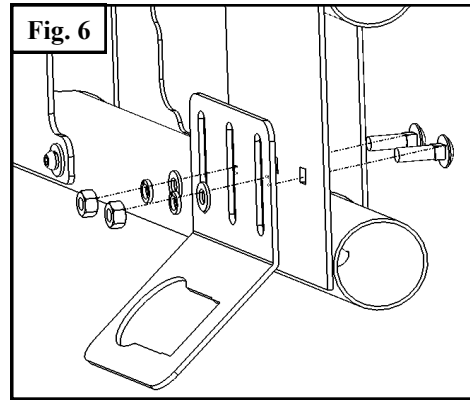

10. Using M6 SEMS button head hardware (27), install license plate swing mount (4) on bumper. Tighten M6 hardware to 5-7 ft-lbs. See **Figure 7**.
11. Install license plate on item 4 using M6 SEMS button head hardware (Item 27) and tighten to 5-7 ft-lbs.
12. Tighten the two nylon lock nuts on the sides until it has just enough resistance to prevent rotation due to normal condition while still allowing rotation by hand when desired or needed to access hitch.

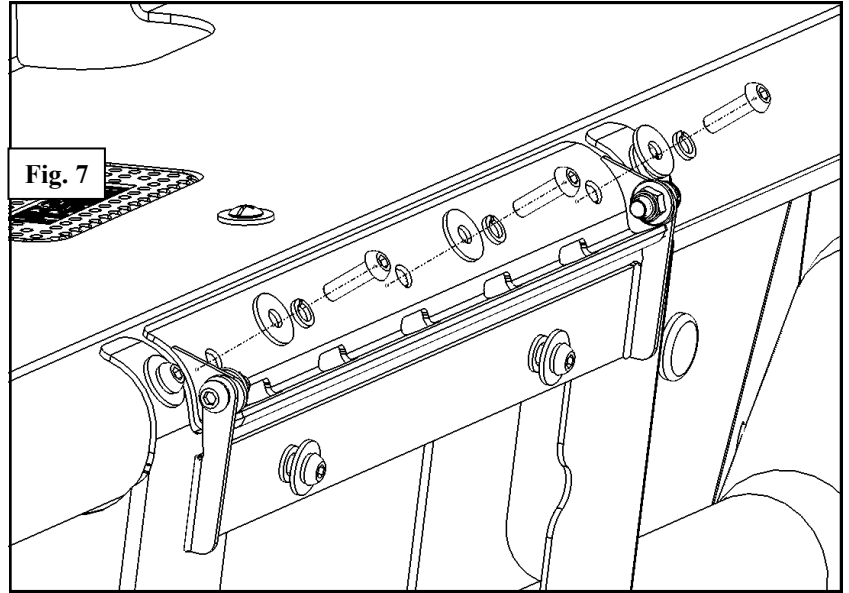

13. Using items 25 and 26 connect the LED license plate light to one of the OEM license plate lights. Connect the black cable from the LED tape to the black cable going into the OEM license plate light. Then, connect the red cable on the LED tape to the colored (non-black) cable going to the OEM license plate light. Crimp carefully and cover with electrical tape. Use supplied zip ties and zip tie mounts to position cables as desired.

INSTALLATION COMPLETE





WARNING



Failure to follow these instructions could lead to death, personal injury, and / or property damage.

FASTENERS:

All Westin supplied fasteners must be utilized and installed in accordance with the installation instructions and apply torque to the specifications as defined. **DOUBLE CHECK ALL FASTENERS BEFORE INITIAL USE, AND PERIODICALLY IN THE FUTURE TO ENSURE PROPER FUNCTION AND SAFETY.**

DRILLING:

Most Westin products do not require drilling for installation. If drilling is defined as required, use caution when drilling a vehicle. **FAILURE TO REVIEW AN AREA TO BE DRILLED MAY RESULT IN PERSONAL INJURY AND/OR INJURY TO OTHERS AS WELL AS VEHICLE DAMAGE.**

EYE PROTECTION:

ALWAYS WEAR SAFETY GLASSES OR GOGGLES DURING THE INSTALLATION PROCESS TO AVOID PERSONAL INJURY.

MAXIMUM TOWING/CARRYING CAPACITY:

The Westin Receiver Hitches will have a visible tow rating label affixed directly on the product. User should never exceed the vehicle manufacturers maximum tow and weight rating regardless of the capacity of the hitch. **FAILURE TO FOLLOW THESE GUIDELINES WILL VOID THE WESTIN WARRANTY AND MAY RESULT IN PERSONAL INJURY AND/OR INJURY TO OTHERS AS WELL AS VEHICLE DAMAGE.**

