

INSTALLATION INSTRUCTIONS



LOWER PILLAR MOUNT

APPLICATION:

2007-2018 Jeep Wrangler JK (Excl. JL)

PART NUMBER:

62-41045

ITEM	QUANTITY	DESCRIPTION	TOOLS NEEDED
1,2	2	MOUNT BRACKET, DRIVER (1) AND PASSENGER (2)	T-40 TORX SOCKET
3	4	M8 SPLIT LOCK WASHER (RAW)	RATCHET
4	2	LONG M8 SOCKET HEAD CAP SCREW (RAW)	TORQUE WRENCH
5	2	SHORT M8 SOCKET HEAD CAP SCREW (RAW)	
6	2	M10 SERRATED FLANGE NUT (YELLOW ZINC)	
7	1	FOAM TAPE	

ANTI-SEIZE LUBRICANT MUST BE USED ON ALL STAINLESS STEEL FASTENERS TO PREVENT THREAD DAMAGE AND GALLING

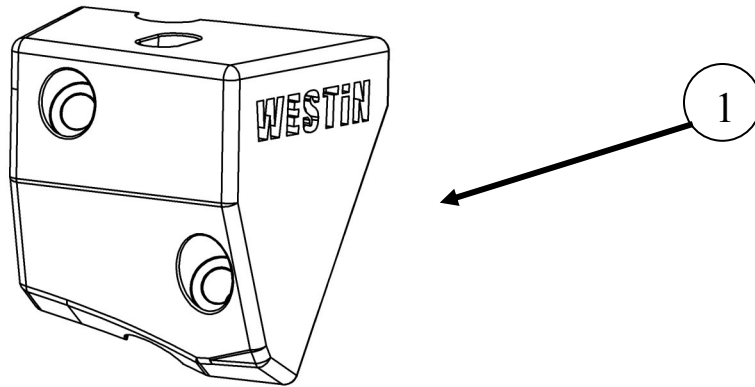

PROCEDURE

1. Remove contents from box, verify if all parts listed are present and free from damage.
Carefully read and understand all instructions before attempting installation.
Failure to identify damage before installation could lead to a rejection of any claim.



- Starting on the driver side of the vehicle, locate and remove the two bolts located on the lower A-pillar using a T-40 torx driver. Refer to **Figure 1**.
- Locate the supplied foam tape and trim enough to cover the backside of the mount bracket (Items 1 and 2). Place the trimmed tape on the bracket's mounting surface. Refer to **Figure 2**.

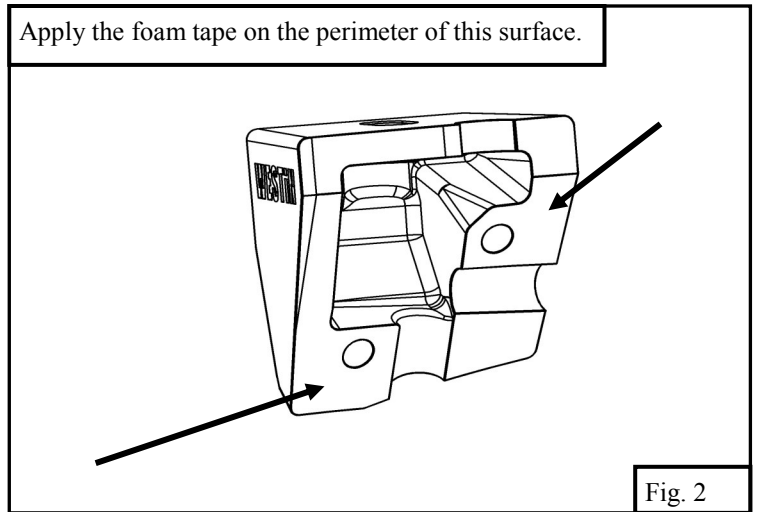

- Note:** Lights sold separately. Before installing the bracket on the A-pillar, mount the light onto the bracket as shown in **Figure 3** and secure it using the provided M10 flange nut (6) and/or the hardware supplied with the light. Route the light wiring through the grooves located on the back side of mounting bracket. Refer to **Figure 4**.

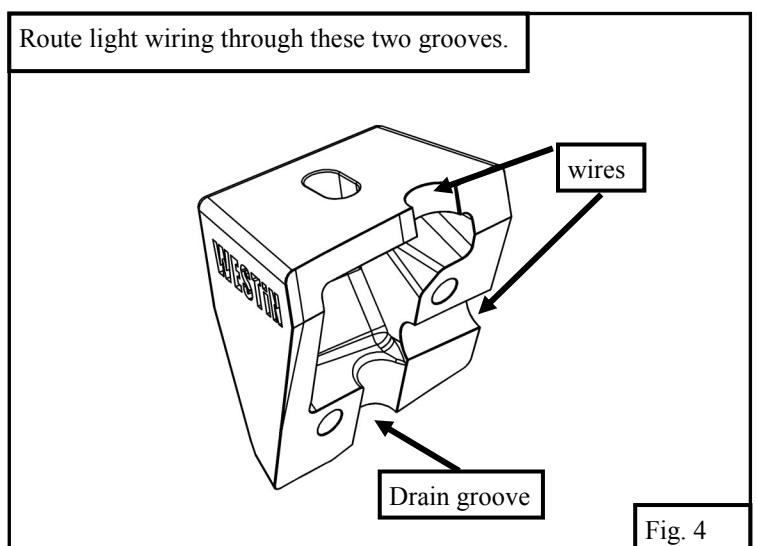
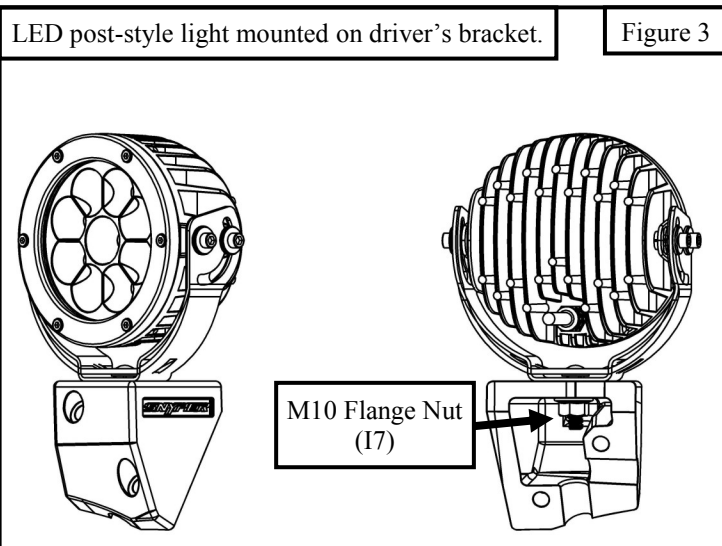

- Position the driver mounting bracket up against the A-pillar and align the two holes of the bracket with those of the vehicle. Secure the upper hole using one long M8 socket head cap screw (4) and one M8 split lock washer (3). For the lower hole, secure the bracket using one short M8 socket head cap screw (5) and one M8 split lock washer (3). Refer to **Figure 5** for a picture showing the complete assembly of the lower pillar light mount.
- Repeat steps 2-5 for passenger side.
- Torque all M8 fasteners to 15-18 ft-lbs.

Figure 5

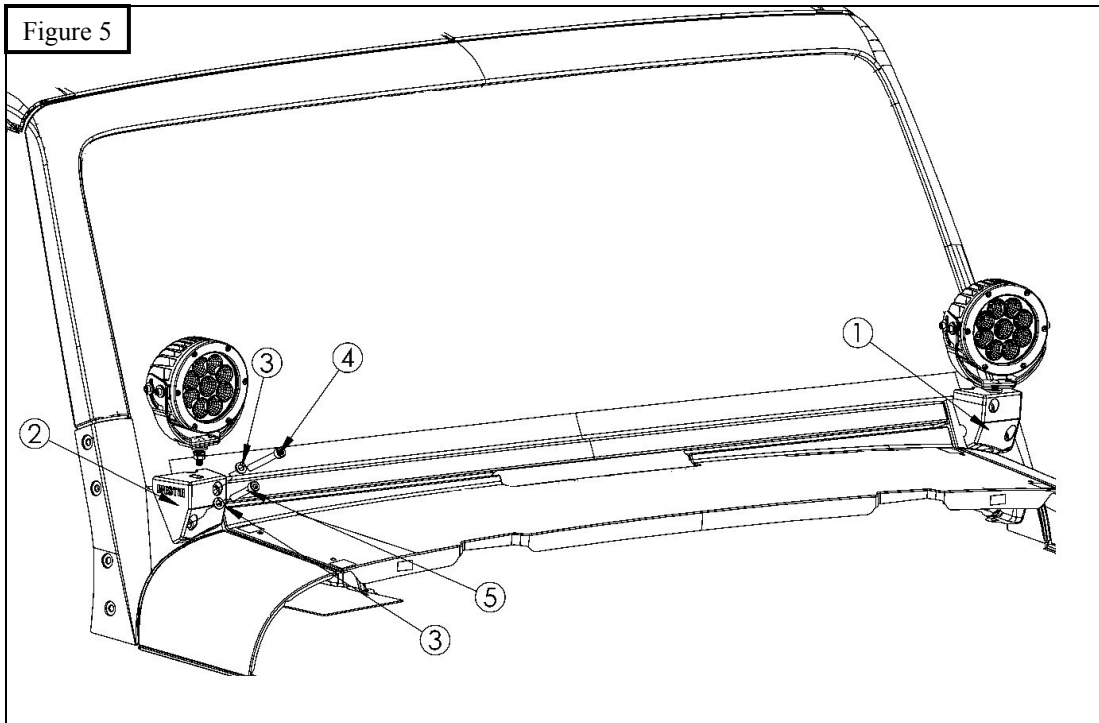

INSTALLATION COMPLETE



HD LED LIGHT COWL MOUNT SOLD SEPARATELY

CARE INSTRUCTIONS

- REGULAR WAXING IS RECOMMENDED. DO NOT USE ANY TYPE OF POLISH OR WAX THAT MAY CONTAIN ABRASIVES.
- STAINLESS STEEL PRODUCTS CAN BE CLEANED WITH MILD SOAP AND WATER. STAINLESS STEEL POLISH SHOULD BE USED TO POLISH SMALL SCRATCHES.
- GLOSS BLACK FINISHES SHOULD BE CLEANED WITH MILD SOAP AND WATER.

WESTIN