

INSTALLATION INSTRUCTIONS

REAR INNER FENDERS



APPLICATION:
2018-2019 Jeep Wrangler JL
PART NUMBER:
62-11035

CONTENT			
ITEM	QUANTITY	DESCRIPTION	TOOLS NEEDED
1	1	DRIVER REAR INNER FENDER	10MM SOCKET
2	1	PASSENGER REAR INNER FENDER	10MM WRENCH
3	1	DRIVER FRONT BRACKET	PRY TOOL
4	1	PASSENGER FRONT BRACKET	ALLEN WRENCH
5	1	DRIVER REAR BRACKET	RATCHET
6	1	PASSENGER REAR BRACKET	TORQUE WRENCH
7	1	DRIVER UPPER BRACKET	
8	1	PASSENGER UPPER BRACKET	
9	8	M6 BUTTON HEAD SCREW (BLACK ZINC)	
10	3	M6 HEX HEAD CAP SCREW (BLACK ZINC)	
11	10	M6 FLAT WASHER (BLACK ZINC)	
12	10	M6 SPLIT LOCK WASHER (BLACK ZINC)	
13	4	M6 HEX NUT (YELLOW ZINC)	
14	2	M6 SERRATED FLANGE NUT (YELLOW ZINC)	
15	3	M6 HEX HEAD CAP SCREW (YELLOW ZINC)	
16	8	M6 FLAT WASHER (YELLOW ZINC)	
17	6	M6 SPLIT LOCK WASHER (YELLOW ZINC)	
18	10	M6 U-CLIP	

ANTI-SEIZE LUBRICANT MUST BE USED ON ALL STAINLESS STEEL FASTENERS TO PREVENT THREAD DAMAGE AND GALLING



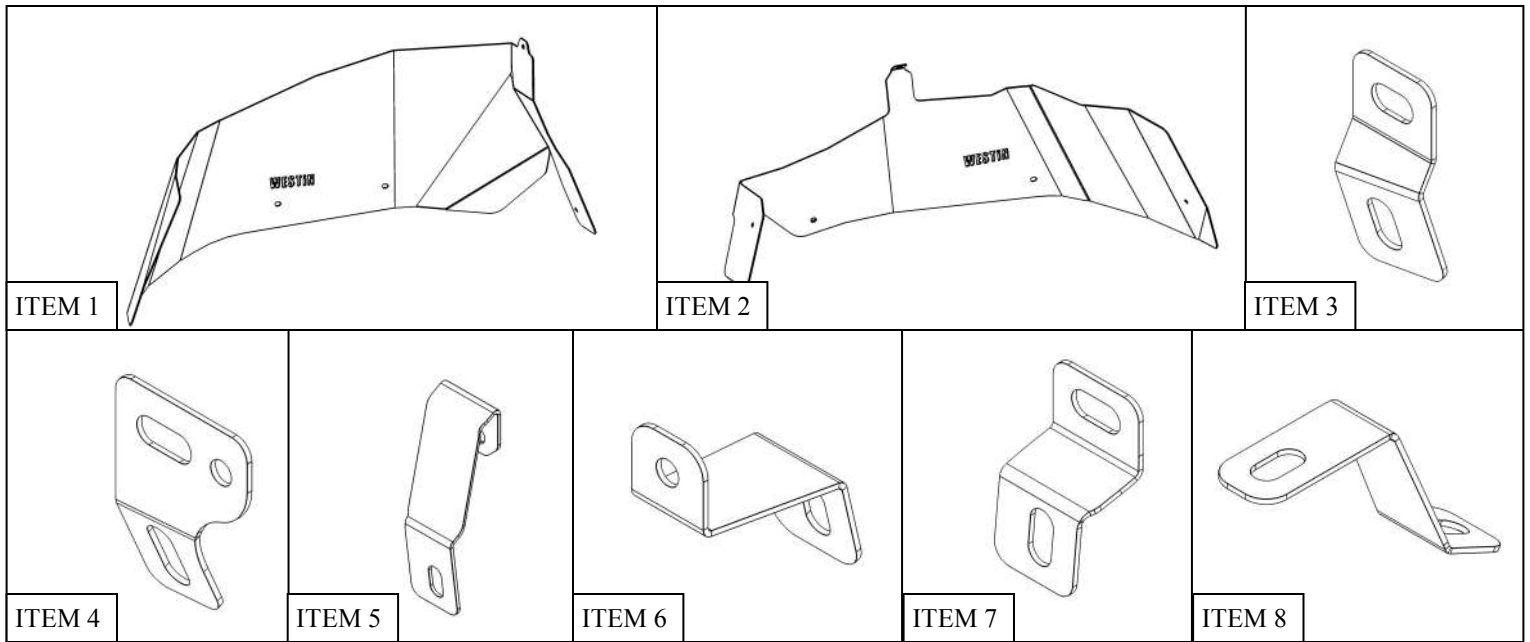

WARNING

Part # 62-11035 is designed to specifically fit with Westin Tube Fenders (Part # 62-1035). Modification may be required for other aftermarket fenders

PROCEDURE

- Remove contents from box, verify if all parts listed are present and free from damage. Carefully read and understand all instructions before attempting installation.
Failure to identify damage before installation could lead to a rejection of any claim.
- Beginning on the driver's side, secure the Driver Front Bracket (3) to the bottom side of the fender well **just tight enough to still allow movement** using the supplied M6 Hardware. Also, install U-Clips (18) to the bracket as well as to the adjacent tab on the fender well. See **Figure 1**.
Note 1: OEM Inner Fender must be removed prior to Driver Side install.
Note 2: If necessary, bend the fender well tabs forwards to install U-Clips.

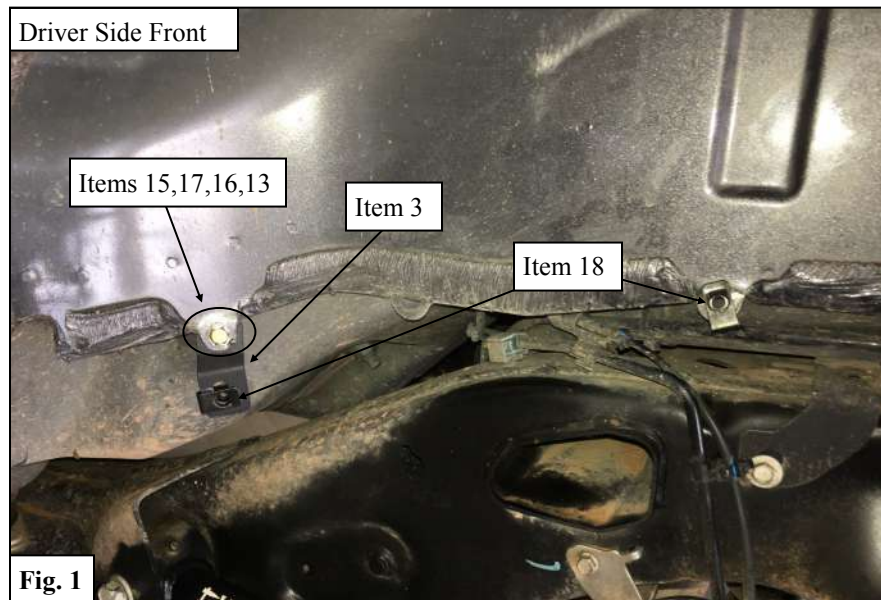

3. Install another U-Clip (18) onto the tab next to the tab shown in **Figure 1**. See **Figure 2**.
4. Use the supplied M6 Hardware to install the Driver Upper Bracket (7) inside the fender well just above the shock. See **Figure 3**. **Note:** *Install bracket just tight enough to still allow movement.*

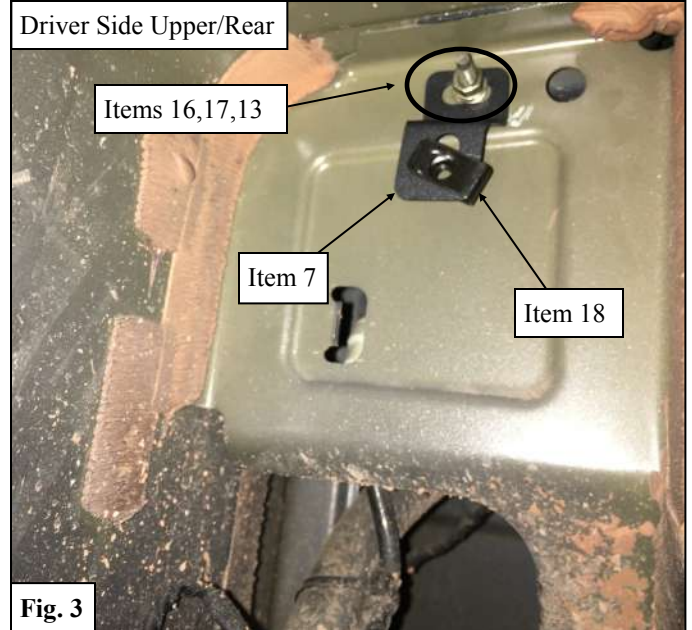
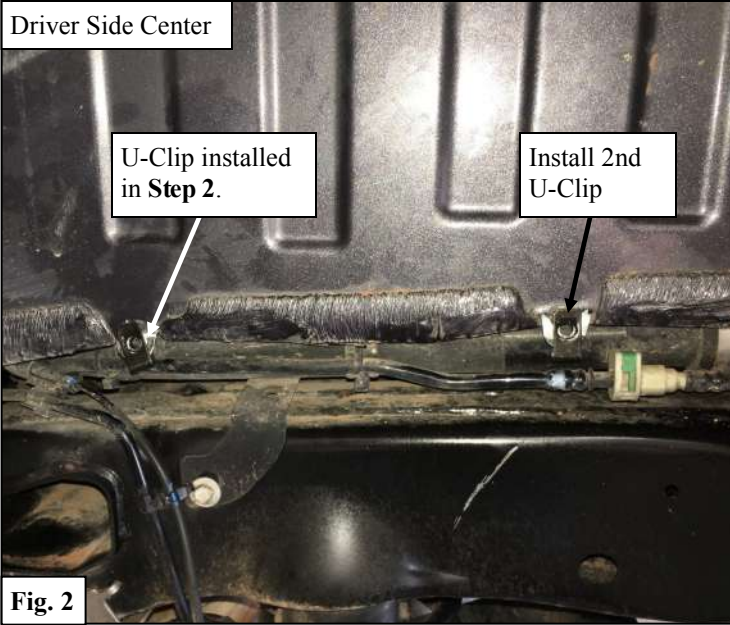

5. Install the Driver Rear Bracket (5) just behind the shock using the supplied M6 Hardware. See **Figure 4**. **Note:** *Install bracket just tight enough to still allow movement.*
6. Loosely install the Driver Rear Inner Fender (1). **Note:** *The tire may be removed from the vehicle to aid installation.*
7. Adjust brackets as needed and tighten all reachable bracket mounting hardware to 8 ft-lbs.
8. Remove the Inner Fender.
9. Tighten all remaining bracket mounting hardware.
10. Use the black M6 Hardware to loosely secure the Driver Inner Fender (1) to the previously installed brackets and U-Clips. See **Figures 5 & 12** for hardware attachment reference.

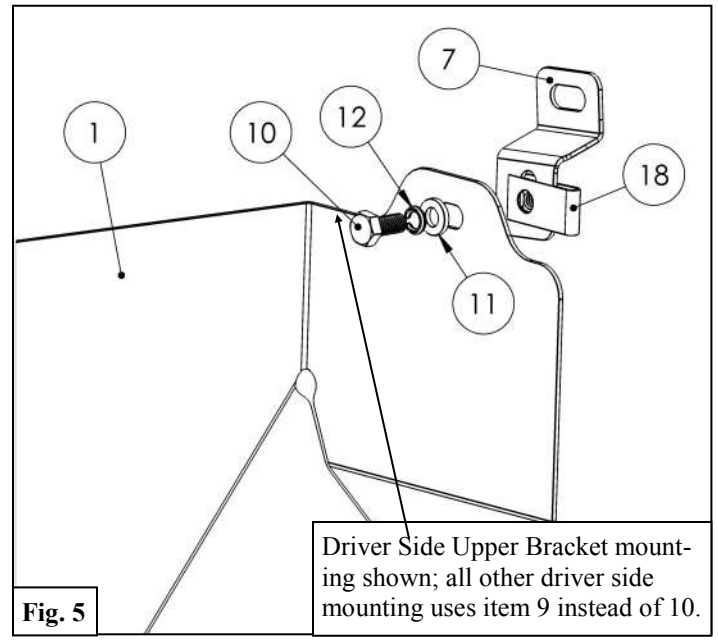
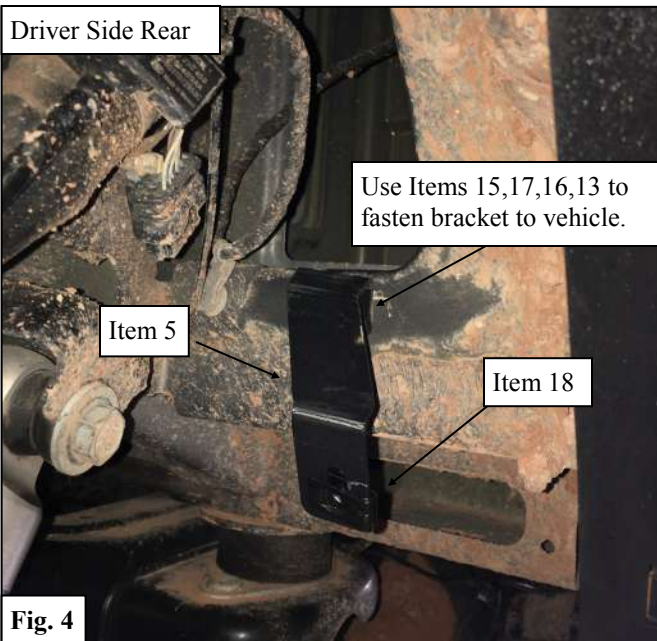

EXPLODED VIEW WITH BRACKETS FOR REFERENCE

Driver Side Only

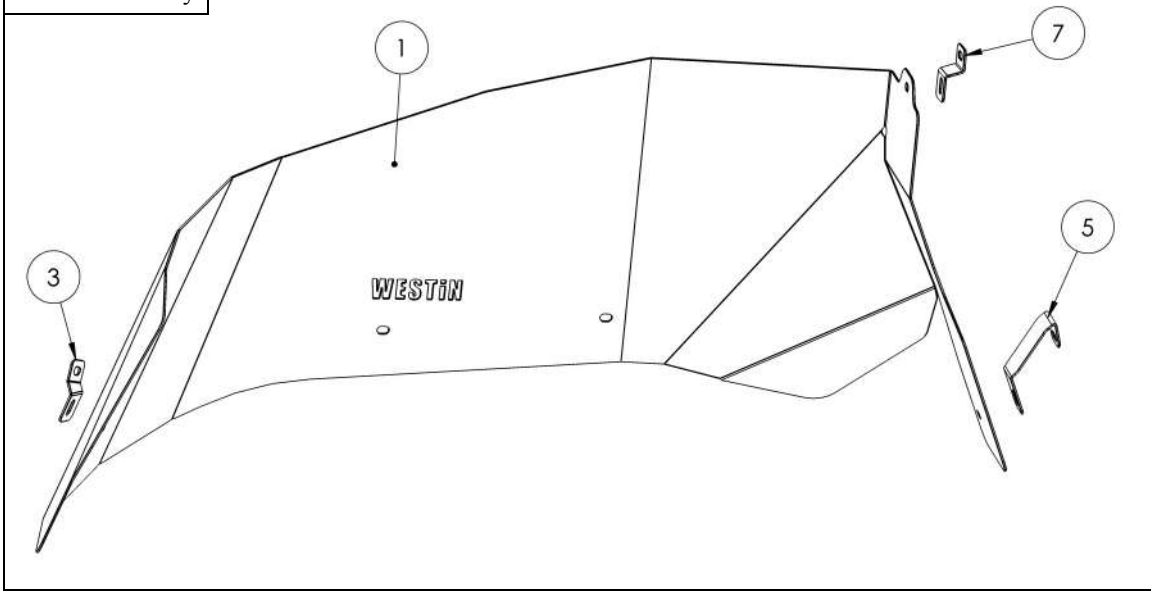

11. Move to the passenger side of the vehicle and temporarily remove the OEM Inner Fender.

Note: Passenger side OEM Inner Fender will be used in this installation.

12. Install the Passenger Front Bracket (4) to the inside of the fender well towards the front using the supplied M6 Hardware. See **Figure 6**.

Note: Install bracket just tight enough to still allow movement.

13. Attach two U-Clips (18) to the metal tabs on the middle of the fender well. See **Figures 7 & 8**.

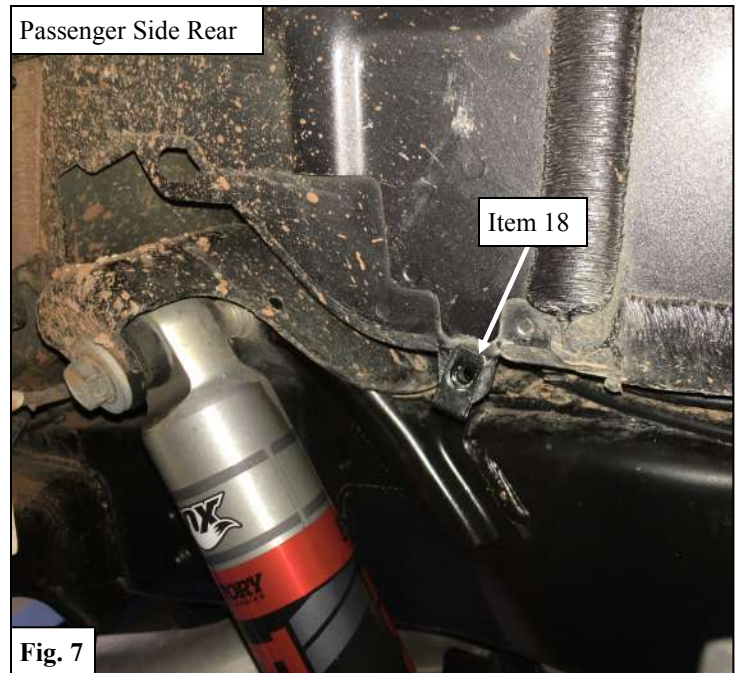
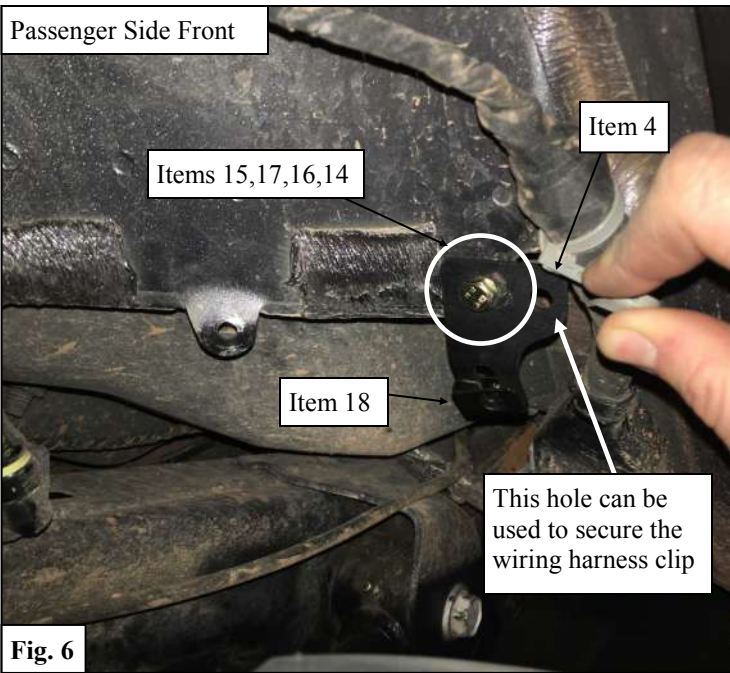

14. Use the supplied M6 Hardware to secure the Passenger Upper Bracket (8) to the bracket that secures the evap hoses. See **Figure 9**.

Note 1: Install bracket just tight enough to still allow movement.

Note 2: The Passenger Upper Bracket should be positioned on top of the OEM evap hose bracket.

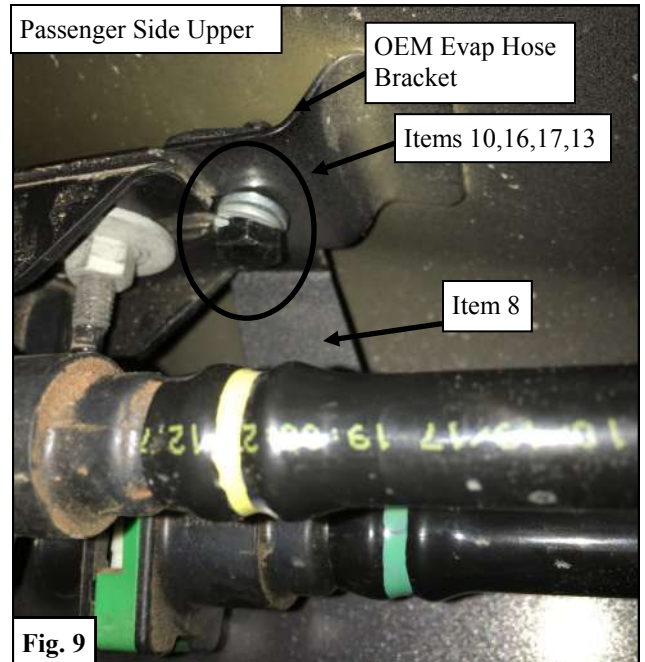
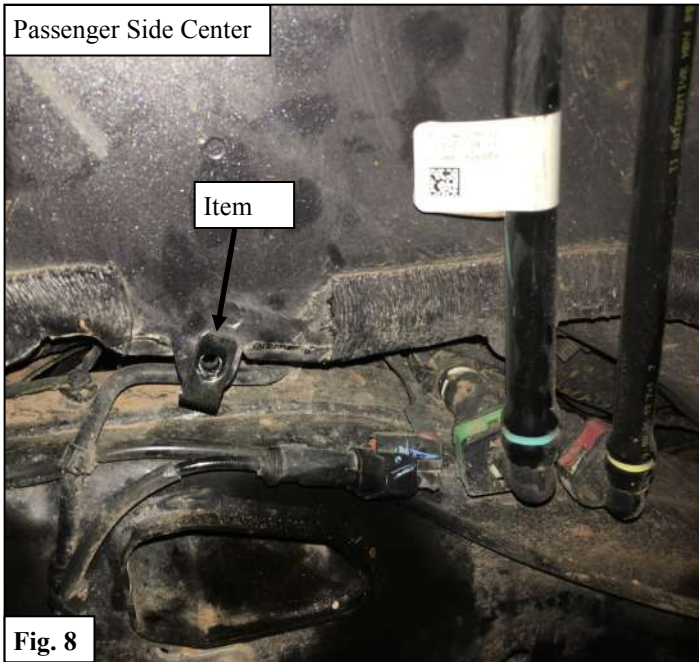

15. Install the Passenger Rear Bracket (6) onto the factory stud just behind the top rear shock mount using the supplied M6 Hardware. See **Figure 10**.

Note: Install bracket just tight enough to still allow movement.

16. Loosely install the Passenger Rear Inner Fender (2). See **Figures 11 & 12**.

Note1: The tire may need to be removed from the vehicle to aid installation.

Note2: Figure 11 is for the Passenger Upper Bracket only. All other locations to fasten the Inner Fender will use the hardware shown in Figure 12.

17. Adjust brackets as needed and tighten all reachable bracket mounting hardware to 8 ft-lbs.

18. Remove the Inner Fender.

19. Tighten all remaining bracket mounting hardware.



20. Use the black M6 Hardware to loosely secure the Passenger Rear Inner Fender (2) to the previously installed brackets and U-Clips. See **Figures 11 & 12** for hardware attachment reference. **Note: Figure 11 is for the Passenger Upper Bracket only.** All other locations to fasten the Inner Fender will use the hardware shown in **Figure 12**.

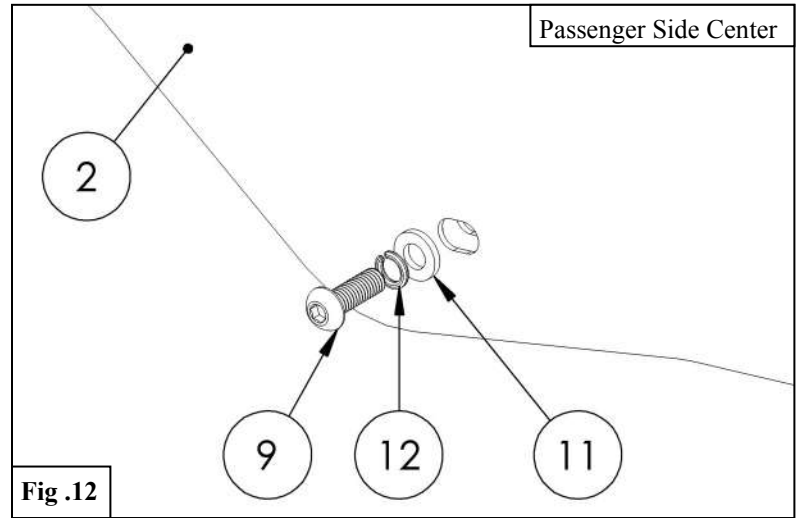
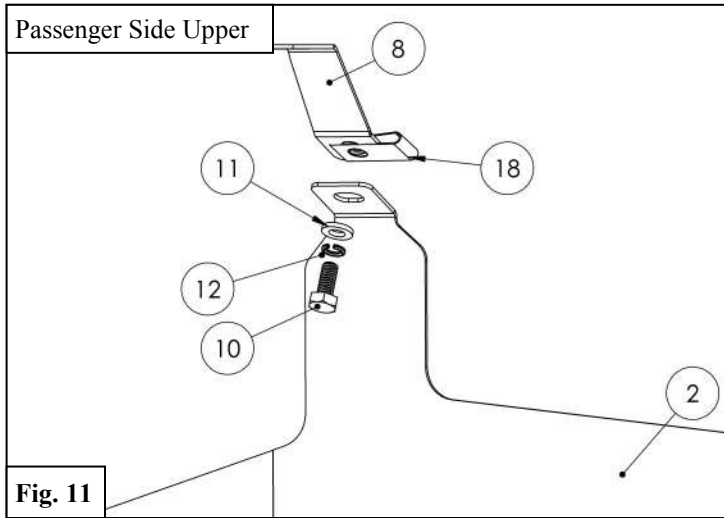

EXPLODED VIEW WITH BRACKETS FOR REFERENCE

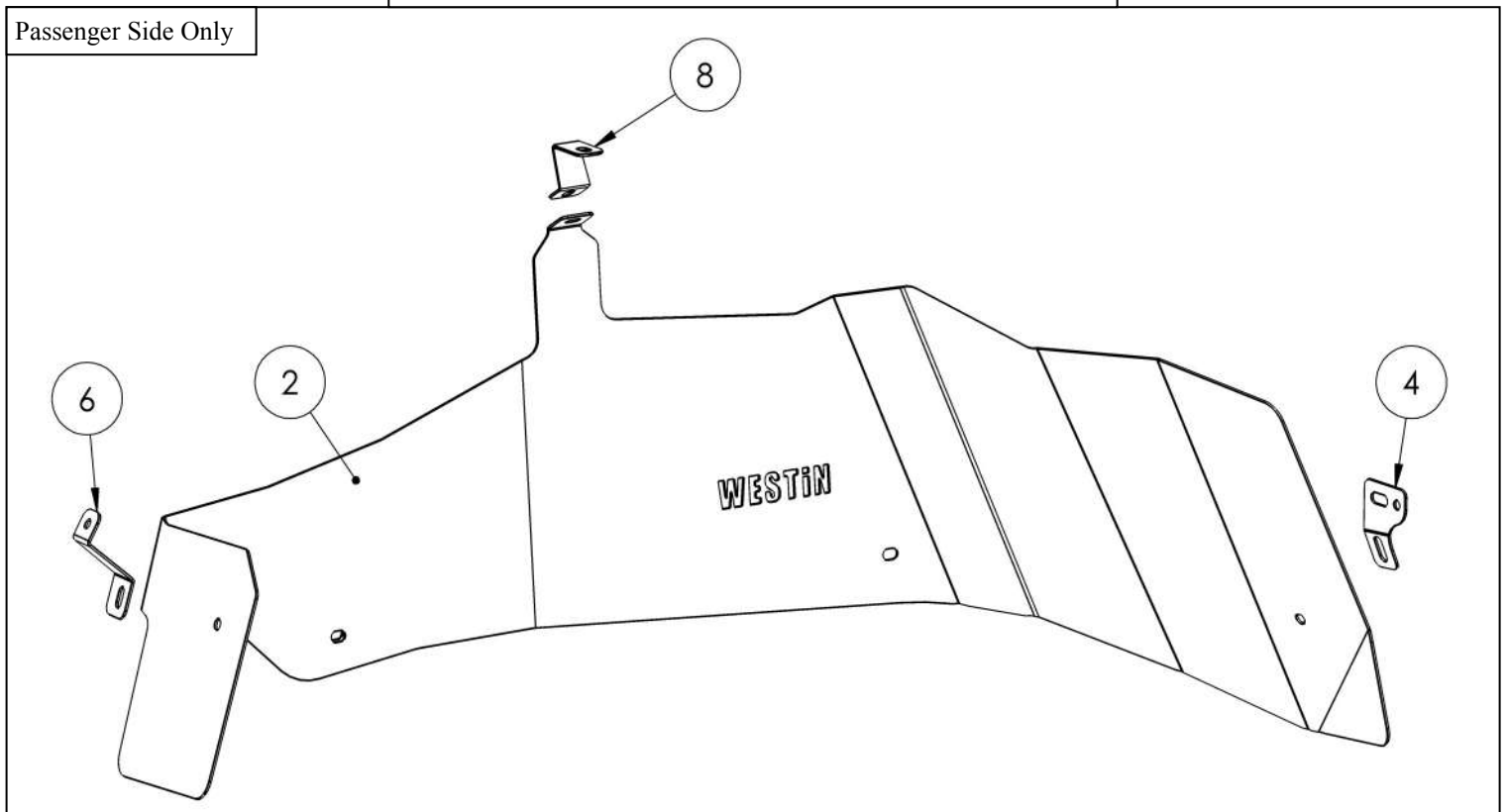

21. Trim and reinstall the passenger side OEM Inner Fender. If installed with Westin Tube Fenders (P# 62-1035), the upper edge of the OEM Inner Fender will fit over the lip of the tube fender. See **Figure 13**.

Note 1: Make sure to trim as little material from the OEM Inner Fender at this time.

Note 2: If installed with Westin Tube Fenders, rotate the fender liner as needed to fit the Westin Rear Inner Fender.

22. Mark the OEM Inner Fender and continue trimming until the bottom edge of the OEM Inner Fender rests between the Westin Rear Inner Fender and the back of the fender well. See **Figures 14, 15, & 16**.

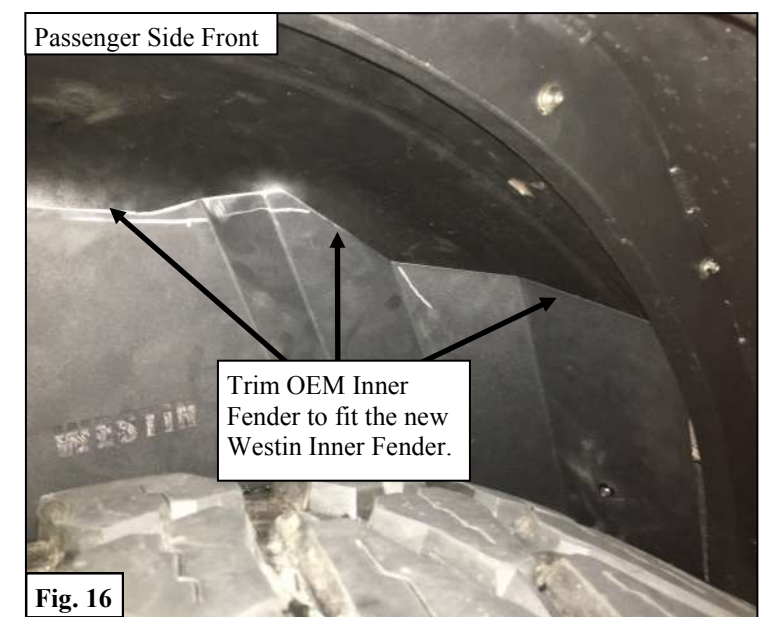
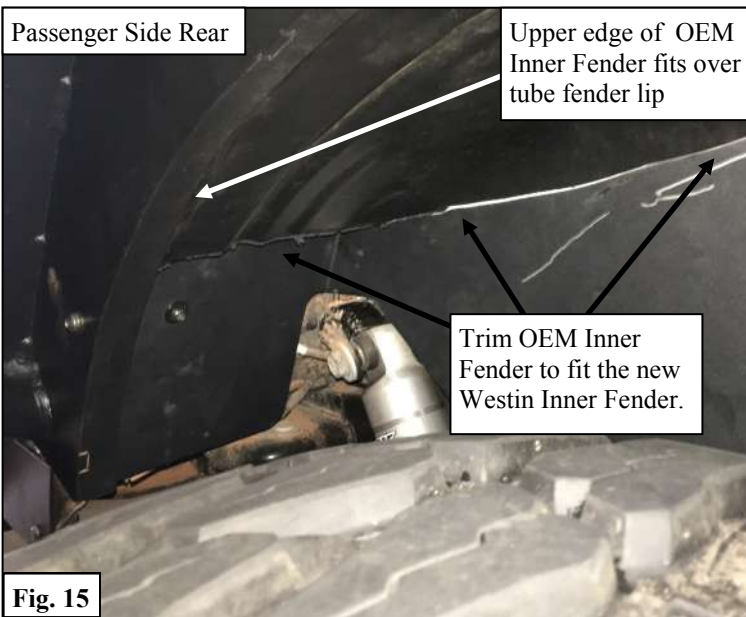
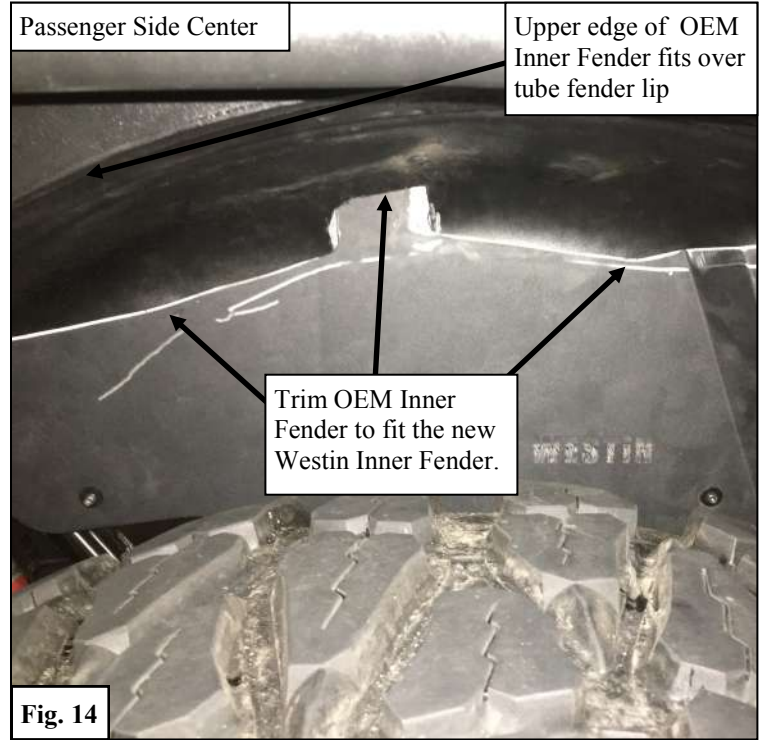
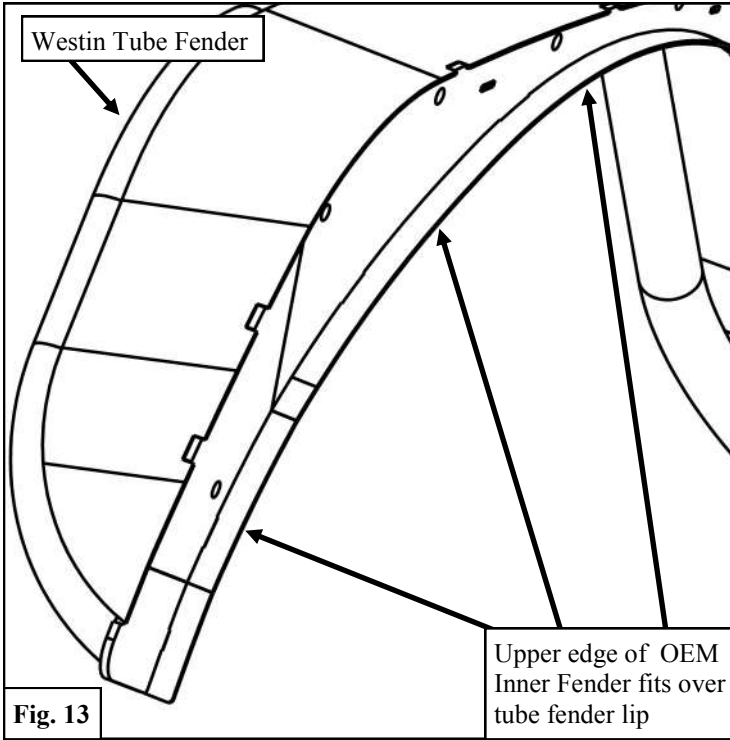

INSTALLATION COMPLETE



Tube Fenders Sold Separately

CARE INSTRUCTIONS

- REGULAR WAXING IS RECOMMENDED. DO NOT USE ANY TYPE OF POLISH OR WAX THAT MAY CONTAIN ABRASIVES.
- STAINLESS STEEL PRODUCTS CAN BE CLEANED WITH MILD SOAP AND WATER. STAINLESS STEEL POLISH SHOULD BE USED TO POLISH SMALL SCRATCHES.
- GLOSS BLACK FINISHES SHOULD BE CLEANED WITH MILD SOAP AND WATER

WESTIN



WARNING



Failure to follow these instructions could lead to death, personal injury, and / or property damage.

Failure to follow these instructions could lead to death, personal injury, and / or property damage.

FASTENERS:

All Westin supplied fasteners must be utilized and installed in accordance with the installation instructions and apply torque to the specifications as defined. **DOUBLE CHECK ALL FASTENERS BEFORE INITIAL USE, AND PERIODICALLY IN THE FUTURE TO ENSURE PROPER FUNCTION AND SAFETY.**

DRILLING:

Most Westin products do not require drilling for installation. If drilling is defined as required, use caution when drilling a vehicle. **FAILURE TO REVIEW AN AREA TO BE DRILLED MAY RESULT IN PERSONAL INJURY AND/OR INJURY TO OTHERS AS WELL AS VEHICLE DAMAGE.**

EYE PROTECTION:

ALWAYS WEAR SAFETY GLASSES OR GOGGLES DURING THE INSTALLATION PROCESS TO AVOID PERSONAL INJURY.

MAXIMUM TOWING/CARRYING CAPACITY: (if applicable)

The Westin Receiver Hitches will have a visible tow rating label affixed directly on the product. User should never exceed the vehicle manufacturers maximum tow and weight rating regardless of the capacity of the hitch. **FAILURE TO FOLLOW THESE GUIDELINES WILL VOID THE WESTIN WARRANTY AND MAY RESULT IN PERSONAL INJURY AND/OR INJURY TO OTHERS AS WELL AS VEHICLE DAMAGE.**

FOR CALIFORNIA RESIDENTS ONLY-PROP 65 WARNING:

Some products may contain chemicals such as DEHP, which can cause cancer, birth defects or other reproductive harm.

