

INSTALLATION INSTRUCTIONS

FRONT TUBE FENDERS



APPLICATION:
2018-2019 Jeep Wrangler JL
PART NUMBER:
62-1025

CONTENT			
ITEM	QUANTITY	DESCRIPTION	TOOLS NEEDED
1,2	2	FRONT FENDER ASSEMBLY (1-DRIVER, 2-PASSENGER)	10MM SOCKET
3	2	FRONT CURVED DOUBLE-SIDED TAPE	10MM WRENCH
4	2	REAR CURVED DOUBLE-SIDED TAPE	13MM SOCKET
5	2	STRAIGHT DOUBLE SIDED TAPE	13MM WRENCH
6	1	11 FT OF WELTING	WIRE CRIMP TOOL
7	4	M6 PLATE	UTILITY KNIFE
8	4	M6X30MM BUTTON HEAD SCREW (BLACK ZINC)	HEAT GUN
9	8	M6X25MM BUTTON HEAD SCREW (BLACK ZINC)	RATCHET
10	6	M6X20MM BUTTON HEAD SCREW (BLACK ZINC)	TORQUE WRENCH
11	18	M6 SPLIT LOCK WASHER (BLACK ZINC)	
12	14	SMALL M6 FLAT WASHER (BLACK ZINC)	
13	4	LARGE M6 FLAT WASHER (BLACK ZINC)	
14	2	M8 BUTTON HEAD SCREW (BLACK ZINC)	
15	2	M8 SPLIT LOCK WASHER (BLACK ZINC)	
16	4	M8 FLAT WASHER (BLACK ZINC)	
17	2	M8 HEX NUT (BLACK ZINC)	
18	14	M6 SERRATED FLANGE NUT (YELLOW ZINC)	
19	8	HEAT SHRINK BUTT CONNECTOR	
20	1	M6 HEX KEY	

ANTI-SEIZE LUBRICANT MUST BE USED ON ALL STAINLESS STEEL FASTENERS TO PREVENT THREAD DAMAGE AND GALLING

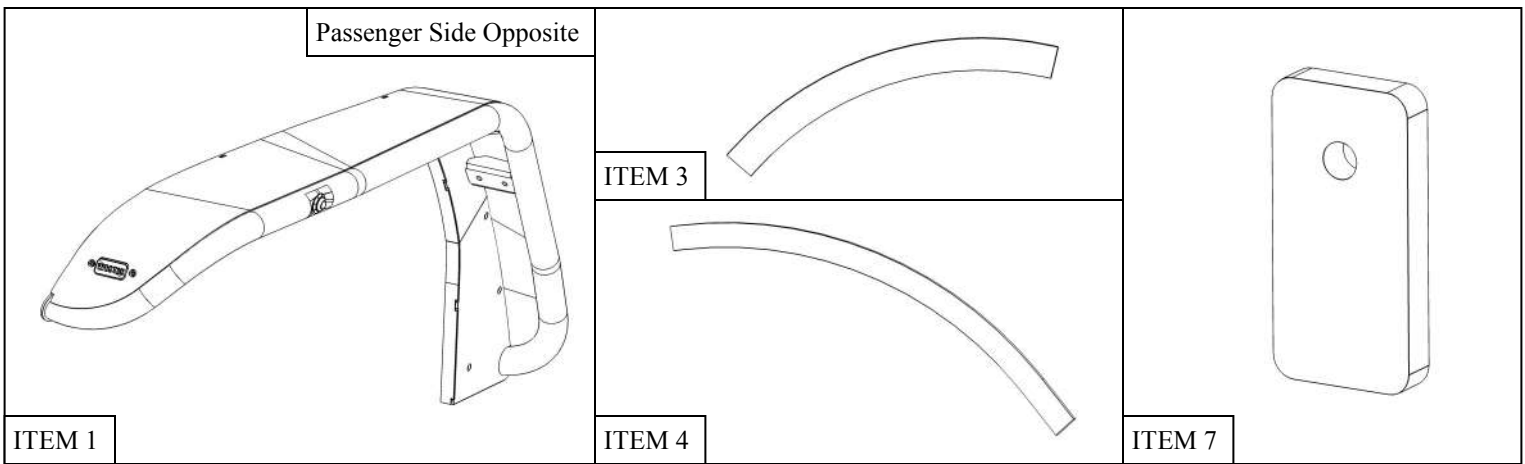

PROCEDURE

1. Remove contents from box, verify if all parts listed are present and free from damage.
Carefully read and understand all instructions before attempting installation.
Failure to identify damage before installation could lead to a rejection of any claim.

2. Remove the OEM Inner Liners as shown in **Steps 3-4**. If using the Westin Inner Fenders, skip to **Step 5** once Westin Inner Fenders are installed.
3. Remove the push pins and fasteners shown in **Figures 1-3**.

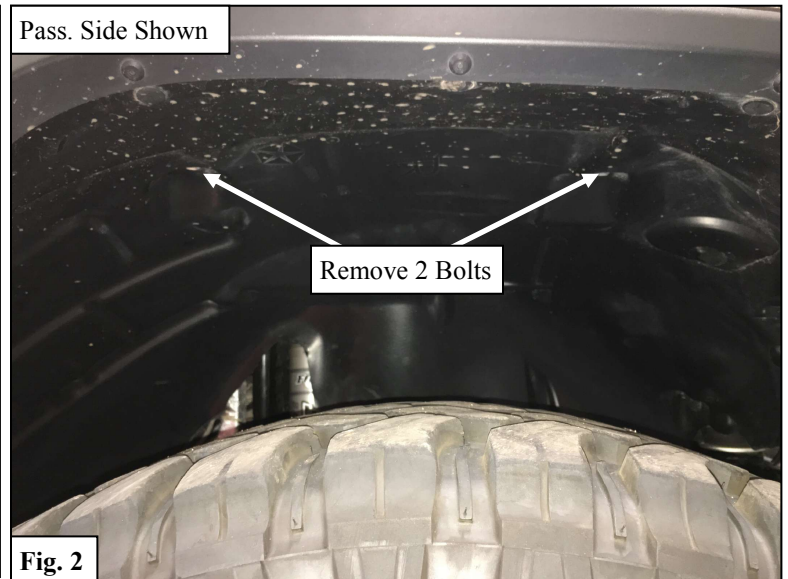

4. Remove the plastic rivets along the fender as necessary by pushing in the center of the rivet, releasing the rivet. See **Figure 4**. You may then remove the Inner Fender.

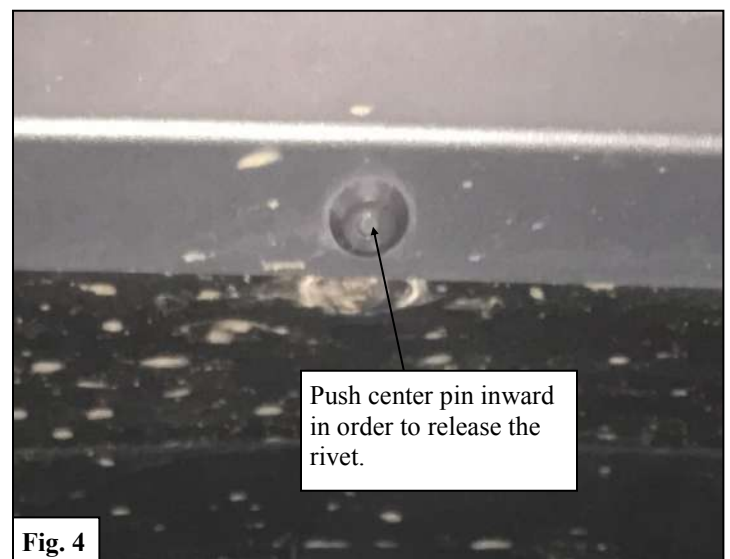

5. Remove the two bolts securing the OEM Fender to the top supports. See **Figure 5**.
6. Remove the bolt toward the front of the fender that secures the fender to the vehicle. See **Figure 6**.

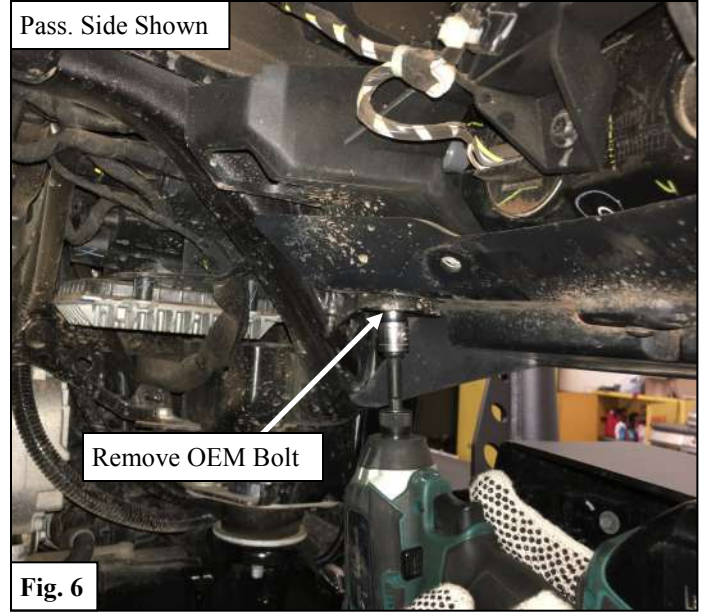
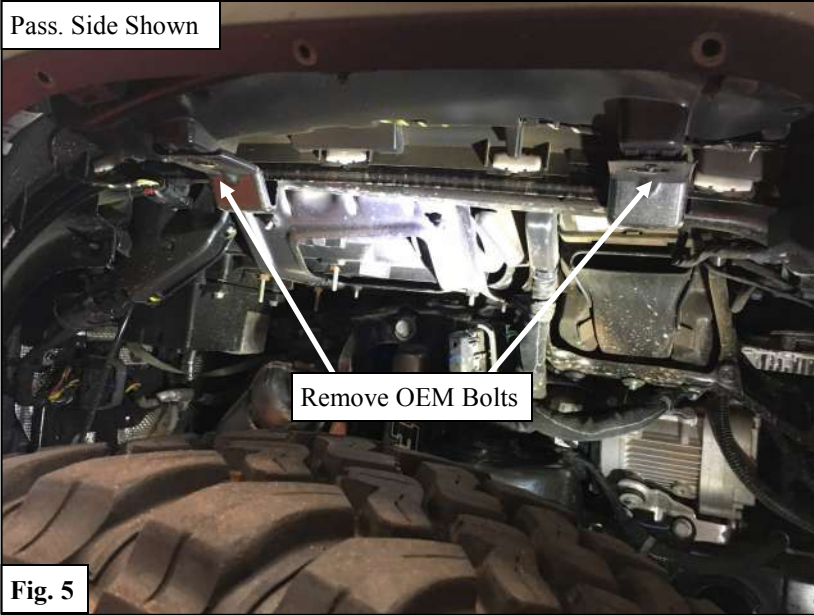

7. Unplug the wiring harness for the signal and marker lights. Do so by unplugging only the single plug at the top of the fender well. Slide the red locking tab back, and gently remove the plug. See **Figure 7**.
8. Remove the OEM Fender by removing the plastic clips around the fender. See **Figure 8**.

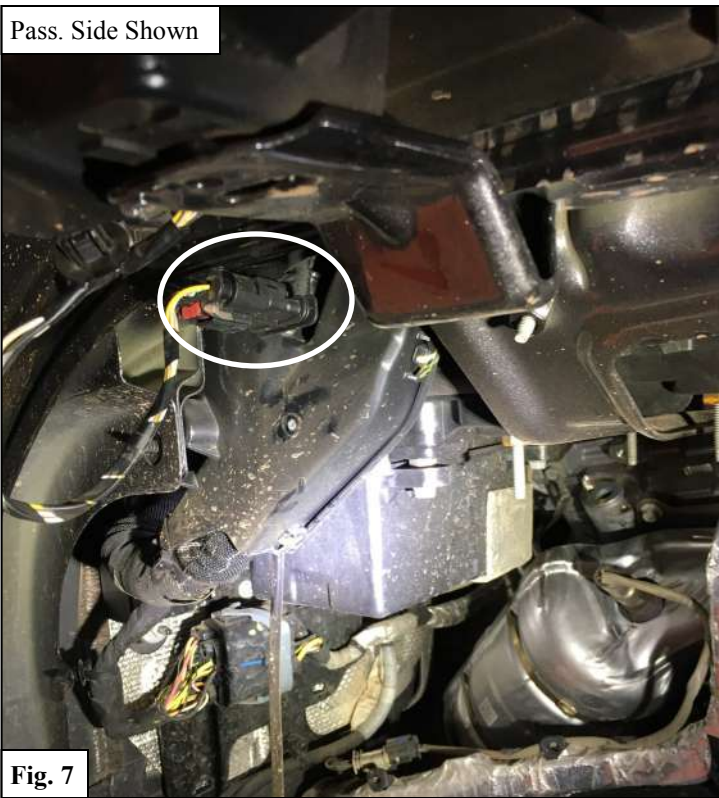

9. Install the Double Sided Tape (3-5) to the fender along the top edge. It will be necessary to trim around the holes. See **Figure 9**.
10. Attach the Welting (6) to the installed Double-Sided Tape (3-5). See **Figure 9**. *Note: The tubed part of the welting should stick just above the top of the fender.*

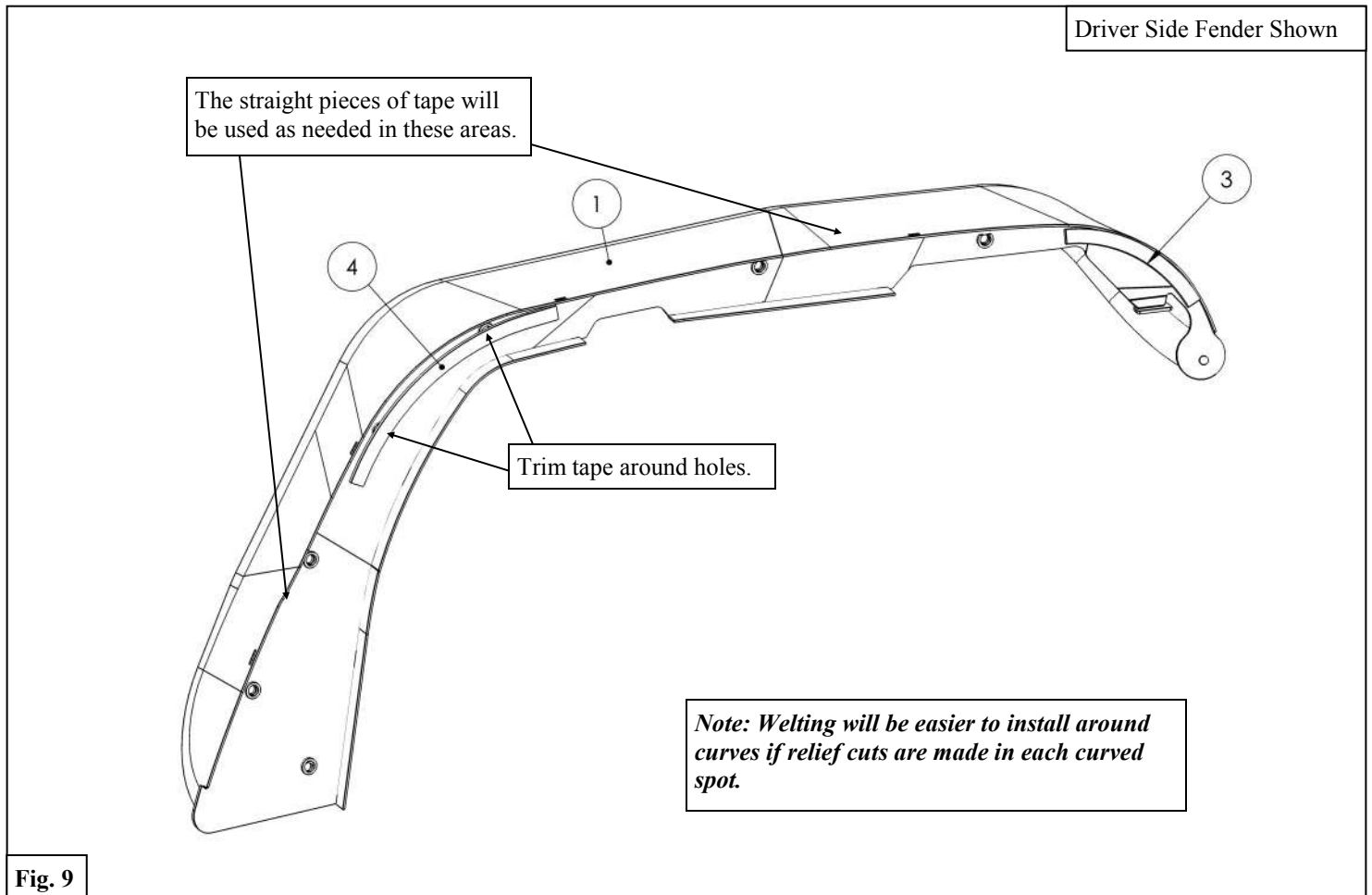

11. Place the Tube Fender (1,2) on the vehicle. First loosely attach the fender to the two upper supports using the supplied M6 Hardware and M6 Plate. See **Figure 10**.

12. Loosely secure the front mounting location of the fender using the supplied M8 Hardware. See **Figure 11**.

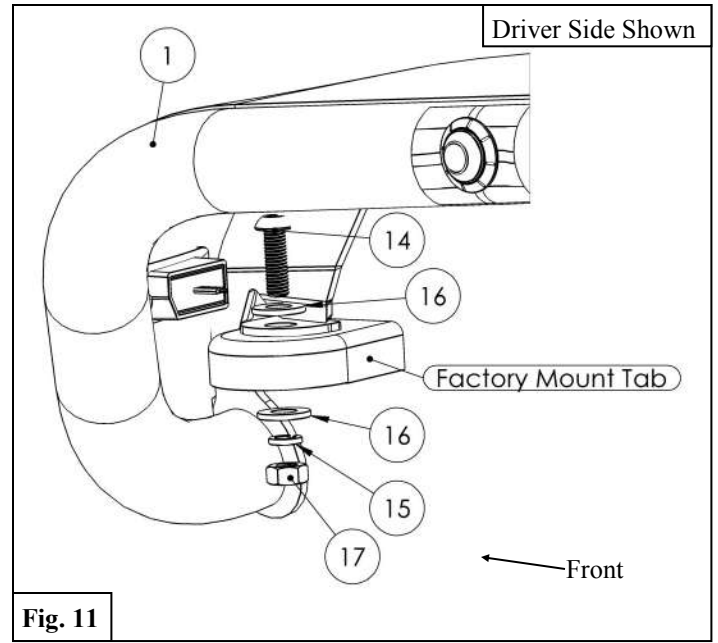
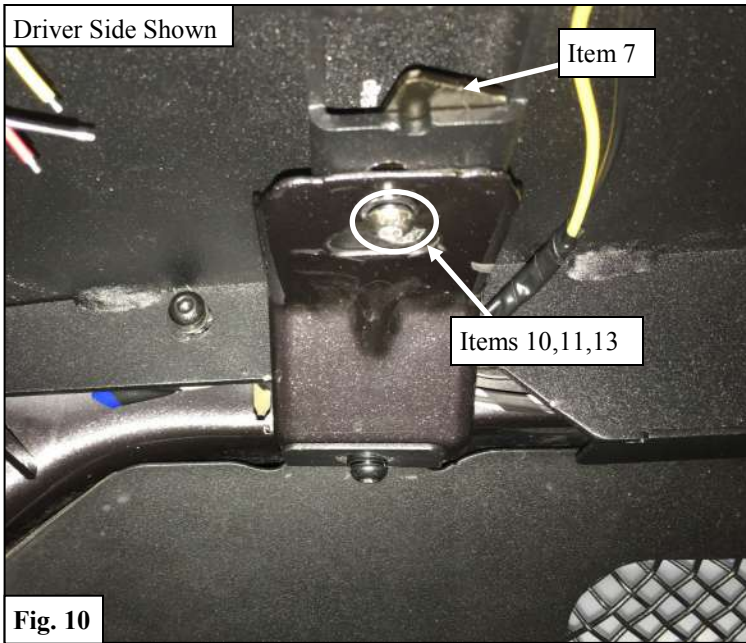

13. All mounting holes that line the perimeter of the fender will receive M6 Hardware. The various bolt lengths and their locations are indicated in **Figure 12** while the general hardware assembly to be used is shown in **Figure 13**.

14. Torque all hardware as specified: M6 to 7 ft-lbs, M8 to 18 ft-lbs.

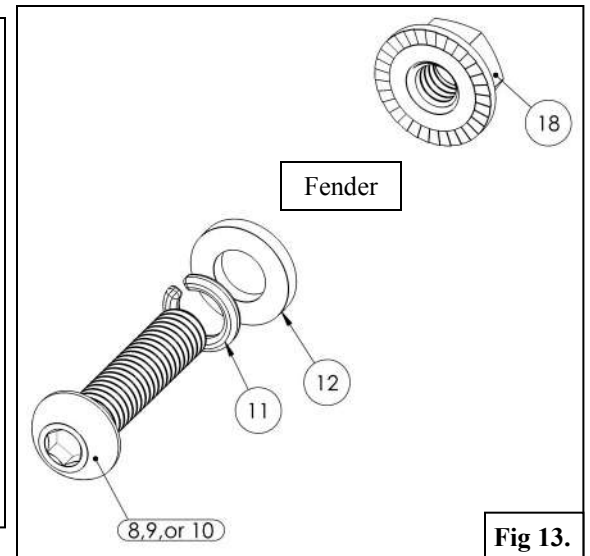
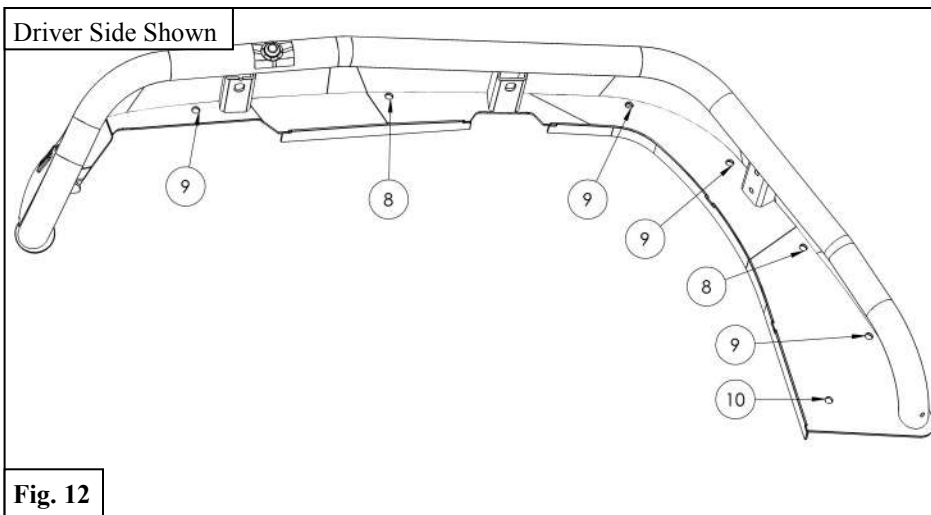

EXPLODED VIEW OF FENDER AND HARDWARE

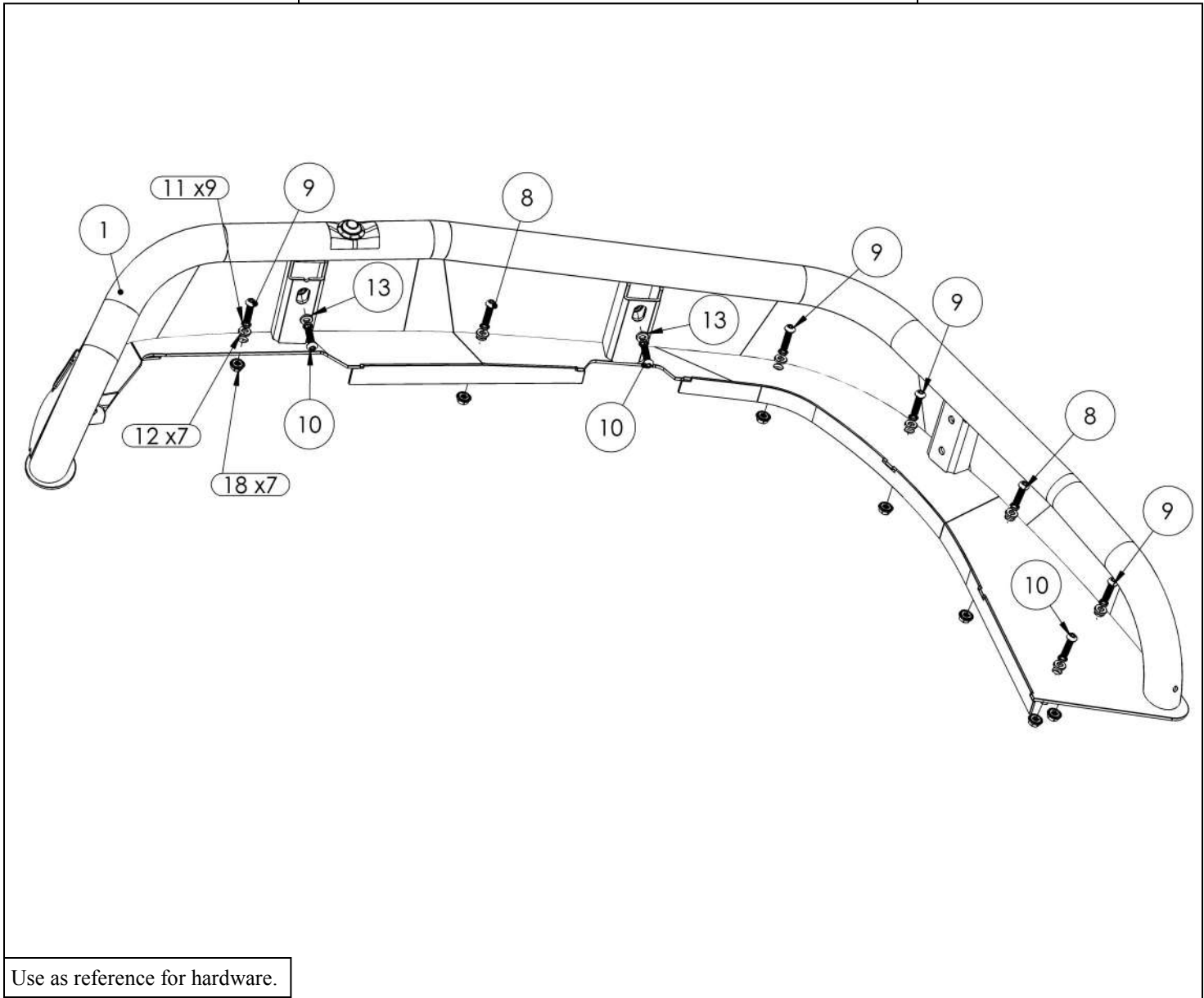

15. In order to connect the new marker and signal lights, remove the old harness from the OEM fender and cut the harness so that only the plug shown in **Figure 15** and wires remain. *Note: Cut the wires as close to the lights as possible.*
16. The new lights will be wired into the OEM harness using the supplied Connectors (19). See **Figure 14** for wiring details. *Note: after connecting the correct wires, use a heat gun to shrink the tubing on the connectors (19).*

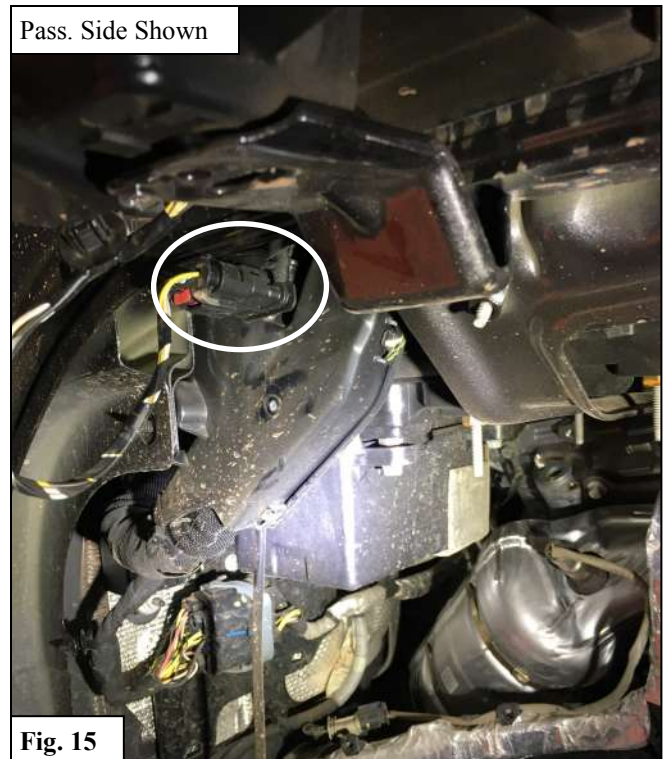
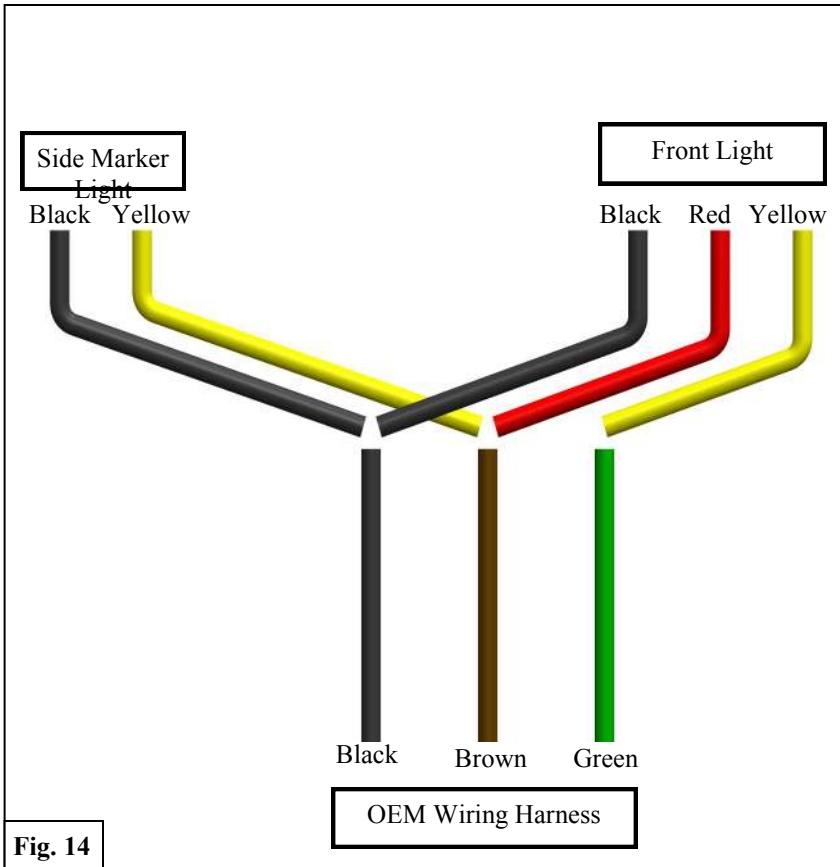

INSTALLATION COMPLETE



CARE INSTRUCTIONS

- REGULAR WAXING IS RECOMMENDED. DO NOT USE ANY TYPE OF POLISH OR WAX THAT MAY CONTAIN ABRASIVES.
- STAINLESS STEEL PRODUCTS CAN BE CLEANED WITH MILD SOAP AND WATER. STAINLESS STEEL POLISH SHOULD BE USED TO POLISH SMALL SCRATCHES.
- GLOSS BLACK FINISHES SHOULD BE CLEANED WITH MILD SOAP AND WATER

WESTIN



WARNING



Failure to follow these instructions could lead to death, personal injury, and / or property damage.

Failure to follow these instructions could lead to death, personal injury, and / or property damage.

FASTENERS:

All Westin supplied fasteners must be utilized and installed in accordance with the installation instructions and apply torque to the specifications as defined. **DOUBLE CHECK ALL FASTENERS BEFORE INITIAL USE, AND PERIODICALLY IN THE FUTURE TO ENSURE PROPER FUNCTION AND SAFETY.**

DRILLING:

Most Westin products do not require drilling for installation. If drilling is defined as required, use caution when drilling a vehicle. **FAILURE TO REVIEW AN AREA TO BE DRILLED MAY RESULT IN PERSONAL INJURY AND/OR INJURY TO OTHERS AS WELL AS VEHICLE DAMAGE.**

EYE PROTECTION:

ALWAYS WEAR SAFETY GLASSES OR GOGGLES DURING THE INSTALLATION PROCESS TO AVOID PERSONAL INJURY.

MAXIMUM TOWING/CARRYING CAPACITY: (if applicable)

The Westin Receiver Hitches will have a visible tow rating label affixed directly on the product. User should never exceed the vehicle manufacturers maximum tow and weight rating regardless of the capacity of the hitch. **FAILURE TO FOLLOW THESE GUIDELINES WILL VOID THE WESTIN WARRANTY AND MAY RESULT IN PERSONAL INJURY AND/OR INJURY TO OTHERS AS WELL AS VEHICLE DAMAGE.**

FOR CALIFORNIA RESIDENTS ONLY-PROP 65 WARNING:

Some products may contain chemicals such as DEHP, which can cause cancer, birth defects or other reproductive harm.

