

INSTALLATION INSTRUCTIONS

OFF-ROAD JACK MOUNT

WESTiN®

APPLICATION:
2007-2018 Jeep Wrangler JK
2018-2019 Jeep Wrangler JL
PART NUMBER:
59-89015

CONTENT			
ITEM	QUANTITY	DESCRIPTION	TOOLS NEEDED
1	1	OFF-ROAD JACK MOUNT	ALLEN WRENCH
2	1	HANDLE RETAINER BRACKET	10MM WRENCH
3	1	M10 NUT PLATE	
4	3	M10 QUICK RELEASE BOLT	
5	4	M6 BUTTON HEAD BOLT	
6	4	M6 FLAT WASHER	
7	4	M6 SERRATED FLANGE NUT	

ANTI-SEIZE LUBRICANT MUST BE USED ON ALL STAINLESS STEEL FASTENERS TO PREVENT THREAD DAMAGE AND GALLING

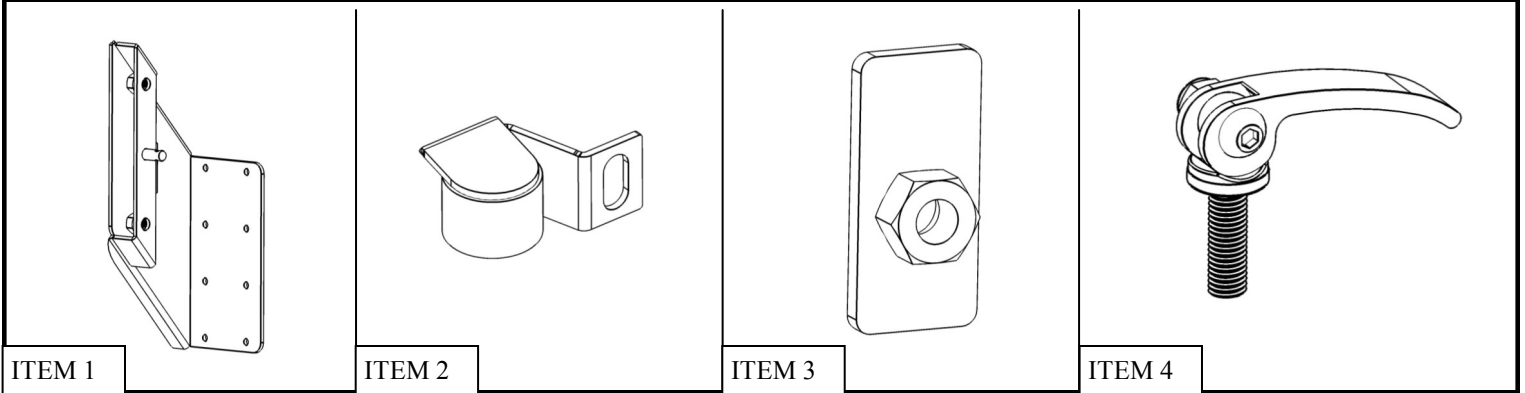

PROCEDURE

1. Remove contents from box, verify if all parts listed are present and free from damage.
Carefully read and understand all instructions before attempting installation.
Failure to identify damage before installation could lead to a rejection of any claim.

WESTiN

NOTE: Product designed to specifically fit WJ2 Tire Carriers

2. Attach the Jack Mount (1) to your WJ2 Tire Carrier (sold separately) using the supplied M6 Hardware. See **Figures 1 & 2**.
Note: The Jack Mount can be adjusted up and down using the various holes on the tire carrier and jack mount.

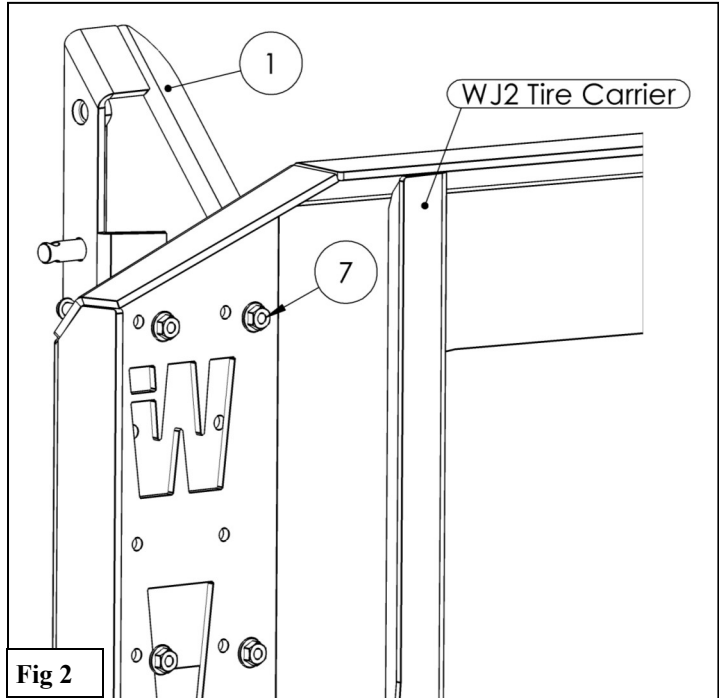
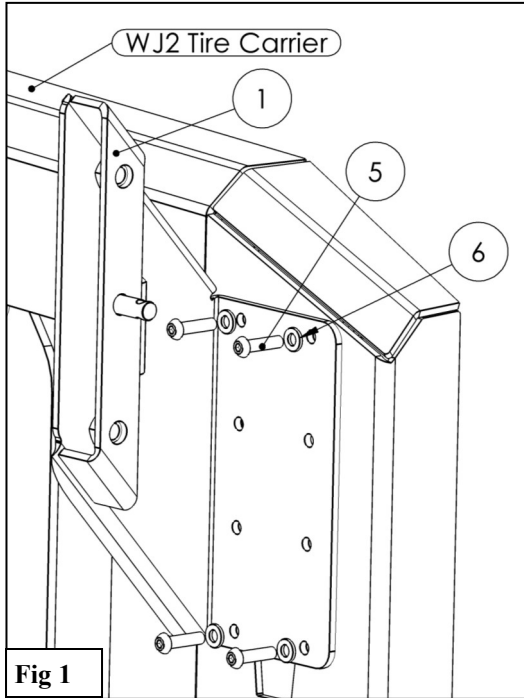

3. Install your off-road jack (not included) using two of the supplied M10 Quick Release Bolts (4). See **Figure 3**. *Note: the center pin on the jack mount can be used to assist you in order to hold the jack while installing the Quick Release Bolts.*

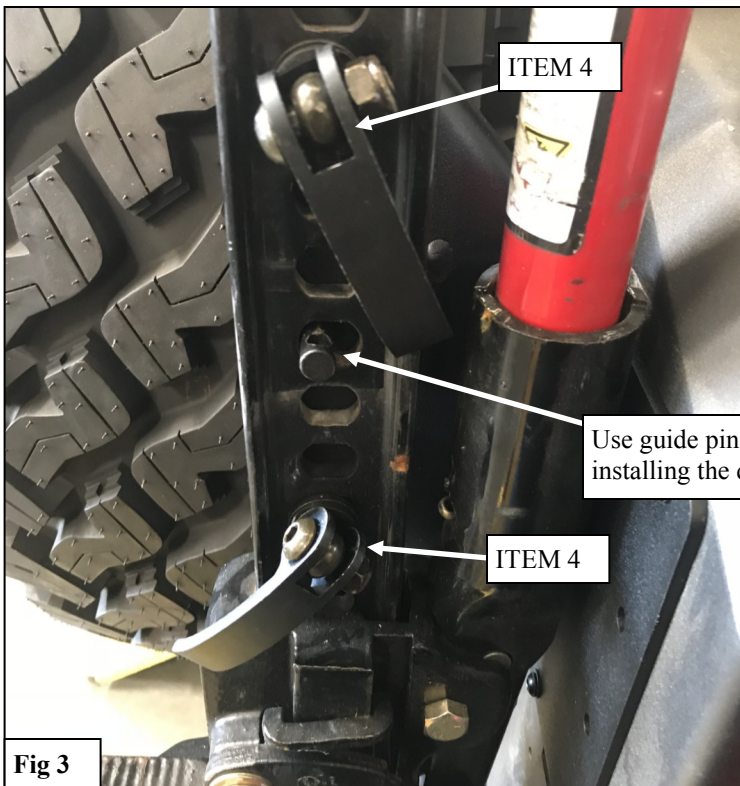

4. To install the Quick Release Bolts (4), thread them in as you would a normal screw but with the lever open. Just before the bolt gets tight, close the lever. Loosen or tighten the bolt as necessary by repeating this process until the jack feels secure.

5. The Handle Retainer Bracket (2) will be installed to the top of the jack. Using one Quick Release Bolt (4) and the M10 Nut Plate. See **Figure 4**.

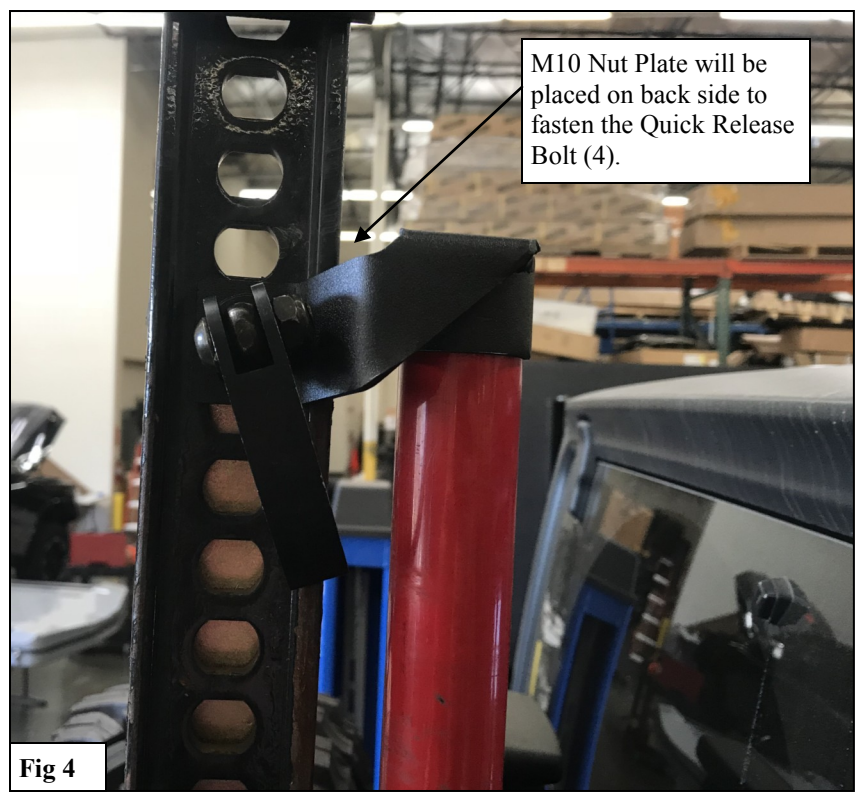

OPTIONAL FEATURE

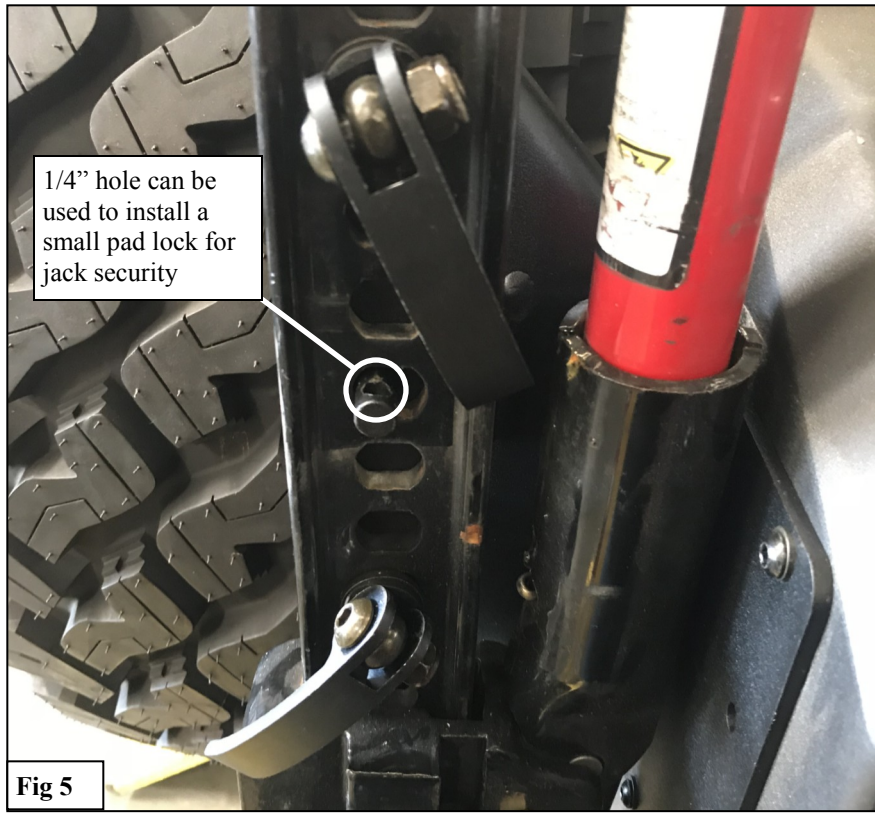

INSTALLATION COMPLETE



Jack not included; Tire Carrier sold separately

CARE INSTRUCTIONS

- REGULAR WAXING IS RECOMMENDED. DO NOT USE ANY TYPE OF POLISH OR WAX THAT MAY CONTAIN ABRASIVES.
- STAINLESS STEEL PRODUCTS CAN BE CLEANED WITH MILD SOAP AND WATER. STAINLESS STEEL POLISH SHOULD BE USED TO POLISH SMALL SCRATCHES.
- GLOSS BLACK FINISHES SHOULD BE CLEANED WITH MILD SOAP AND WATER

WESTIN



WARNING



Failure to follow these instructions could lead to death, personal injury, and / or property damage.

Failure to follow these instructions could lead to death, personal injury, and / or property damage.

FASTENERS:

All Westin supplied fasteners must be utilized and installed in accordance with the installation instructions and apply torque to the specifications as defined. **DOUBLE CHECK ALL FASTENERS BEFORE INITIAL USE, AND PERIODICALLY IN THE FUTURE TO ENSURE PROPER FUNCTION AND SAFETY.**

DRILLING:

Most Westin products do not require drilling for installation. If drilling is defined as required, use caution when drilling a vehicle. **FAILURE TO REVIEW AN AREA TO BE DRILLED MAY RESULT IN PERSONAL INJURY AND/OR INJURY TO OTHERS AS WELL AS VEHICLE DAMAGE.**

EYE PROTECTION:

ALWAYS WEAR SAFETY GLASSES OR GOGGLES DURING THE INSTALLATION PROCESS TO AVOID PERSONAL INJURY.

MAXIMUM TOWING/CARRYING CAPACITY: (if applicable)

The Westin Receiver Hitches will have a visible tow rating label affixed directly on the product. User should never exceed the vehicle manufacturers maximum tow and weight rating regardless of the capacity of the hitch. **FAILURE TO FOLLOW THESE GUIDELINES WILL VOID THE WESTIN WARRANTY AND MAY RESULT IN PERSONAL INJURY AND/OR INJURY TO OTHERS AS WELL AS VEHICLE DAMAGE.**

