

# INSTALLATION INSTRUCTIONS

WJ2 REAR BUMPER/ WJ2 REAR BUMPER WITH SENSORS

APPLICATION:

2020 Jeep Gladiator, 2020 Jeep Gladiator With Sensors

PART NUMBER:

59-82065, 59-82075



CONTENT			
ITEM	QUANTITY	DESCRIPTION	TOOLS NEEDED
1	1	REAR BUMPER	16MM SOCKET
2	2	LIGHTED SCREW	16MM WRENCH
3	8	M10 SPLIT LOCK WASHER	10MM SOCKET
4	12	M10 FLAT WASHER	10MM WRENCH
5	8	M10 HEX HEAD BOLT	21MM SOCKET
6	4	M10 HEX NUT	ALLEN WRENCH
7	4	M4 HEX NUT	RATCHET
8	4	M4 SPLIT LOCK WASHER	TORQUE WRENCH
9	4	M4 FLAT WASHER	PRY TOOL
10	4	M4 BUTTON HEAD SCREW	
11	4	YELLOW HEAT SHRINK CONNECTORS 22-24 GAUGE WIRE	
<b>FOR 59-82075 ONLY</b>			
12	4	M6 SERATED FLANGE NUT	
13	4	M6 FLAT WASHER	
14	4	M6 HEX HEAD BOLT	
15	4	PARKING SENSOR GASKET	
16	4	SENSOR L-TAB	
17	6	ZIP-TIES	
<b>ANTI-SEIZE LUBRICANT MUST BE USED ON ALL STAINLESS STEEL FASTENERS TO PREVENT THREAD DAMAGE AND GALLING</b>			
ITEM 1		59-82075	ITEM 15
			<p>59-82075 only</p>
ITEM 2			ITEM 16
			<p>59-82075 only</p>



## PROCEDURE

1. Remove contents from box, verify if all parts listed are present and free from damage.  
Carefully read and understand all instructions before attempting installation.  
**Failure to identify damage before installation could lead to a rejection of any claim.**

2. Remove the two nuts on either side holding on the bumper. Repeat on the other side. **See Figure 1**
3. Unplug all connections from the bumper. You will have to remove wire retainers from the frame **See Figure 2**

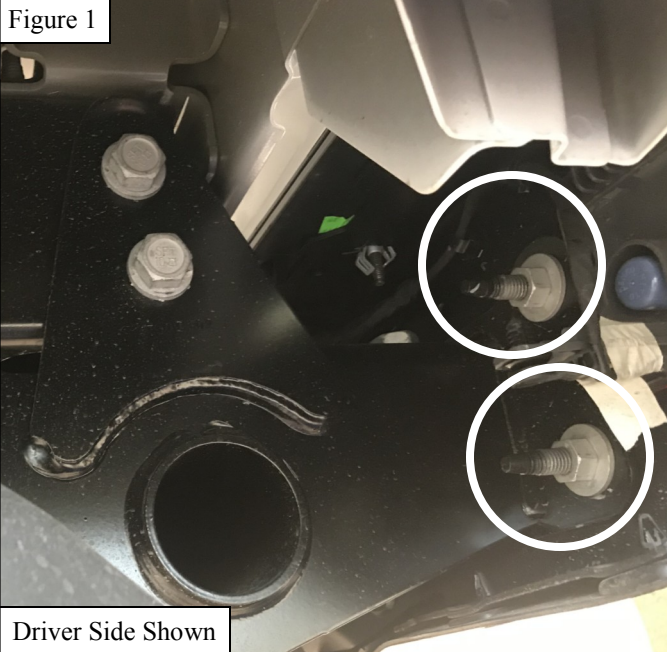

4. Remove the license plate. This will uncover two bolts. Remove these bolts and then remove the factory bumper.

## PARKING SENSOR INSTALLATION

5. Remove the four parking sensors from the OEM bumper. Pay attention to the orientation of the sensors. They must be installed in the same orientation. Handle sensors with care, they are very delicate .
6. Use the Sensor Tab (16), the Foam Gasket (15) (between tab and sensor), and the supplied M6 Hardware (12-14) to install the sensors in the four locations as shown in **Figure 3-5**.
7. Carefully route the harness around the bumper.

Note: Zip ties or double sided tape can be used to route harness and to hold the sensor in position.

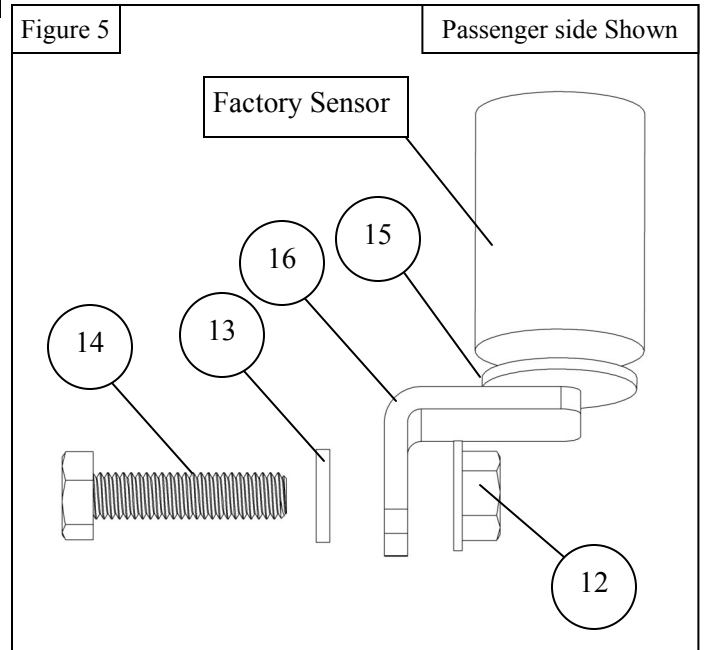
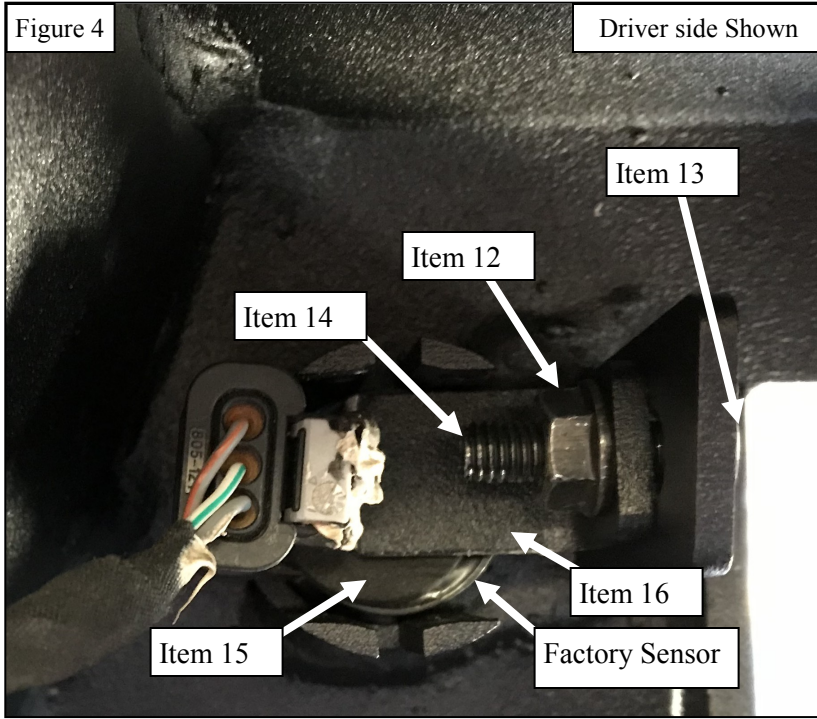
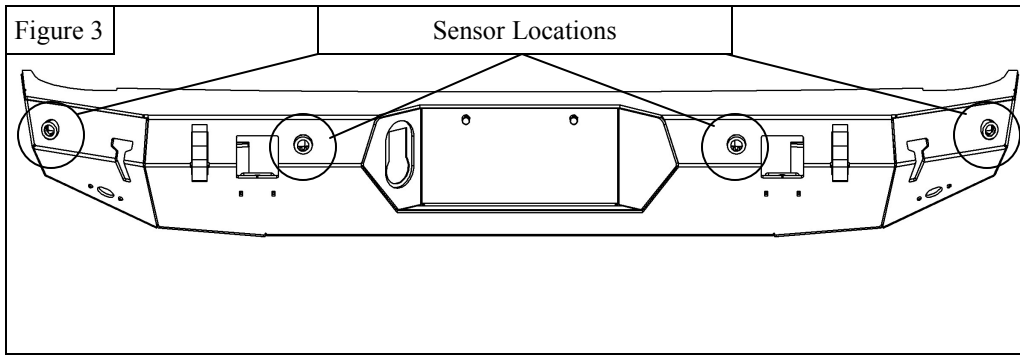

**OPTIONAL STEP**

8. Back up Lights can be installed in the two specified middle locations of the bumper. Install lights per manufacturers instructions. Install through the back side of the bumper. **See Figure 6.** *Note: It is recommended to install the lights in the bumper prior to mounting the bumper on the vehicle.*

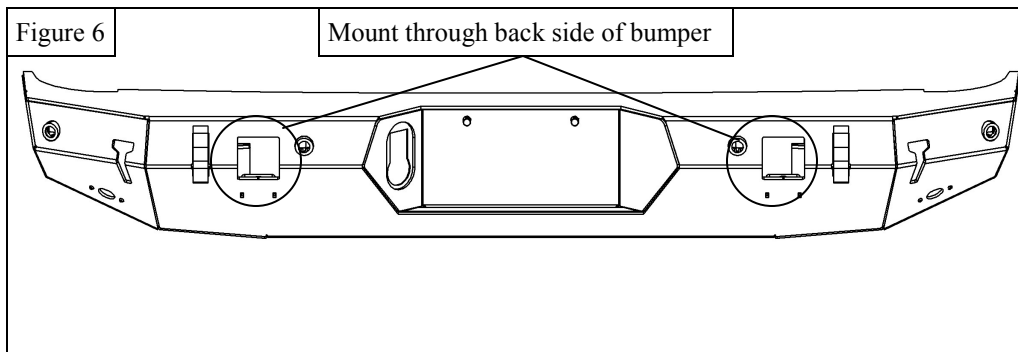

9. Using the supplied M10 hardware, loosely install the bumper to the vehicle. See Figure 7.

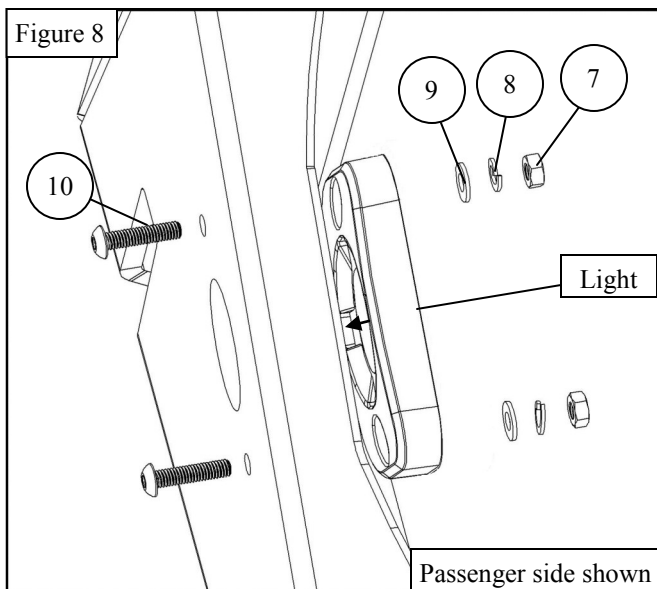
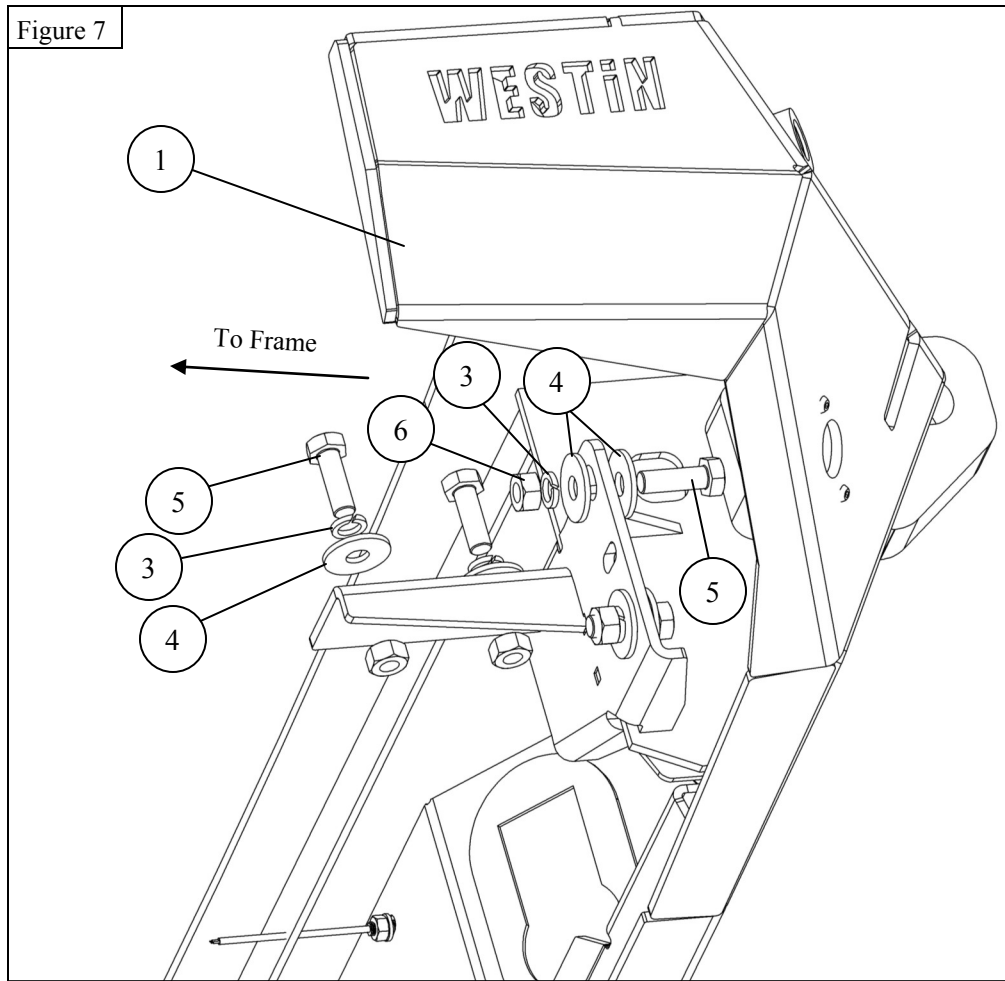

**OPTIONAL STEP:**

Rock Lights (sold separately) can be installed in the lower corners of the bumper using the supplied M4 hardware.

**Note:** Install lights per manufacturers instructions. See Figure 8.

10. **Optional Step:** The Trailer Plug may be installed for easier access to the trailer plug. It mounts in the specified location after being removed from the OEM Bumper. **See Figure 9**

11. Install the license plate to the bumper. It will be held on by the lighted screws.

*Note: The Lighted Screws (2) will attach in the top two holes of the License Plate mounting area . Use the factory license plate light harness to wire the Lighted Screws (2). Do so by using the supplied crimp connectors to splice the Lighted screw (6) wires into the factory harness. **Make sure to seal them using a heat gun afterwards.***

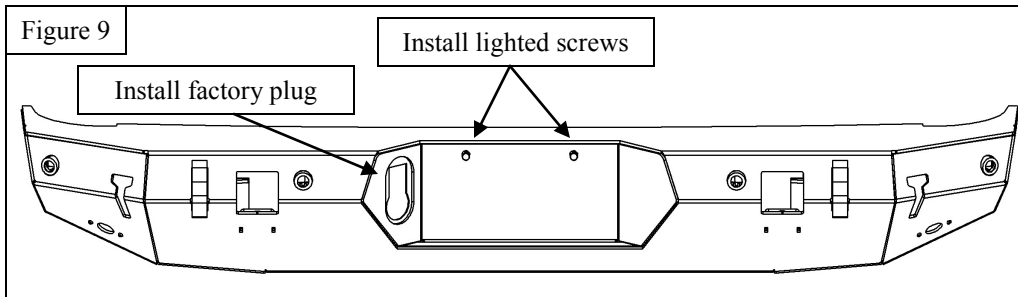

12. Adjust bumper as necessary and torque down all hardware to specified ft-lbs: M4 to 2 ft-lbs, M6 to 7 ft-lbs, M10 to 35-40 ft-lbs.

INSTALLATION COMPLETE



Lights sold separately

**CARE INSTRUCTIONS**

- REGULAR WAXING IS RECOMMENDED. DO NOT USE ANY TYPE OF POLISH OR WAX THAT MAY CONTAIN ABRASIVES.
- STAINLESS STEEL PRODUCTS CAN BE CLEANED WITH MILD SOAP AND WATER. STAINLESS STEEL POLISH SHOULD BE USED TO POLISH SMALL SCRATCHES.
- GLOSS BLACK FINISHES SHOULD BE CLEANED WITH MILD SOAP AND WATER.



## WARNING



Failure to follow these instructions could lead to death, personal injury, and / or property damage.

Failure to follow these instructions could lead to death, personal injury, and / or property damage.

### FASTENERS:

All Westin supplied fasteners must be utilized and installed in accordance with the installation instructions and apply torque to the specifications as defined. **DOUBLE CHECK ALL FASTENERS BEFORE INITIAL USE, AND PERIODICALLY IN THE FUTURE TO ENSURE PROPER FUNCTION AND SAFETY.**

### DRILLING:

Most Westin products do not require drilling for installation. If drilling is defined as required, use caution when drilling a vehicle. **FAILURE TO REVIEW AN AREA TO BE DRILLED MAY RESULT IN PERSONAL INJURY AND/OR INJURY TO OTHERS AS WELL AS VEHICLE DAMAGE.**

### EYE PROTECTION:

**ALWAYS WEAR SAFETY GLASSES OR GOGGLES DURING THE INSTALLATION PROCESS TO AVOID PERSONAL INJURY.**

### MAXIMUM TOWING/CARRYING CAPACITY: (if applicable)

The Westin Receiver Hitches will have a visible tow rating label affixed directly on the product. User should never exceed the vehicle manufacturers maximum tow and weight rating regardless of the capacity of the hitch. **FAILURE TO FOLLOW THESE GUIDELINES WILL VOID THE WESTIN WARRANTY AND MAY RESULT IN PERSONAL INJURY AND/OR INJURY TO OTHERS AS WELL AS VEHICLE DAMAGE.**

### FOR CALIFORNIA RESIDENTS ONLY-PROP 65 WARNING:

Some products may contain chemicals such as DEHP, which can cause cancer, birth defects or other reproductive harm.

