

# INSTALLATION INSTRUCTIONS



WJ2 REAR BUMPER

WJ2 REAR BUMPER W/ TIRE CARRIER

APPLICATION:

2018 Jeep Wrangler JL

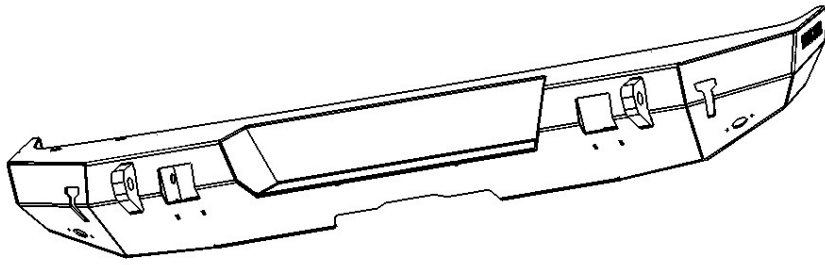
PART NUMBER:

59-82025, 59-82035

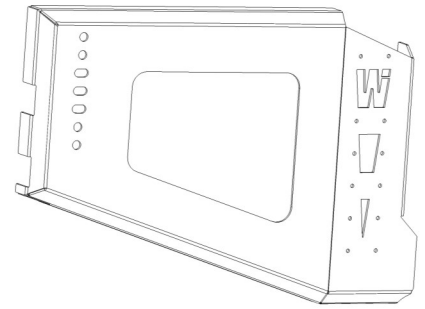
CONTENT			
ITEM	QUANTITY	DESCRIPTION	TOOLS NEEDED
1	1	REAR BUMPER ASSEMBLY	18MM SOCKET
2	1	TIRE CARRIER ASSEMBLY *59-82035 only	18MM WRENCH
3	2	M14 NUT PLATE	36MM SOCKET
4	1	SPINDLE *59-82035 only	10MM WRENCH
5	1	BEARING KIT *59-82035 only	RATCHET
6	1	TAILGATE MOUNT *59-82035 only	TORQUE WRENCH
7	1	TIRE MOUNT ASSEMBLY *59-82035 only	ALLEN WRENCH
8	1	RUBBER BUMPER BRACKET *59-82035 only	DRILL MOTOR
9	2	RUBBER BUMPER *59-82035 only	1/2" DRILL BIT
10	2	TURN BUCKLE ASSEMBLY *59-82035 only	15MM SOCKET
11	1	LICENSE PLATE RELOCATOR BRACKET	
12	1	BEARING CAP *59-82035 only	
13	1	TRAILER PLUG RELOCATOR BRACKET	
14	2	QUARTER PANEL CLOSEOUT PANEL (1 DRIVER, 1 PASSENGER)	
15	2	LIGHTED SCREW	
16	1	CHIMSEL LIGHT RELOCATOR *59-82035 only	
17	1	CAMERA MOUNTING & EXTENSION BRACKET *59-82035 only	
18	1	CORRUGATED SLEEVE	
19	4	M6 SPLIT LOCK WASHER	
20	2	M8 SERRATED FLANGE NUT	
21	8	M6 HEX NUT	
22	8	M14 HEX HEAD CAP SCREW	
23	8	M14 FLAT WASHER	
24	8	M14 SPLIT LOCK WASHER	
25	4	M4 HEX SOCKET BUTTON HEAD SCREW	
26	4	M4 FLAT WASHER	
27	4	M4 SPLIT LOCK WASHER	
28	4	M4 HEX NUT	



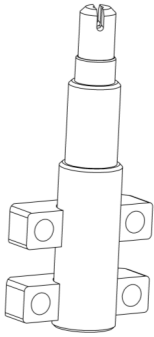
<b>CONTENT</b>			
<b>4ITEM</b>	<b>QUANTITY</b>	<b>DESCRIPTION</b>	
29	16	M6 FLAT WASHER *8 for 59-82035 only	
30	4	M6 HEX SOCKET BUTTON HEAD BOLT	
31	2	M8 SQUARE NECK CARRIAGE BOLT	
32	3	M3 PHILLIPS HEAD SCREW *59-82035 only	
33	4	M5 FLAT WASHER *59-82035 only	
34	4	M5 EXTERNAL TOOTH LOCK WASHER *59-82035 only	
35	4	M5 HEX SOCKET BUTTON HEAD SCREW *59-82035 only	
36	4	M12 HEX SOCKET BUTTON HEAD SCREW *59-82035 only	
37	8	M8 HEX SOCKET BUTTON HEAD BOLT *59-82035 only	
38	16	M12 FLAT WASHER *59-82035 only	
39	6	M12 SPLIT LOCK WASHER *59-82035 only	
40	6	M12 HEX NUT *59-82035 only	
41	8	M8 SPLIT LOCK WASHER *59-82035 only	
42	8	M8 FLAT WASHER *59-82035 only	
43	6	M12 HEX HEAD CAP SCREW *59-82035 only (2x 20mm, 2x 80mm, 2x 90mm)	
44	1	M4 PAN HEAD PHILLIPS SCREW *59-82035 only	
45	2	M12 NYLOCK NUT *59-82035 only	
46	4	M6 NYLOCK NUT *59-82035 only	
47	4	M6 HEX SOCKET HEAD SCREW *59-82035 only	
48	2	M10 SERRATED FLANGE NUT *59-82035 only	
49	2	M10 SERRATED FLANGE BOLT *59-82035 only	
50	1	M24 CASTLE NUT *59-82035 only	
51	1	M8 SET SCREW *59-82035 only	
52	4	SPINDLE SHIM *59-82035 only	
53	1	4MM SQUARE KEYSTOCK *59-82035 only	
54	4	M12 CLASS 10.9 HEX HEAD CAP SCREW *59-82035 only	
55	4	M12 HEAVY FLAT WASHER 5MM THICK *59-82035 only	
56	4	M12 HARDENED SPLIT LOCK WASHER *59-82035 only	
57	3	LUG NUT *59-82035 only	
<b>ANTI-SEIZE LUBRICANT MUST BE USED ON ALL STAINLESS STEEL FASTENERS TO PREVENT THREAD DAMAGE AND GALLING</b>			



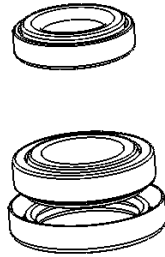
ITEM 1



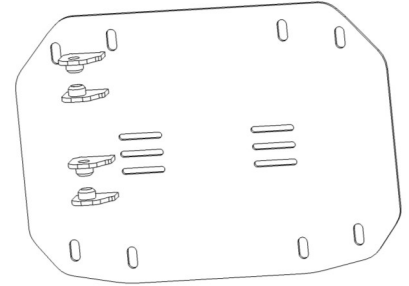
ITEM 2



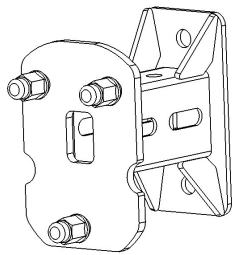
ITEM 4



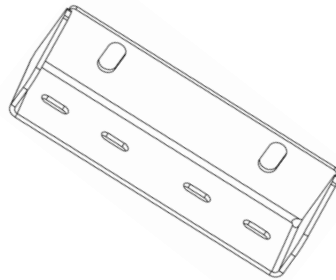
ITEM 5



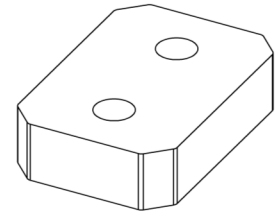
ITEM 6



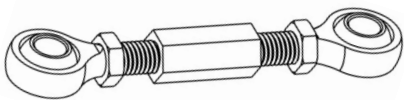
ITEM 7



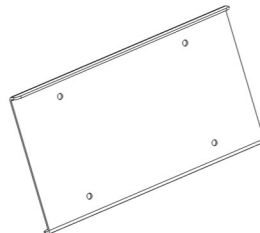
ITEM 8



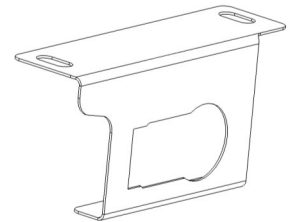
ITEM 9



ITEM 10

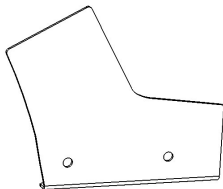


ITEM 11

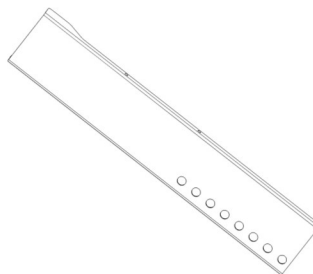


ITEM 13

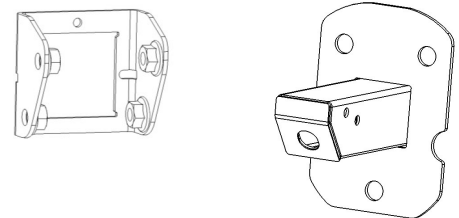
Driver's Side Shown



ITEM 14



ITEM 16



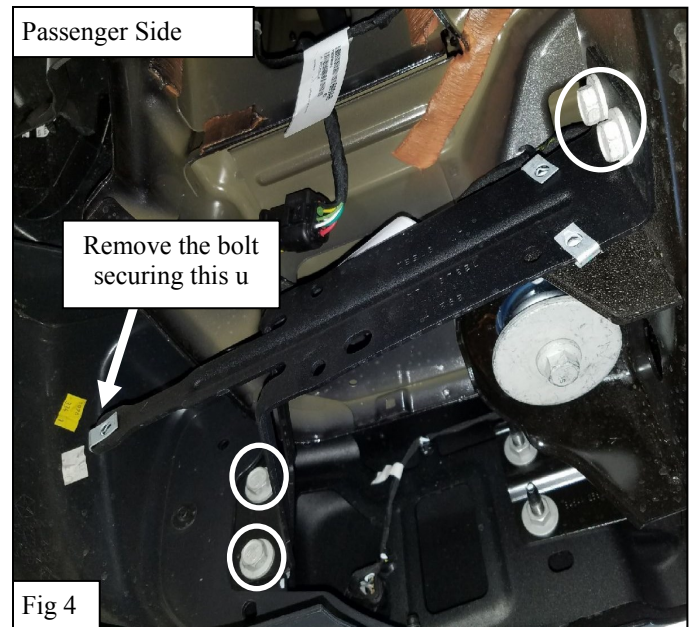
ITEM 17

## PROCEDURE

1. Remove contents from box, verify if all parts listed are present and free from damage. Carefully read and understand all instructions before attempting installation.  
**Failure to identify damage before installation could lead to a rejection of any claim.**
2. Begin by removing the 3 bolts securing the plastic trim on either side. See **Figure 1**.
3. Remove the bolts holding the bumper and recovery hook (if equipped) on both sides. See **Figures 2 & 3**.



4. Remove the bolt securing the support bracket on either side along either the bolts securing the bracket to the frame and bumper. See **Figure 4**.





5. Using a 16mm socket, remove the bottom two bumper bolts and the two trailer plug bracket bolts. See **Figure 5**.
6. Carefully Remove the OEM Bumper.



Fig 5

7. Slide the M14 Nut Plate (3) into the frame. Then, lift the WJ2 Rear Bumper Assembly (1) onto the frame Rails. See **Figure 6**.
8. Using the supplied M14 Hardware (22-24) secure the bumper to the frame in the same bolt locations as the OEM bumper. See **Figure 7**.

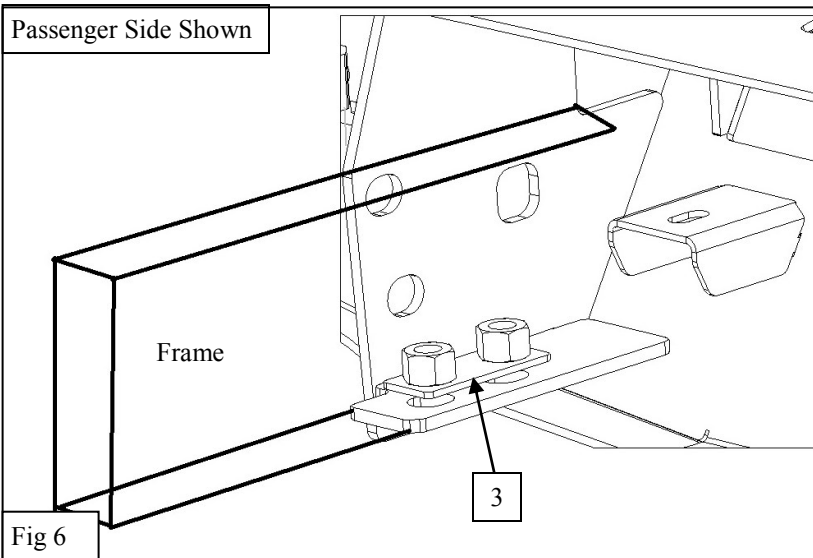


Fig 6

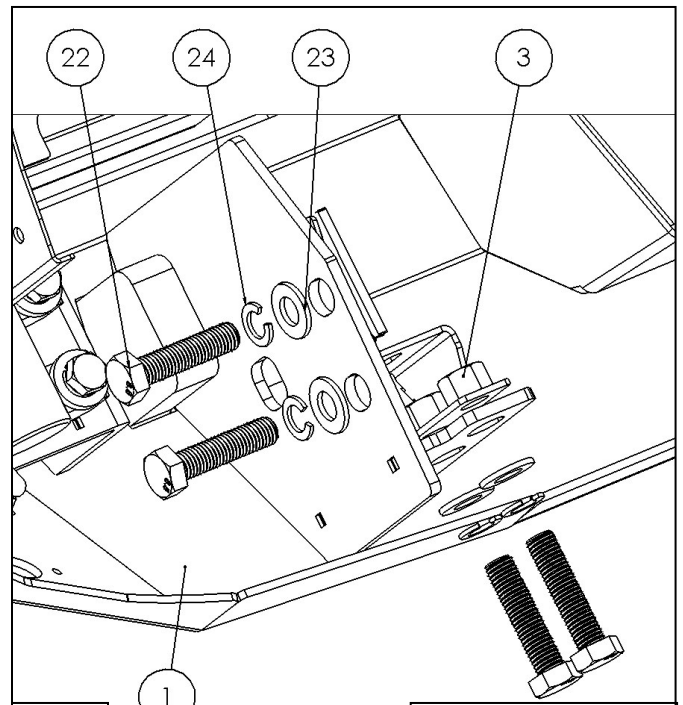


Fig 7

Passenger Side Shown

*Note: Bumper will slide over the frame rail and will use the supplied Nut Plates (3) and factory Nut Plates.*

9. Install the spindle (4) onto the bumper using the supplied M12 Hardware. See **Figure 8**. *Note— do not fully tighten at this time.* \*This step is only taken for 59-82035 **Important: Use the Class 10.9 Hardware & thick washers to mount the spindle.**

IT IS IMPORTANT TO USE THE CLASS 10.9 HARDWARE

Class 10.9

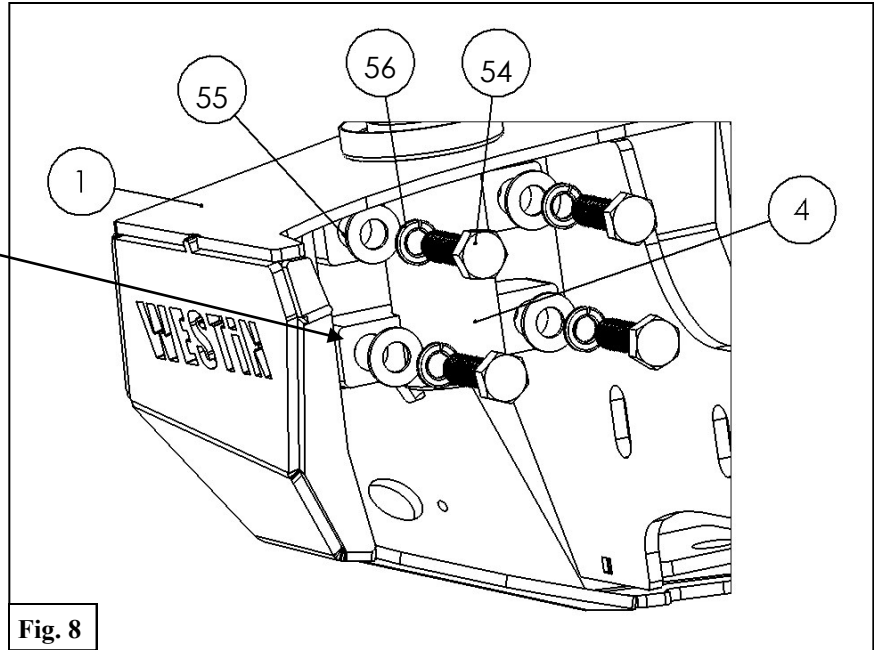


Fig. 8

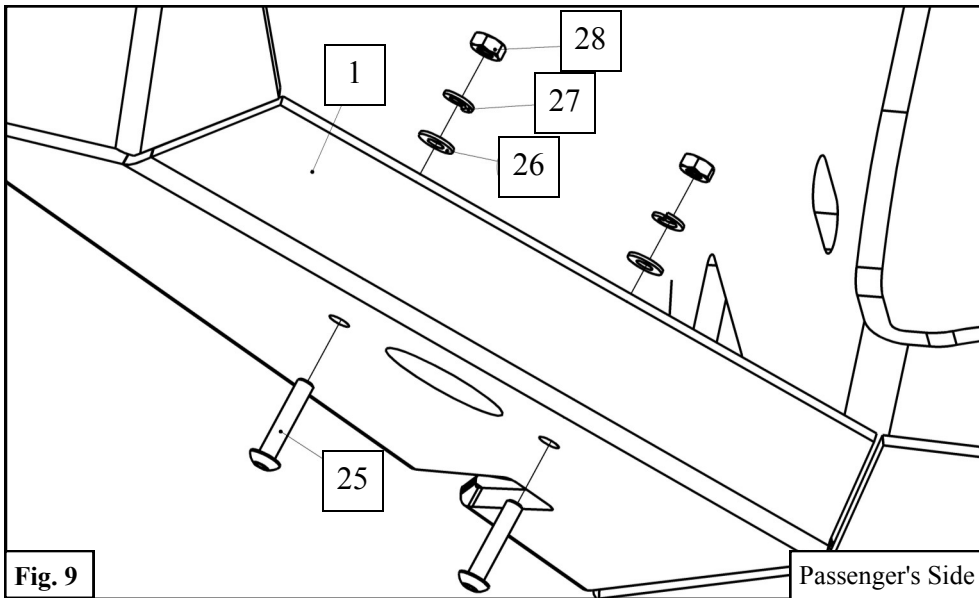


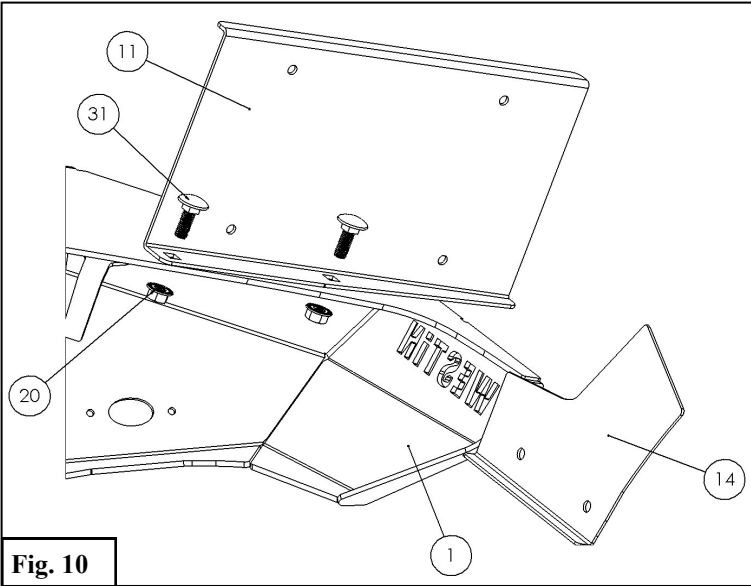
Fig. 9

Optional Step:

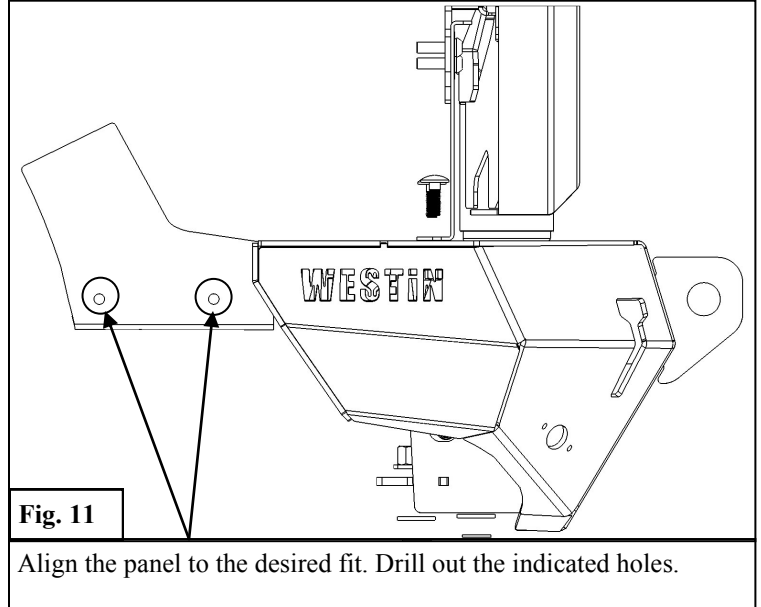
Lights (sold separately) can be installed in the lower corners of the bumper using the supplied M4 hardware.

**Note:** Install lights per manufacturers instructions. See **Figure 9**.

10. Next, install the License Plate Relocation Bracket (11) using the supplied M8 Hardware. **See Figure 10.**
11. **Optional Step:** The Trailer Plug Relocator Bracket may be installed for easier access to the trailer plug. It mounts in the stock location using the factory hardware.



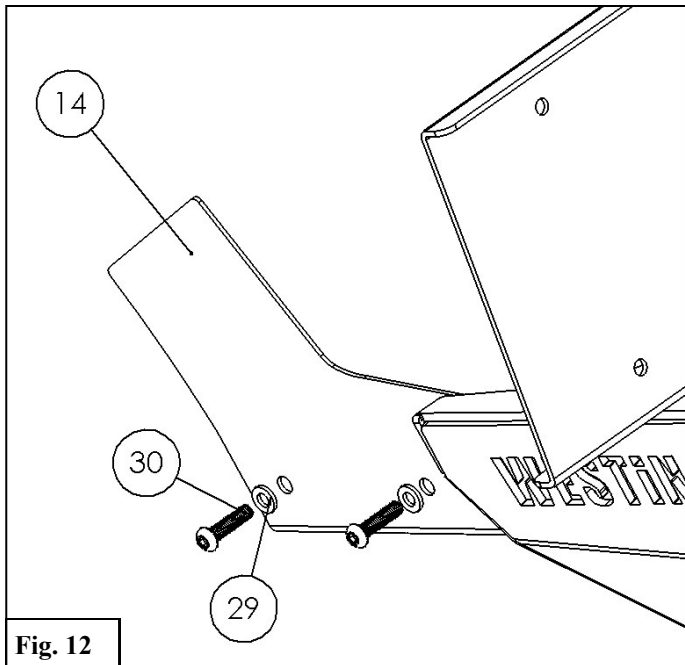
**Fig. 10**



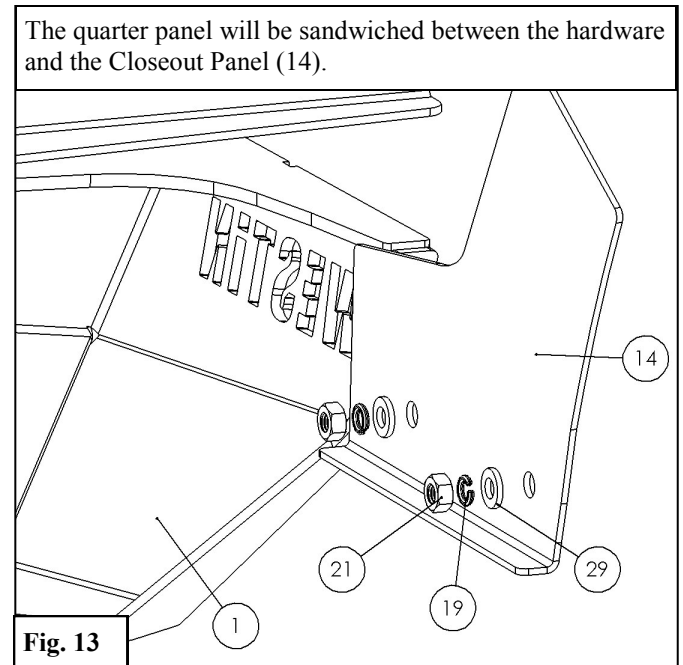
**Fig. 11**

Align the panel to the desired fit. Drill out the indicated holes.

12. Installation of the Quarter Panel Closeout Panels (14) will use the supplied M6 Hardware. For installations, align the Closeout Panel with the WJ2 Rear Bumper as shown in **Figure 11.**
13. Once the panel is positioned, mark and drill the two mounting holes using a 1/4" drill bit. Then, install with the M6 Hardware. **See Figures 11-13.**



**Fig. 12**



**Fig. 13**

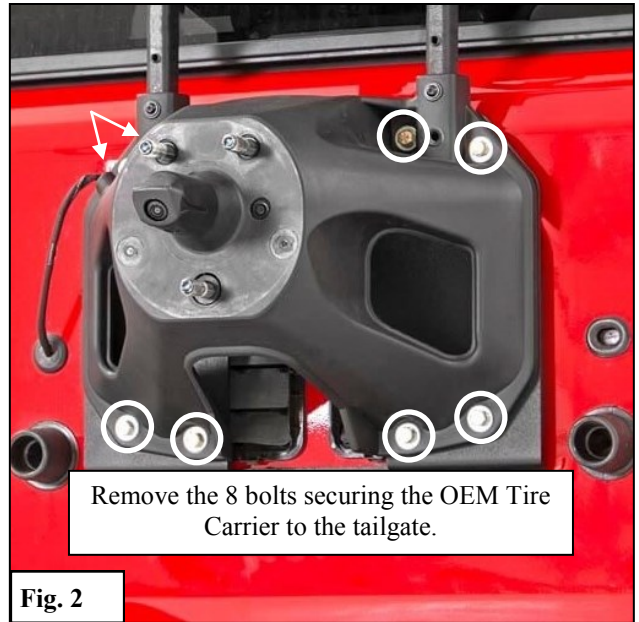


## Tire Carrier Installation (59-82035 only)

1. Use a T40 bit to remove the lock from the camera. See **Figure 1**.
2. Remove the spare tire at this time.
3. Remove all bolts to the factory tire carrier. See **Figure 2**.



**Fig. 1**



**Fig. 2**

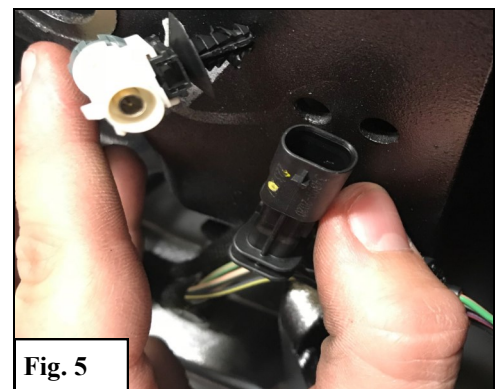
4. After removing the Tire Carrier, trace back the wiring for the brake light and rear camera. Pry off the inside tailgate trim to access the inside of the tailgate. See **Figure 3**.
5. From the inside of the tailgate, pry out the inner vent. See **Figure 4**.
6. Unplug both the camera and brake light wiring and remove them from the carrier and set aside. See **Figure 5**.



**Fig. 3**



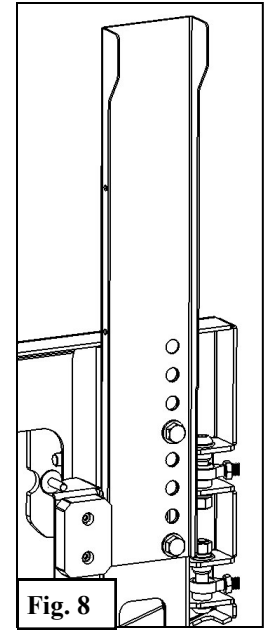
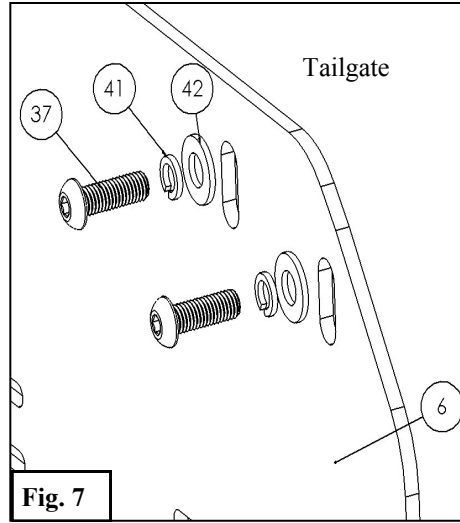
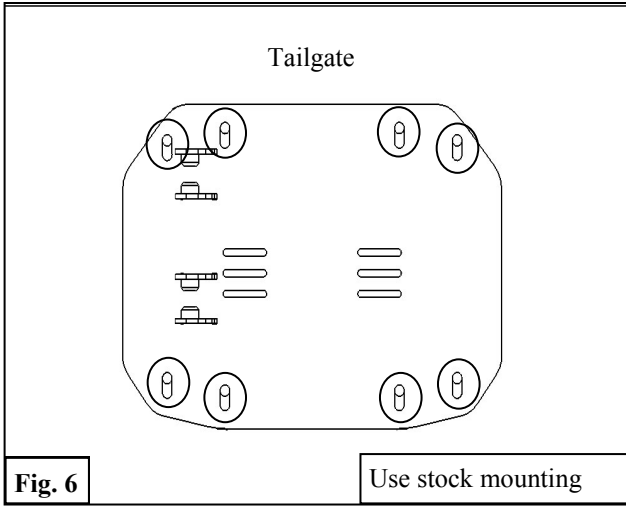
**Fig. 4**



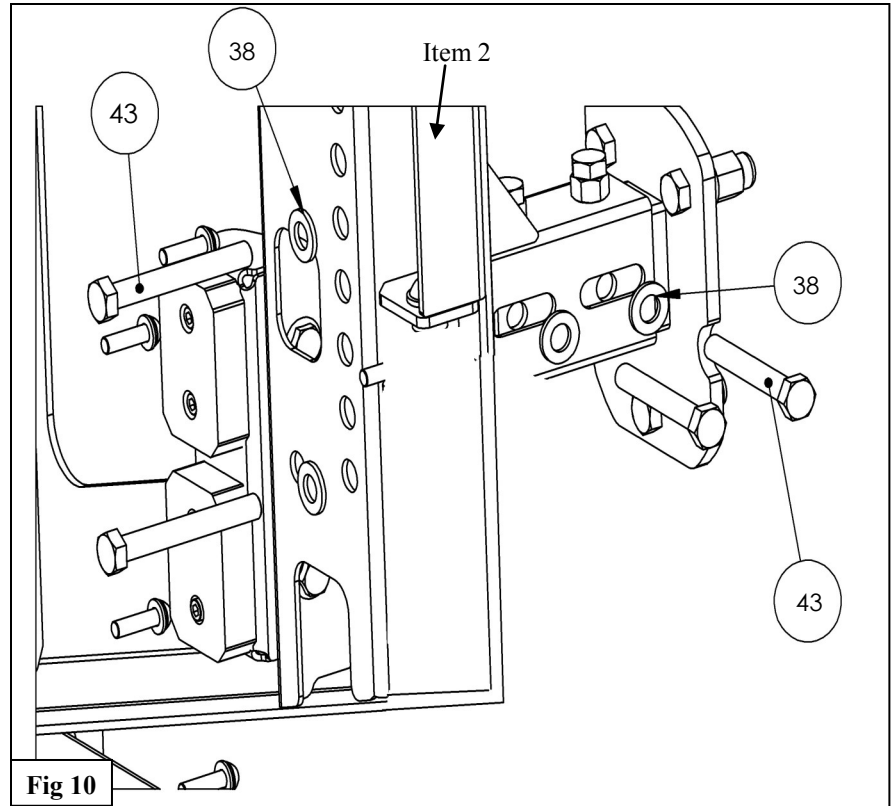
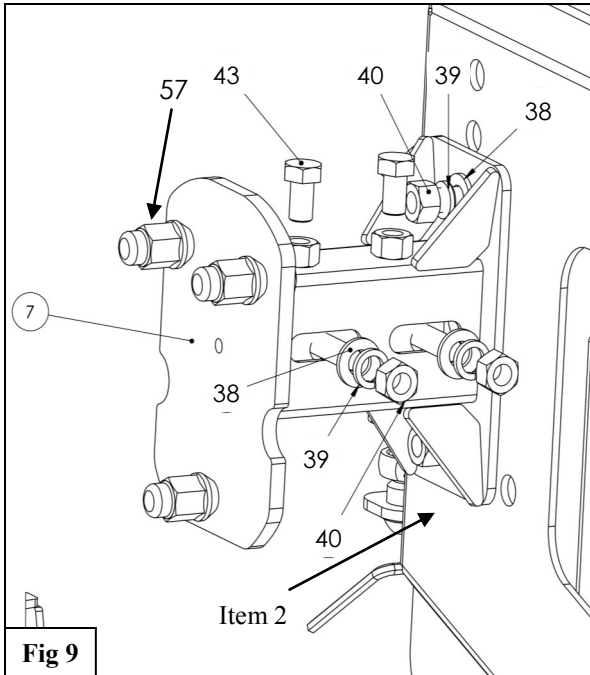
**Fig. 5**



7. The Tailgate Mount (6) will attach to the tailgate using the factory tire carrier mounting holes. See Figure 6.
8. Install the Tailgate Mount (6) using the supplied M8 Hardware. See Figure 7.

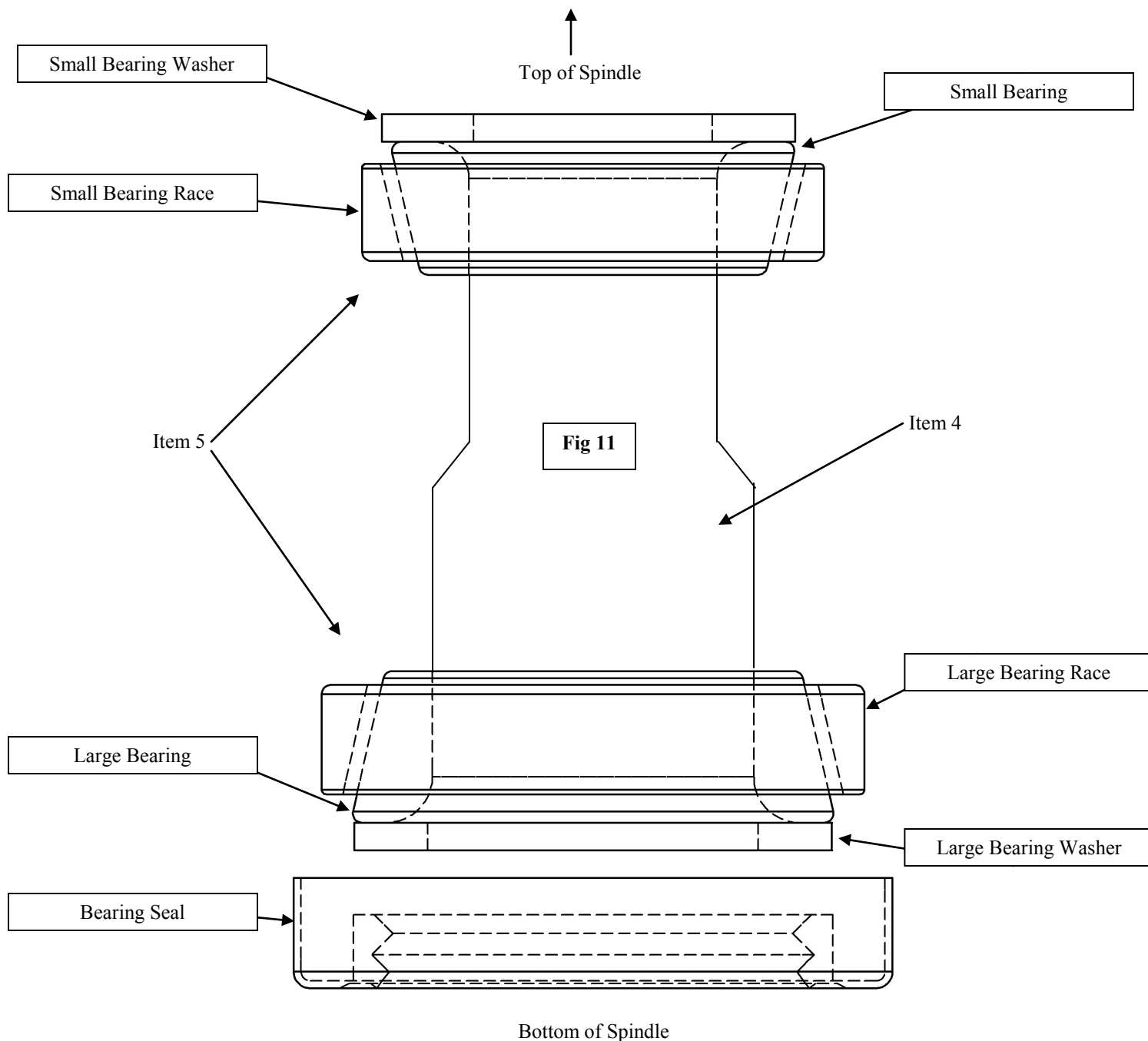


9. Install the Tire Mount (7) to the Tire Carrier (2) along with the Chimsel Light Relocator (16) using the supplied M12 Hardware. See Figures 8-10. Note:

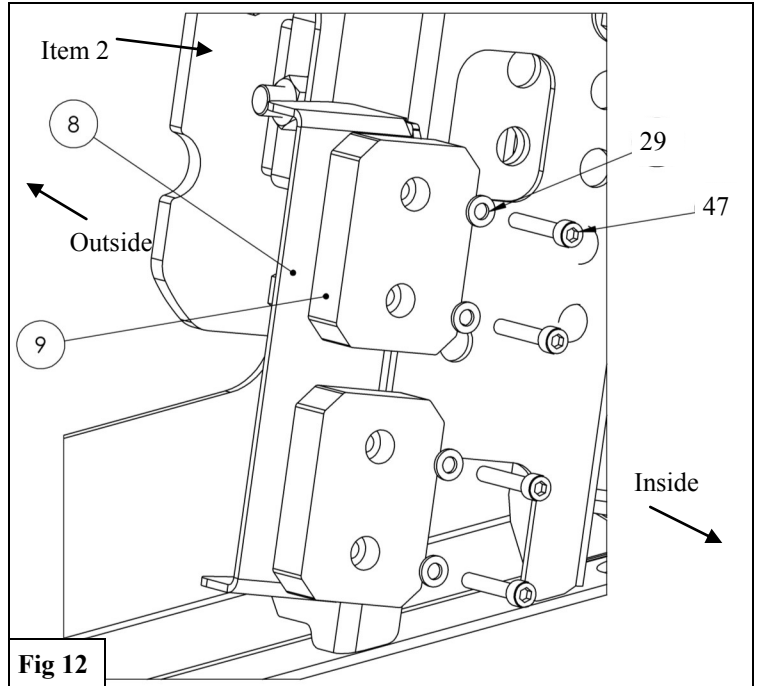
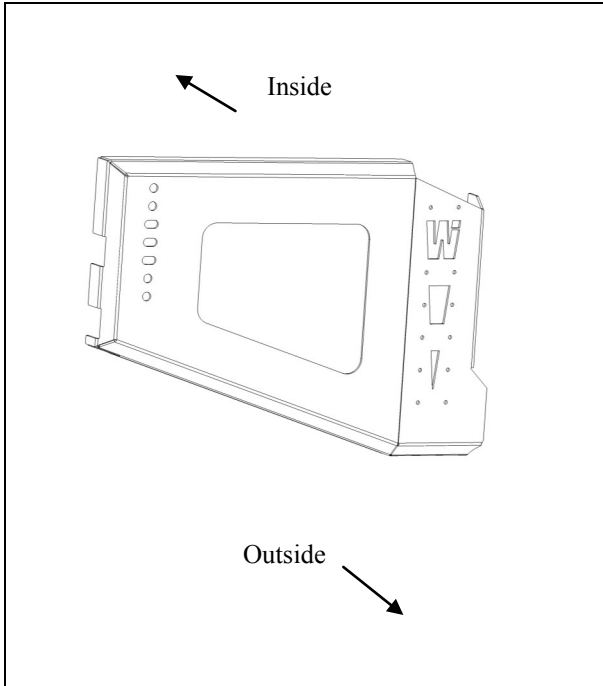


## 10. Bearing Installation

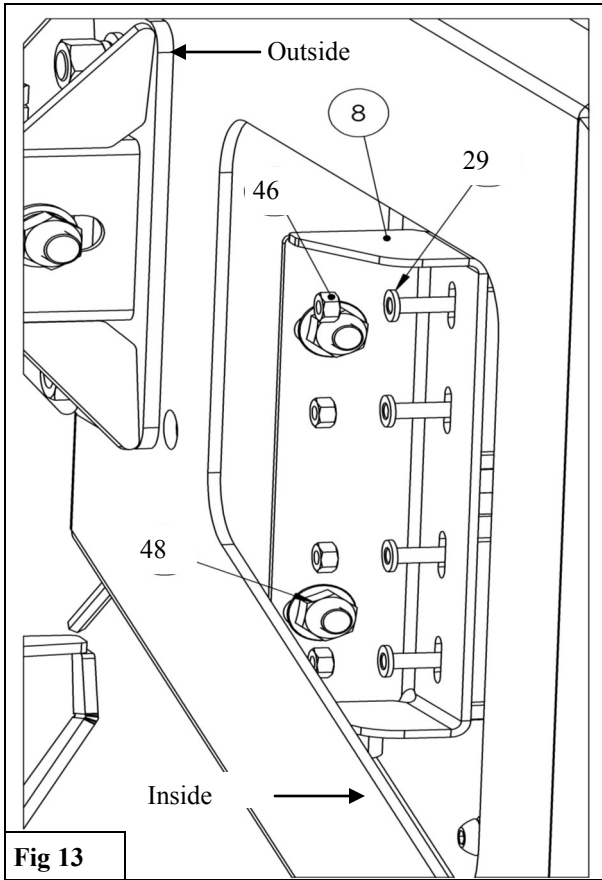
- A. Obtain the Bearing Kit (5).
- B. Identify the large bearing, race, and seal.
- C. Turn the Tire Carrier over so that the bottom of the spindle tube is facing up.
- D. Insert the bearing race into the tube with the tapered side facing up. **See Figure 11.**
- E. Place a generous amount of grease (not included) in the palm of your hand, and tap the bearing repeatedly in the grease until grease is spread throughout the rollers in the bearing.
- F. Place the bearing into the race as oriented in **Figure 11.**
- G. Place the large bearing washer on top of the bearing. **See Figure 11.**
- H. Using a soft hammer, tap the seal into place until flush with the bottom of the spindle tube on the tire carrier. **See Figure 11.**
- I. Repeat steps B-G for the small bearing with the tire carrier turned right side up.



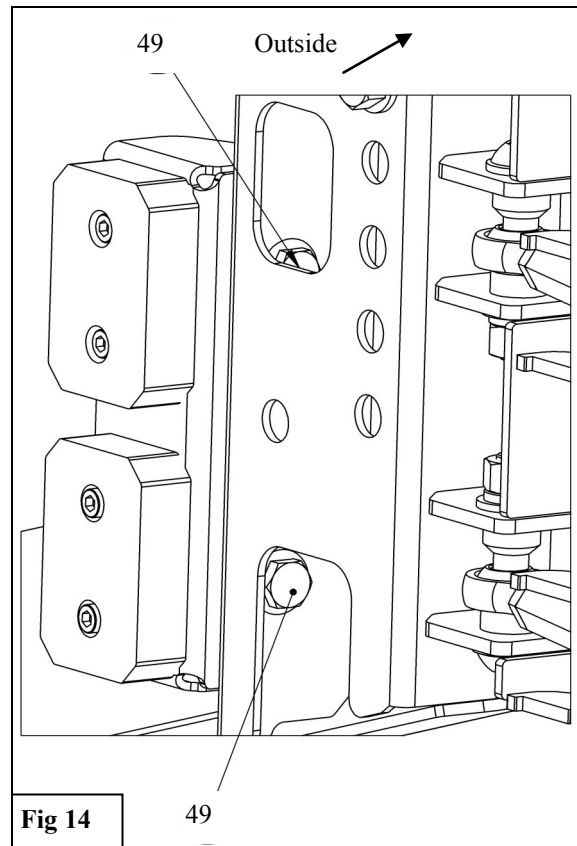
11. Install the Rubber Bumper (9) to the Rubber Bumper Bracket (8) using the supplied M6 Hardware. See Figures 12 and 13.
12. Install the Rubber Bumper Assembly to the Tire Carrier (2) using the supplied M10 Hardware. See Figures 13 and 14.



**Fig 12**

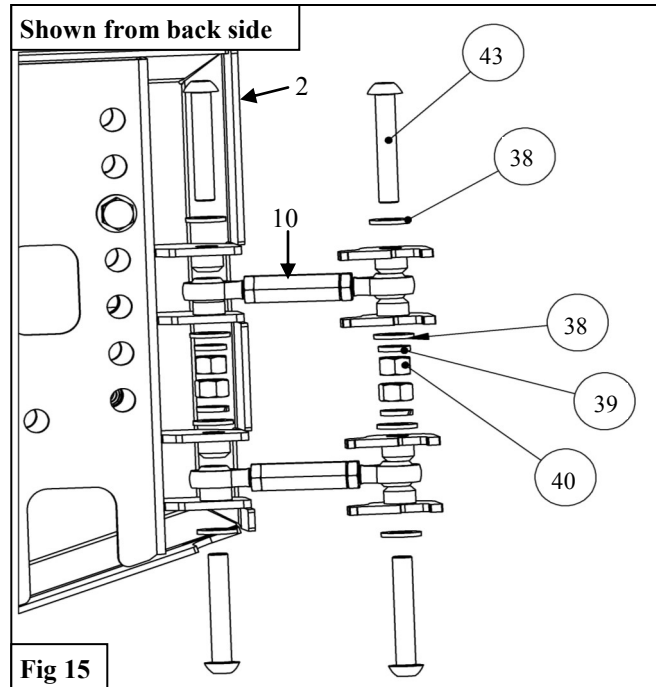


**Fig 13**

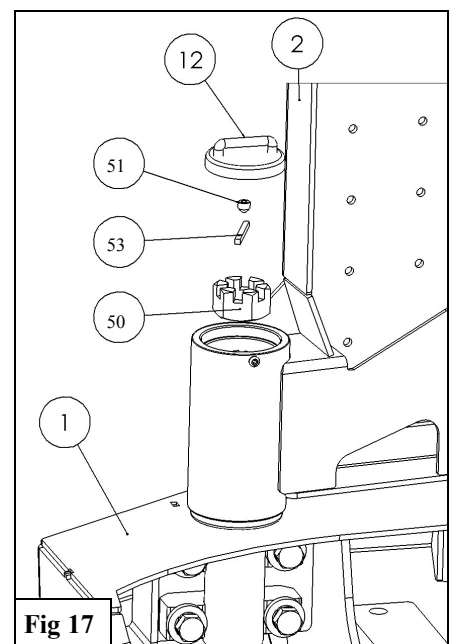
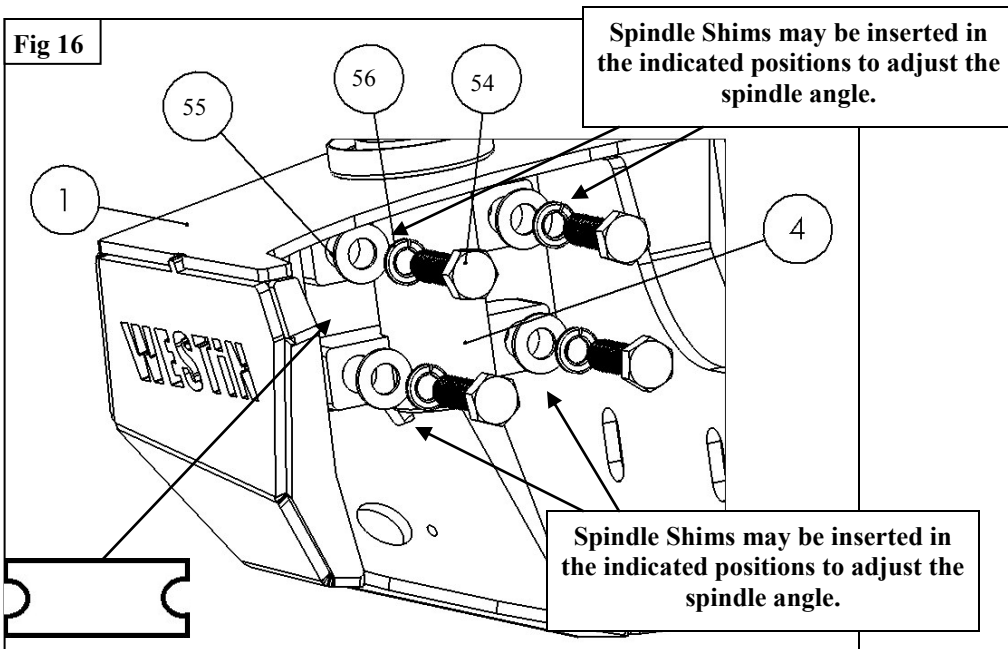


**Fig 14**

15. Lift the Tire Carrier Assembly and carefully slide it onto the Spindle (4).
16. Install the M24 Castle Nut (50) onto the Spindle (4). You may now tighten the Castle Nut (50) just until tension is felt. Then, place the 4mm Keystock (53) in the slot on the Castle Nut (50) and Spindle (4).
17. Loosely install the Turn Buckles (10) at this time. **See Figure 15.**
18. Adjust the Tire Carrier so that it sits just above level with the tub of the vehicle. With help, torque the M12 Spindle hardware to **75-78 ft-lb.**  
*Note: If the tire carrier is not vertical, use the supplied Spindle Shims (42) to change the angle of the spindle with the tub of the vehicle. See Figure 16.*

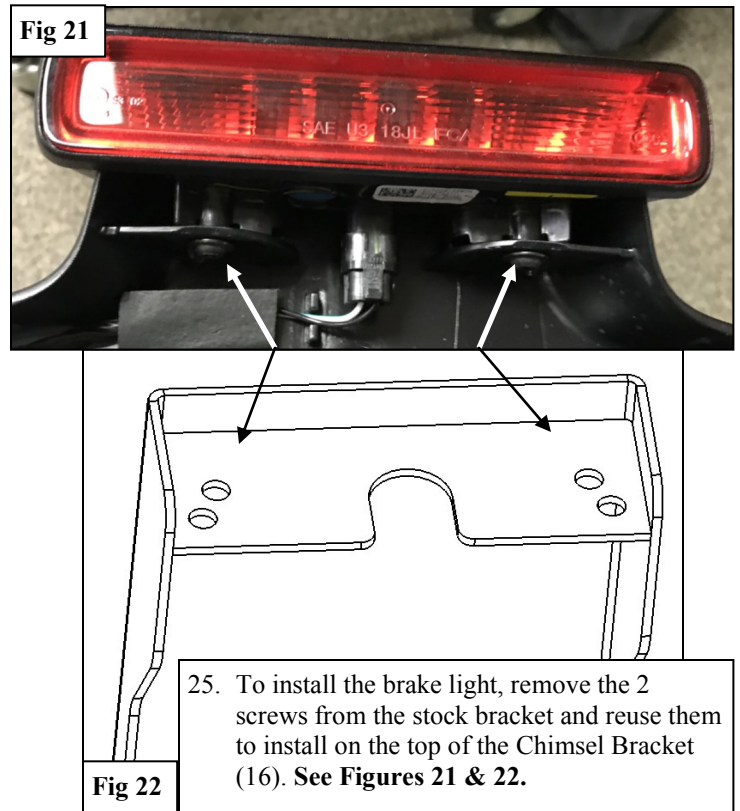
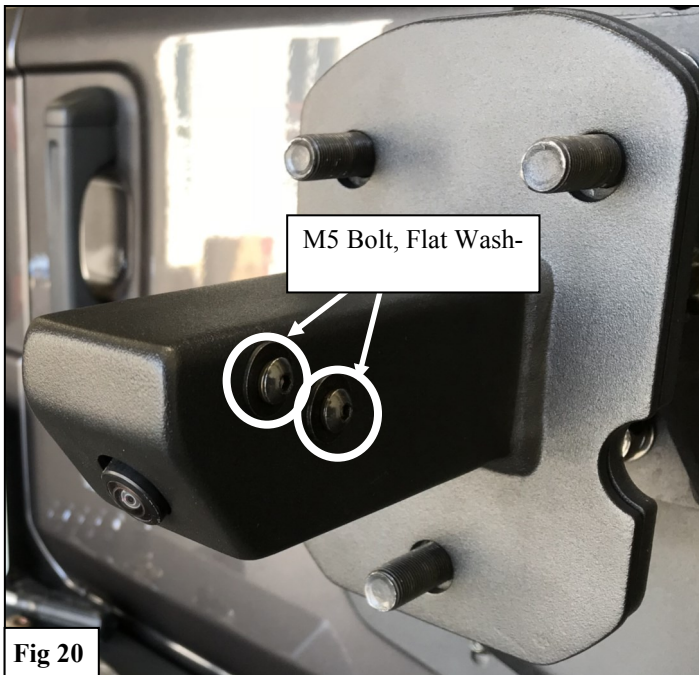
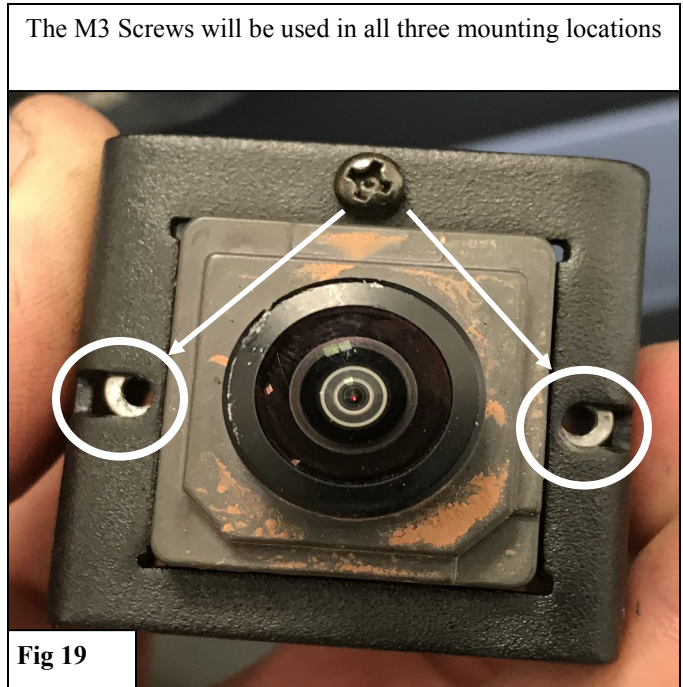


19. Tighten the Turn Buckles (10) until the Rubber Bumpers (9) come in contact with the Tailgate Mount (6). *Note— some trimming of the Rubber Bumpers may be required if they contact the bolts on the Tailgate Mount.*
20. Tighten the jam nuts on the Turn Buckles (10).
21. Secure the Castle Nut (50) with the supplied M8 Set Screw (51). **See Figure 17.**





22. Before mounting the rear view camera, use the supplied Corrugated Sleeve (18) to wrap the areas of the wire inside the tire carrier. **See Figure 18.**
23. Obtain the Camera Mounting Bracket (17) and attach the camera using the supplied M3 Screws (32). **See Figure 19.**
24. Slide the camera into the Camera Extension Bracket (17) and secure it using the supplied M5 Hardware. **See Figure 20.**  
*Note: There is a small amount of adjustment for the camera by loosening the bolts and adjusting using the access hole on the underside of the Extension (17).*





## INSTALLATION COMPLETE



### CARE INSTRUCTIONS

- REGULAR WAXING IS RECOMMENDED. DO NOT USE ANY TYPE OF POLISH OR WAX THAT MAY CONTAIN ABRASIVES
- STAINLESS STEEL PRODUCTS CAN BE CLEANED WITH MILD SOAP AND WATER. STAINLESS STEEL POLISH SHOULD BE USED TO POLISH SMALL SCRATCHES.
- GLOSS BLACK FINISHES SHOULD BE CLEANED WITH MILD SOAP AND WATER

**WESTIN**