

INSTALLATION INSTRUCTIONS



**WJ2 Rear Bumper
WJ2 Rear Bumper w/ Tire Carrier**

APPLICATION:

2007-2018 Jeep Wrangler JK (Excl. 2018 JL)

PART NUMBER:

Complete Kit: 59-82015

Rear Bumper: 59-82015A

Tire Carrier Kit: 59-82015B

CONTENT			
ITEM	QUANTITY	DESCRIPTION	TOOLS NEEDED
1	1	REAR BUMPER ASSEMBLY	18MM SOCKET
2	1	TIRE CARRIER ASSEMBLY *59-82015B	18MM WRENCH
3	2	M12 NUT PLATE	36MM SOCKET
4	1	SPINDLE *59-82015B	10MM WRENCH
5	1	BEARING KIT *59-82015B	RATCHET
6	1	TAILGATE MOUNT *59-82015B	TORQUE WRENCH
7	1	TIRE MOUNT ASSEMBLY *59-82015B	ALLEN WRENCH
8	1	RUBBER BUMPER BRACKET *59-82015B	DRILL MOTOR
9	2	RUBBER BUMPER *59-82015B	1/2" DRILL BIT
10	2	TURN BUCKLE ASSEMBLY *59-82015B	15MM SOCKET
11	4	SPACER WASHER	
12	1	BEARING CAP *59-82015B	
13	8	M12 HEX HEAD CAP SCREW; (2) 20MM *59-82015B , (4) 35MM, (2) 90MM *59-82015B (BLACK ZINC)	
14	6	M12 2.5MM THICK FLAT WASHER (BLACK ZINC)	
15	12	M12 SPLIT LOCK WASHER (BLACK ZINC)	
16	2	M12 SHORT BUTTON HEAD BOLT (BLACK ZINC)	
17	4	M4 BUTTON HEAD SCREW (BLACK ZINC)	
18	4	M4 FLAT WASHER (BLACK ZINC)	
19	4	M4 SPLIT LOCK WASHER (BLACK ZINC)	
20	4	M4 HEX NUT (BLACK ZINC)	

Note: The Bumper (59-82015A) and Tire Carrier Assembly(59-82015B) are packaged in different boxes. This install sheet is included in both packages for your convenience.



CONTENT

ITEM	QUANTITY	DESCRIPTION
21	4	M12 LONG BUTTON HEAD BOLT *59-82015B (BLACK ZINC)
22	16	M12 2MM THICK FLAT WASHER *59-82015B (BLACK ZINC)
23	6	M12 HEX NUT *59-82015B (BLACK ZINC)
24	2	M12 FULL THREAD CAP SCREW *59-82015B (BLACK ZINC)
25	2	M12 NYLON LOCK NUT *59-82015B (BLACK ZINC)
26	2	M10 HEX HEAD BOLT *59-82015B (BLACK ZINC)
27	2	M10 HEX FLANGE NUT *59-82015B (BLACK ZINC)
28	8	M8 BUTTON HEAD BOLT *59-82015B (BLACK ZINC)
29	8	M8 FLAT WASHER *59-82015B (BLACK ZINC)
30	8	M8 SPLIT LOCK WASHER *59-82015B (BLACK ZINC)
31	1	M8 SET SCREW *59-82015B (BLACK ZINC)
32	4	M6 HEX SOCKET HEX SCREW *59-82015B (BLACK ZINC)
33	8	M6 FLAT WASHER *59-82015B (BLACK ZINC)
34	4	M6 NYLON LOCK NUT *59-82015B (BLACK ZINC)
35	4	M12 HEX HEAD CAP SCREW 60MM CLASS 10.9 *59-82015B (BLACK ZINC)
36	4	M12 HEAVY WASHER *59-82015B (YELLOW ZINC)
37	4	M12 HARDENED SPLIT LOCK WASHER *59-82015B (YELLOW ZINC)
38	1	M4 PHILLIPS SCREW *59-82015B (BLACK ZINC)
39	1	M24 CASTLE NUT *59-82015B (BLACK ZINC)
40	1	4MM SQUARE KEYSTOCK *59-82015B
41	4	SPINDLE SHIMS *59-82015B

ANTI-SEIZE LUBRICANT MUST BE USED ON ALL STAINLESS STEEL FASTENERS TO PREVENT THREAD DAMAGE AND GALLING

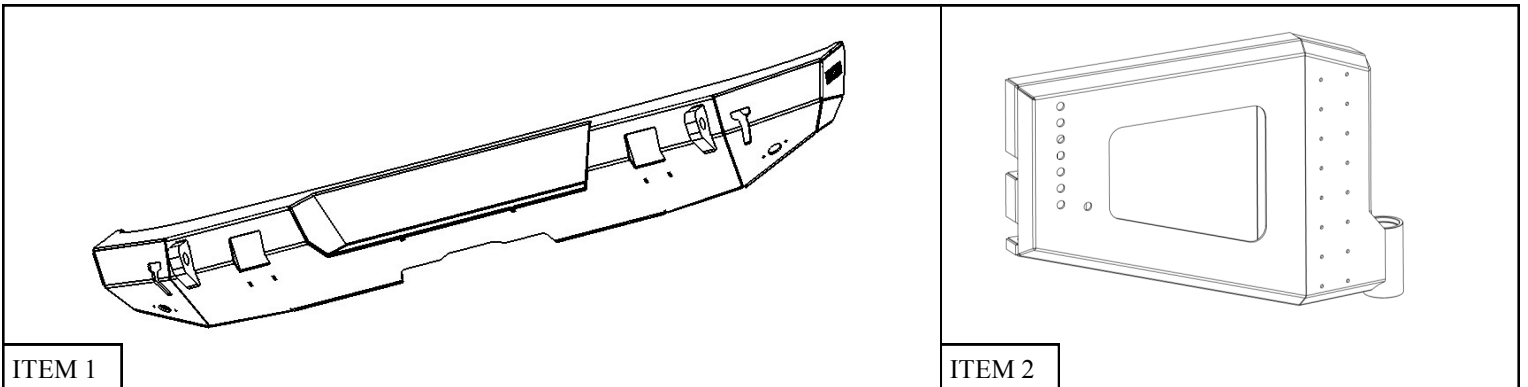

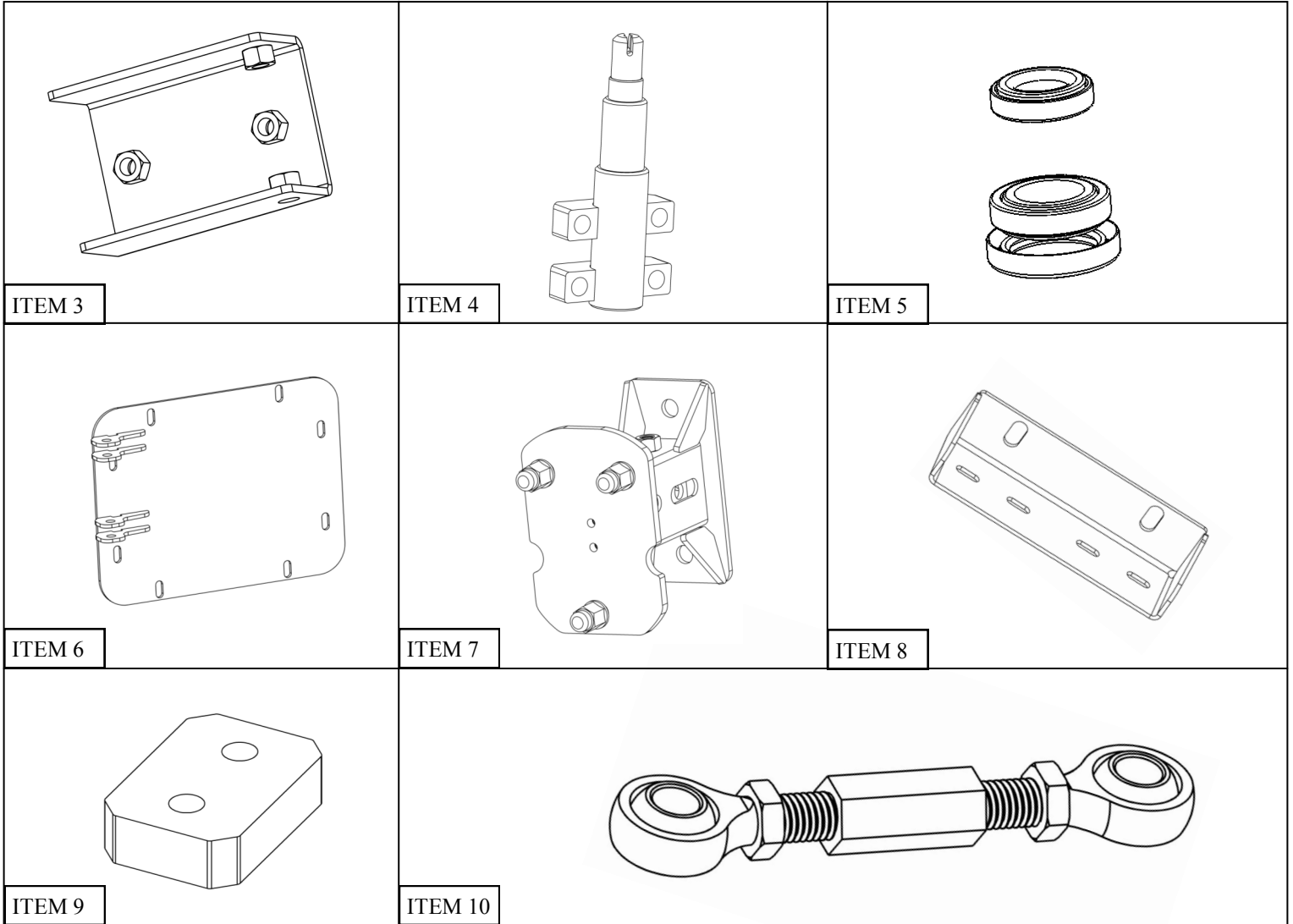

PROCEDURE

1. Remove contents from box, verify if all parts listed are present and free from damage.
Carefully read and understand all instructions before attempting installation.
Failure to identify damage before installation could lead to a rejection of any claim.

2. Remove Stock Bumper

- a. Disconnect all electrical connections to the rear bumper.
- b. Remove the two bolts holding the stock frame brackets to the frame on each side of the vehicle. See **Figure 1**.
- c. Remove the two brackets that attach the rear cross member to the bumper.
- d. Remove the recovery hook from each side of the vehicle by removing the two bolts on each side. See **Figure 1**.
- e. Remove the bracket and bolt indicated in **Figure 1** from each side of the vehicle.

Note 1: Stock recovery hooks and brackets will not be reused.

Note 2: WJ2 Rear Bumper will work with or without the factory hitch.

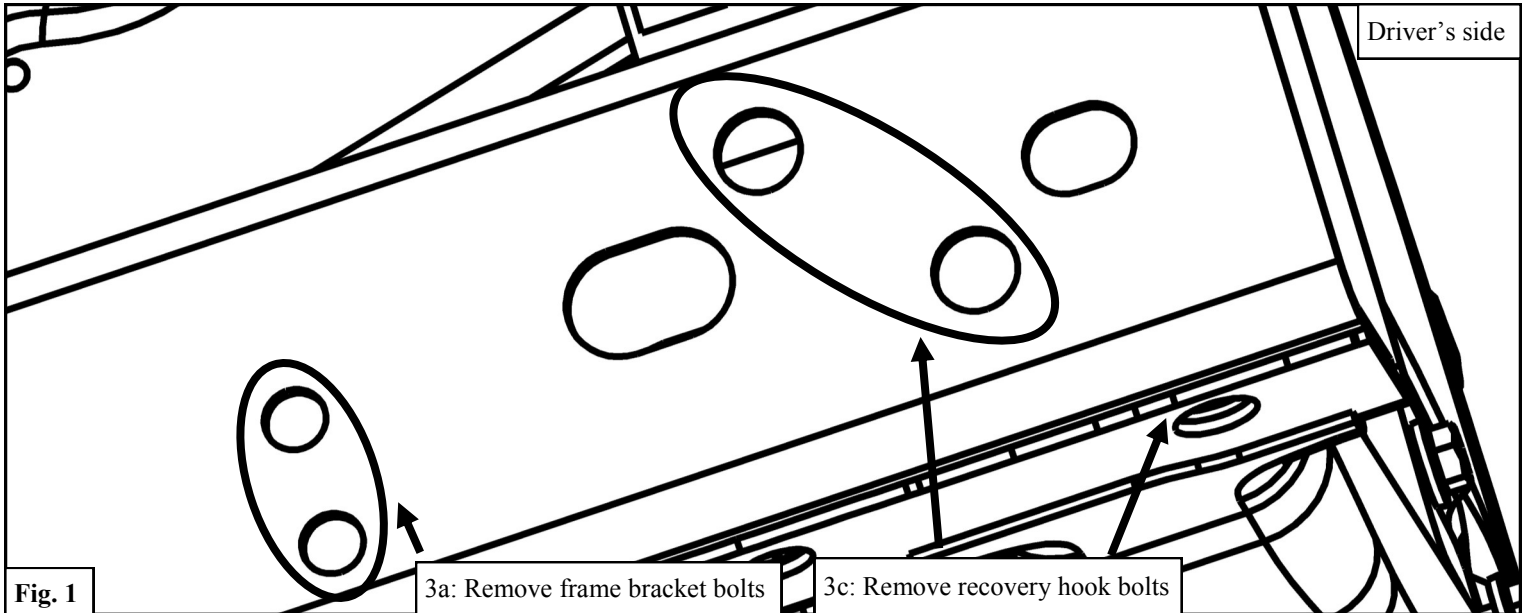

3. Install the spindle (4) onto the bumper using the supplied M12 Hardware. See **Figure 2**. *Note— do not fully tighten at this time.* *This step is only taken for 59-82015 **Important: Use the Class 10.9 Hardware & thick washers to mount the spindle.**

IT IS IMPORTANT TO USE
THE CLASS 10.9
HARDWARE

Class 10.9

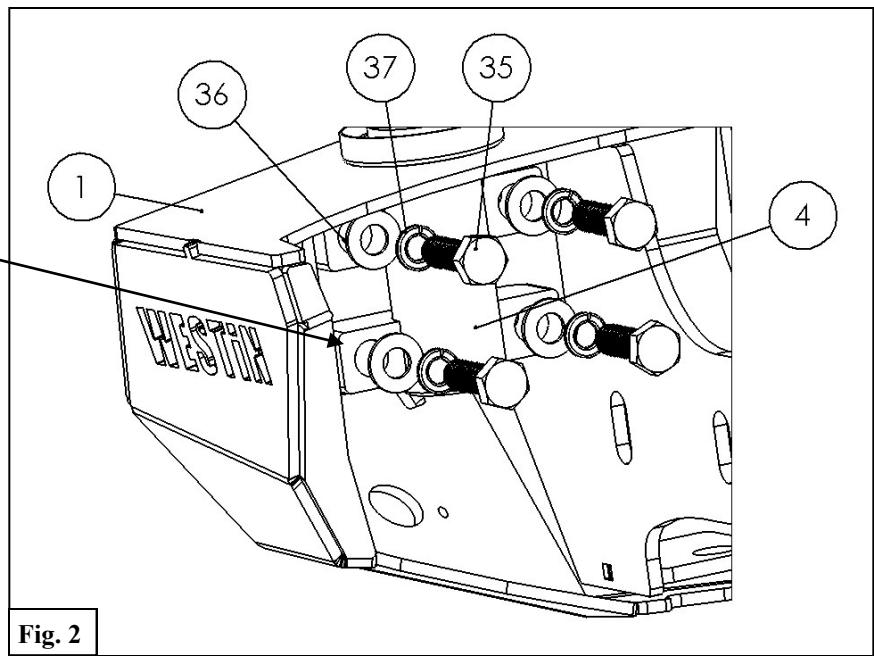

- Slide the nut plates (3) into the back of the frame on each side of the vehicle as shown in **Figure 3**.
- Position the rear bumper assembly (1) as shown in **Figure 4**. *Note: The holes on the sides and bottom of the bumper should line up with the corresponding nuts on the nut plate.*

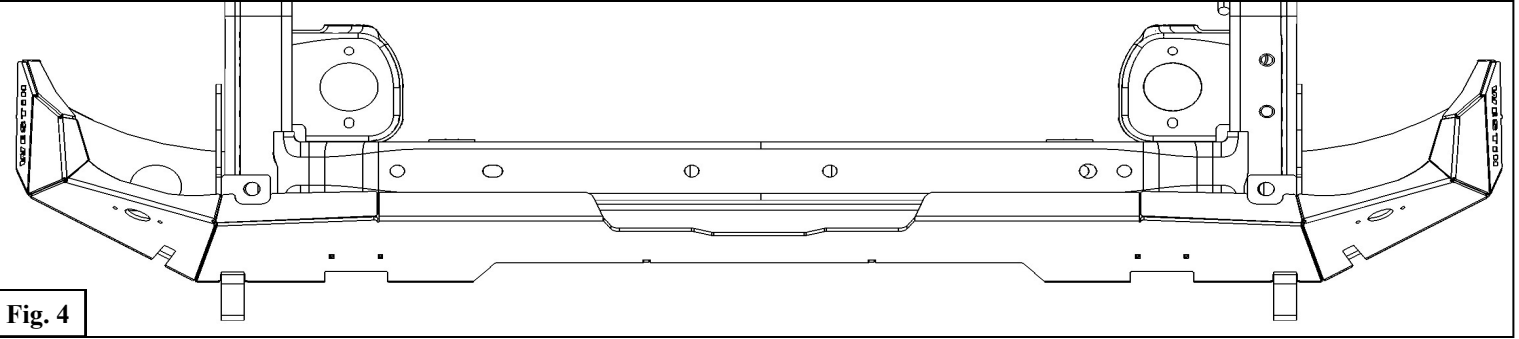
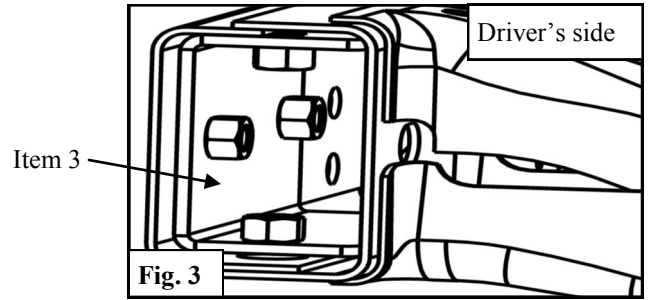

Fig. 4

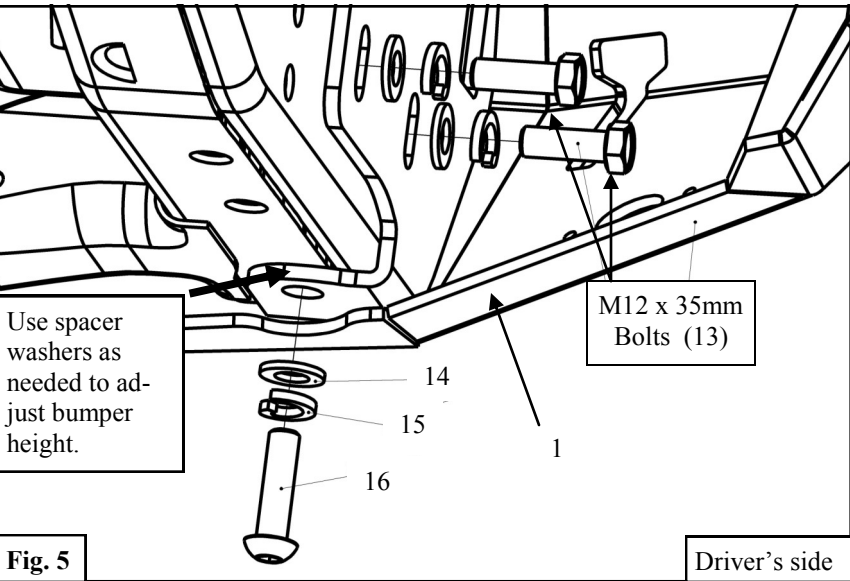

Fig. 5

- Install the rear bumper assembly (1) with the supplied M12 hardware according to **Figure 5**. *Note: Spacer washers can be used as needed to fill the gap between the bottom of the frame and the rear bumper. This allows vertical adjustment of the bumper.*
- Tighten M12 hardware to 50-55 ft-lbs.

Note: If there is no hole present in the frame rail for the bottom two bolts, you must drill a 1/2" hole in the frame to accept the M12 hardware.

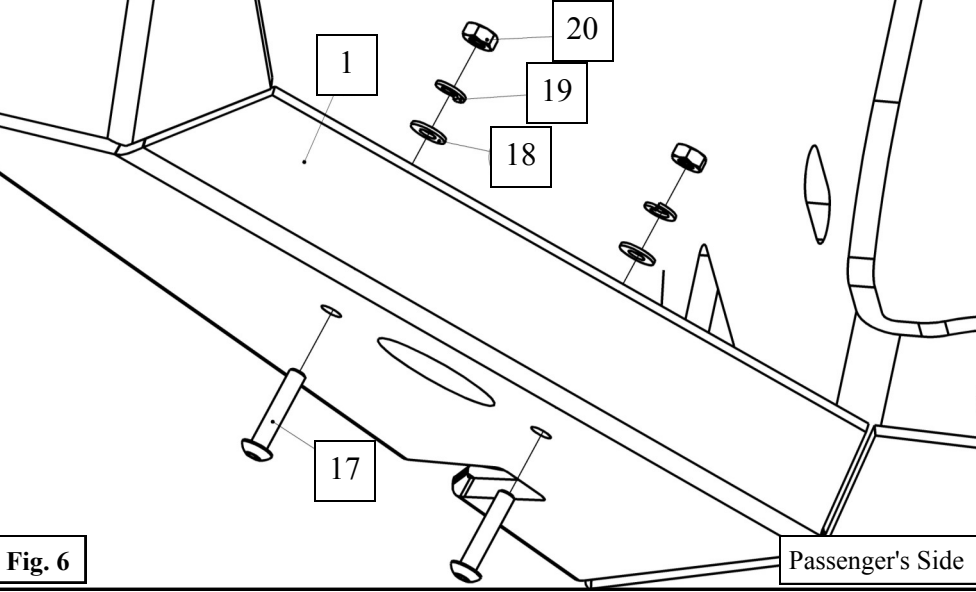

Fig. 6

Optional Step:
 Lights (sold separately) can be installed in the lower corners of the bumper using the supplied M4 hardware. *Note: Install lights per manufacturers instructions. See **Figure 6**.*

TIRE CARRIER INSTALLATION

8. Remove the bolts securing the factory tire carrier to the tailgate. See **Figure 7**.
9. Remove the vent at this time as well.

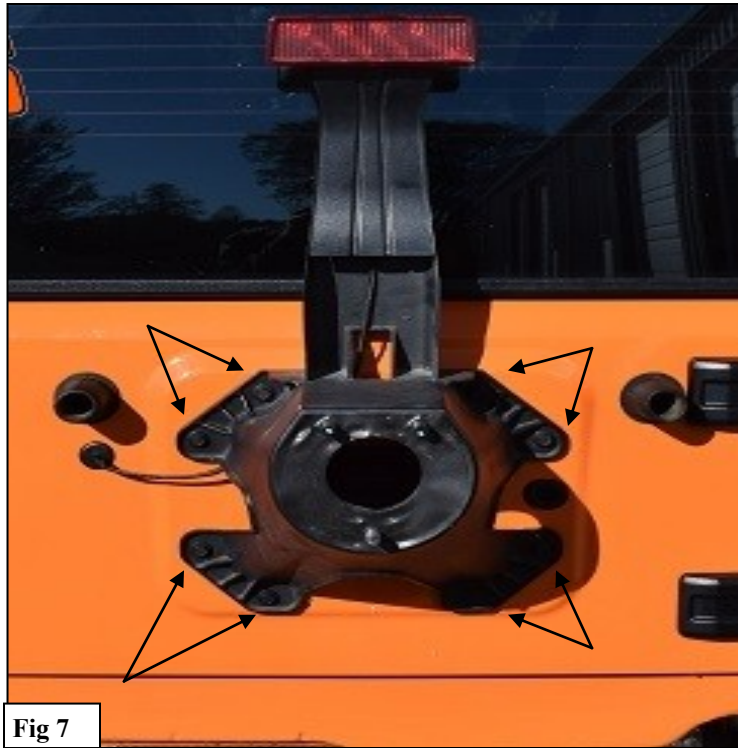

Fig 7

10. Install the Tailgate Mount (6) on the vehicle using the supplied M8 Hardware. See **Figure 8**. *Note:* The vertical slots allow adjustment when aligning the tire carrier gate.

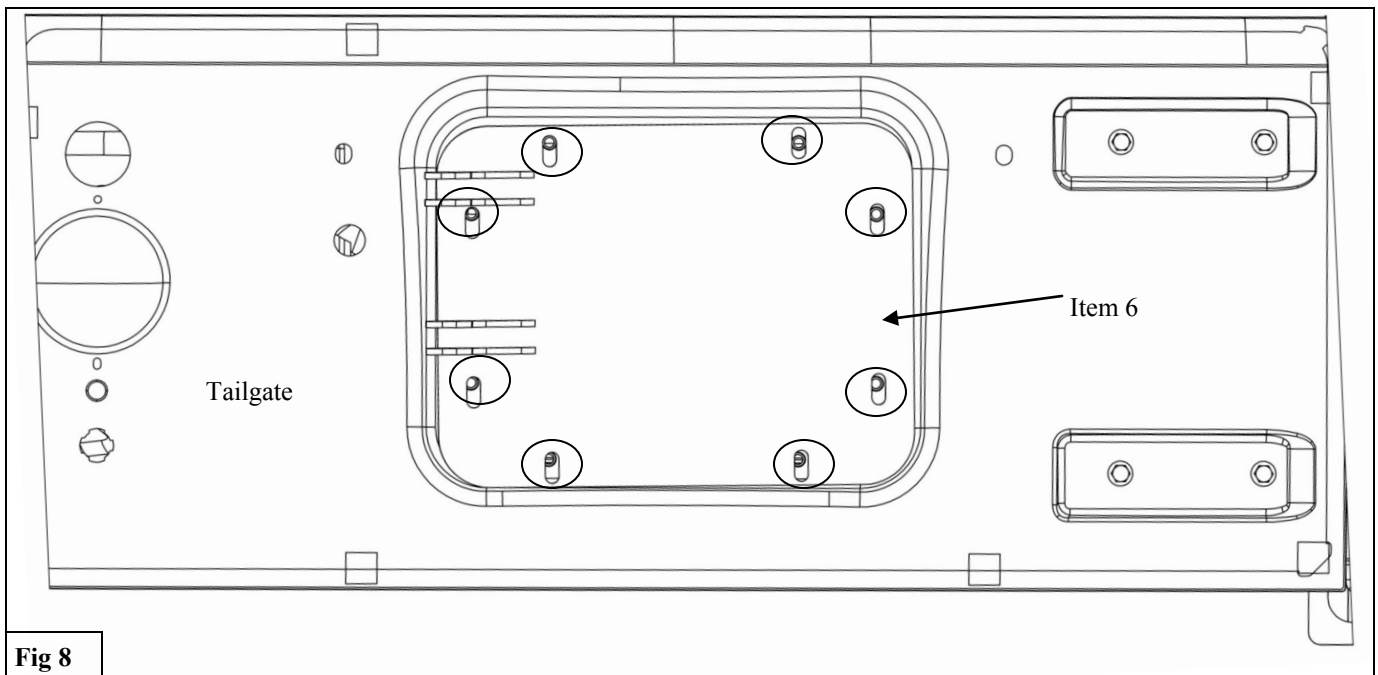

Fig 8

11. Bearing Installation

- A. Obtain the Bearing Kit (5).
- B. Identify the large bearing, race, and seal.
- C. Turn the Tire Carrier over so that the bottom of the spindle tube is facing up.
- D. Insert the bearing race into the tube with the tapered side facing up. **See Figure 9.**
- E. Place a generous amount of grease (not included) in the palm of your hand, and tap the bearing repeatedly in the grease until grease is spread throughout the rollers in the bearing.
- F. Place the bearing into the race as oriented in **Figure 9.**
- G. Place the large bearing washer on top of the bearing. **See Figure 9.**
- H. Using a soft hammer, tap the seal into place until flush with the bottom of the spindle tube on the tire carrier. **See Figure 9.**
- I. Repeat steps B-G for the small bearing with the tire carrier turned right side up.

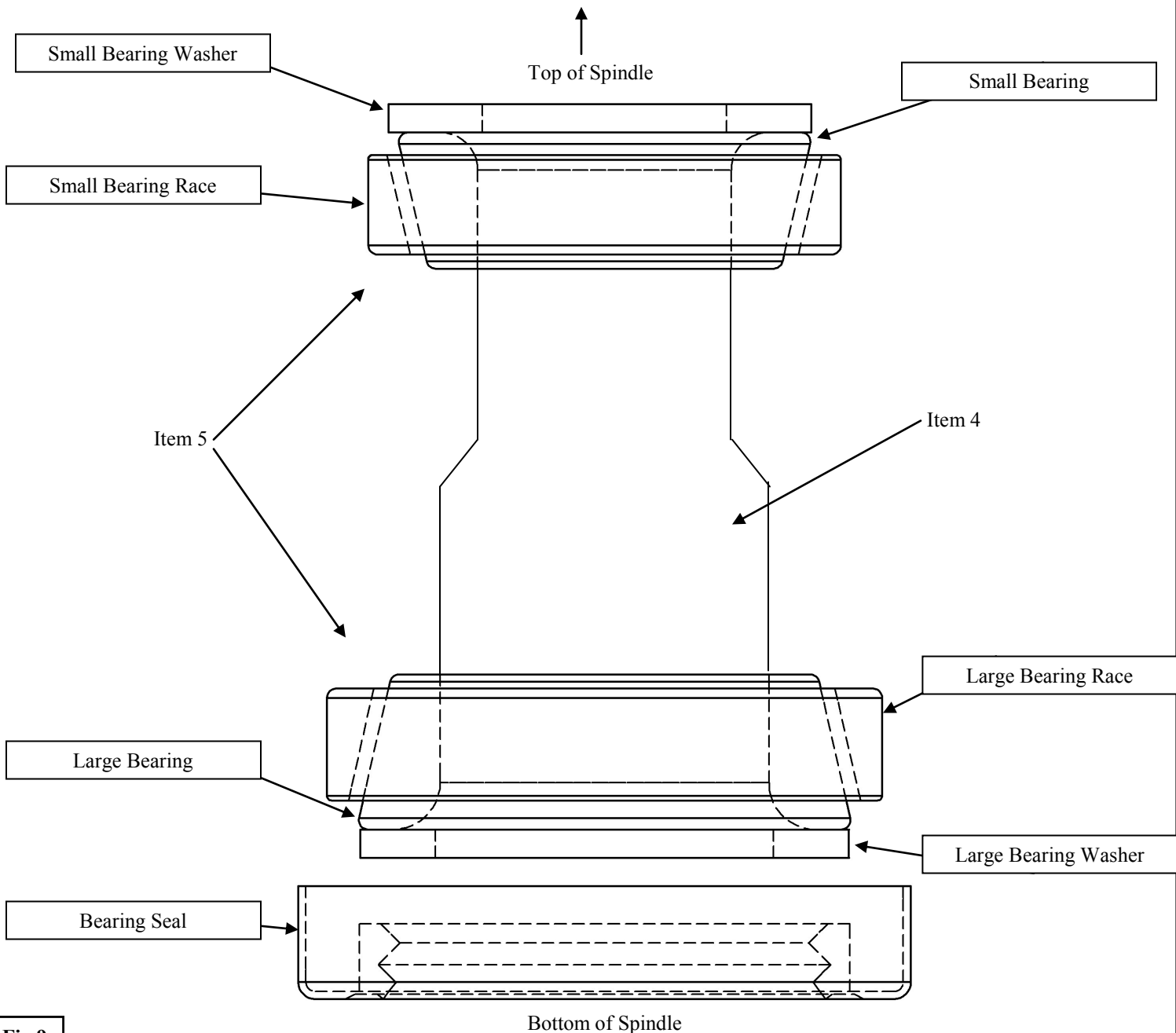
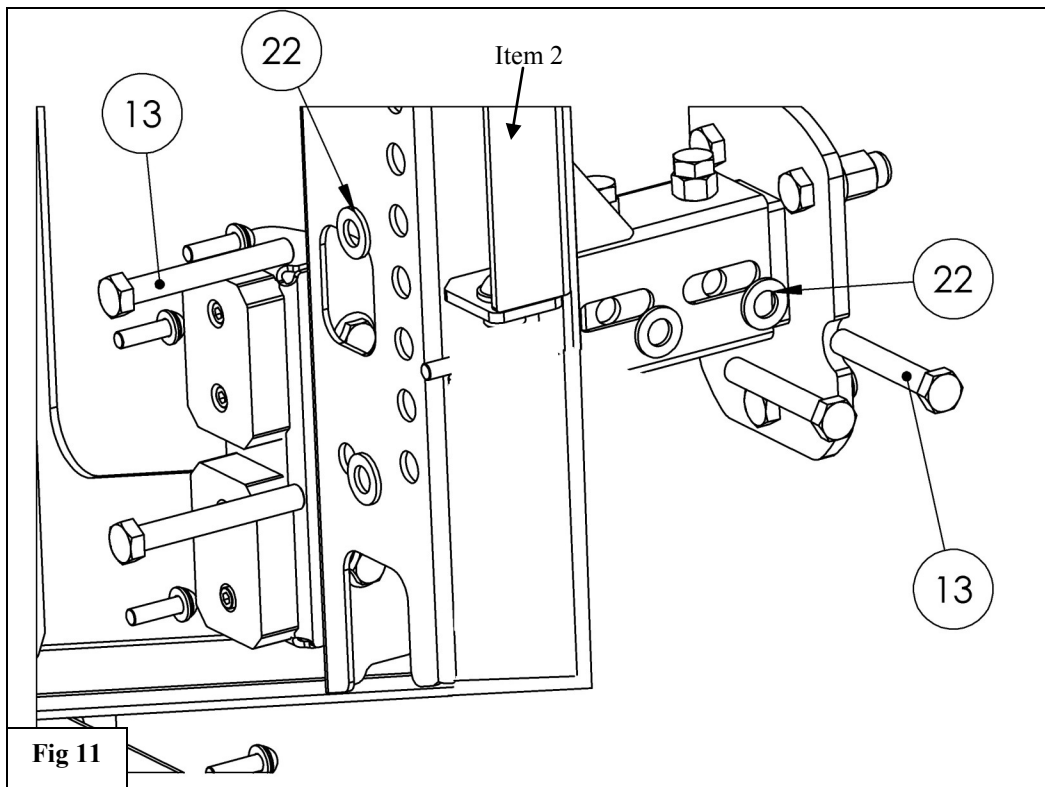
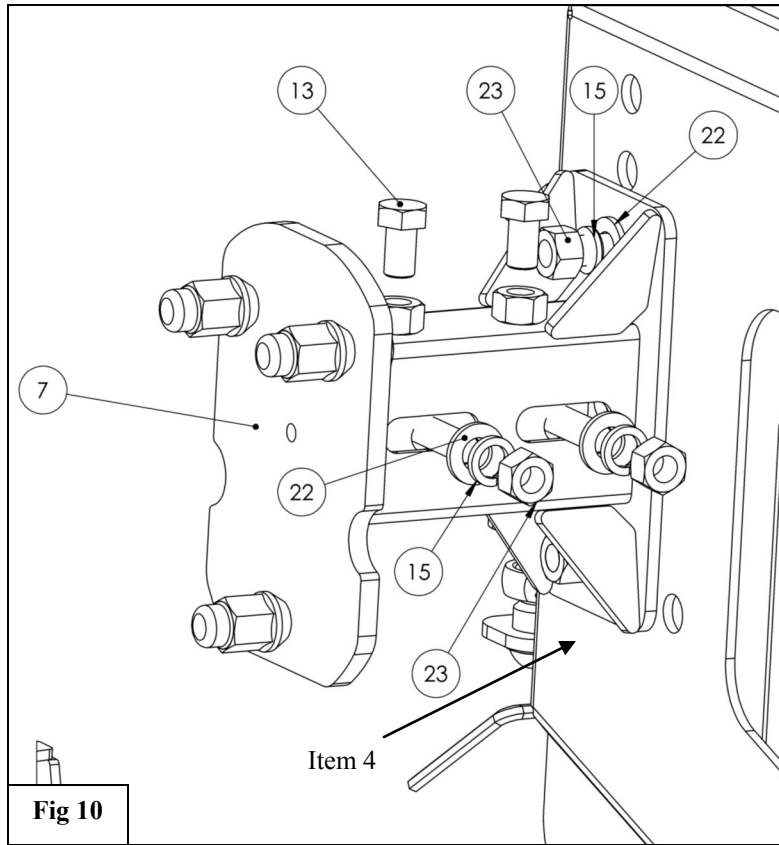

Fig 9

TIRE CARRIER ASSEMBLY

12. Install the Tire Mount Assembly (7) to the tire carrier using the supplied M12 Hardware. See Figures 10 and 11.



13. Install the Rubber Bumper (9) to the Rubber Bumper Bracket (8) using the supplied M6 Hardware. See Figures 12 and 13.
 14. Install the Rubber Bumper Assembly to the Tire Carrier (2) using the supplied M10 Hardware. See Figures 13 and 14.

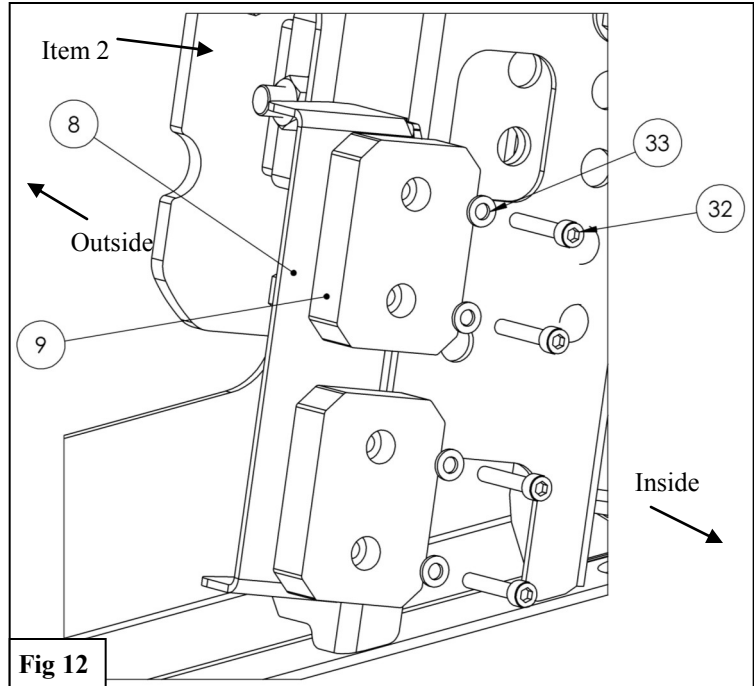
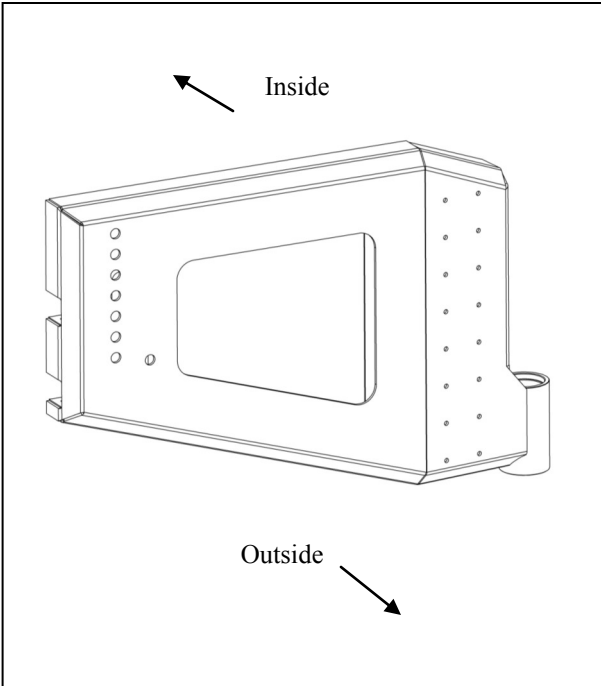

Fig 12

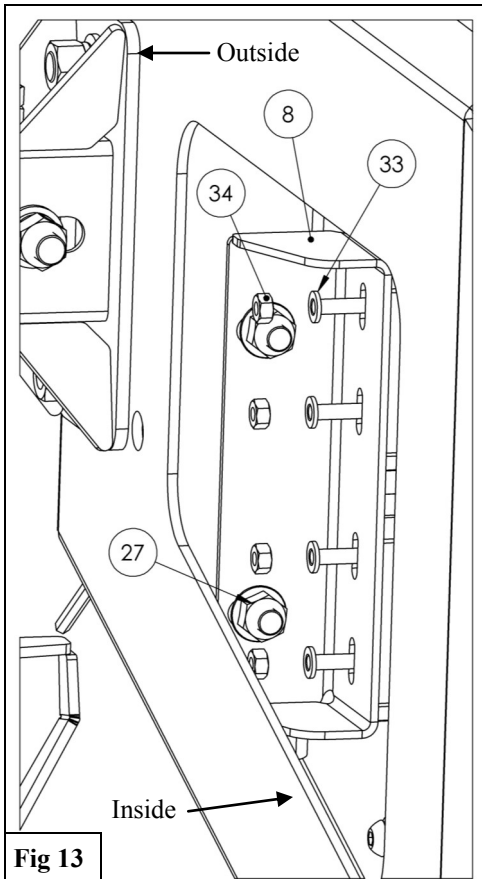

Fig 13

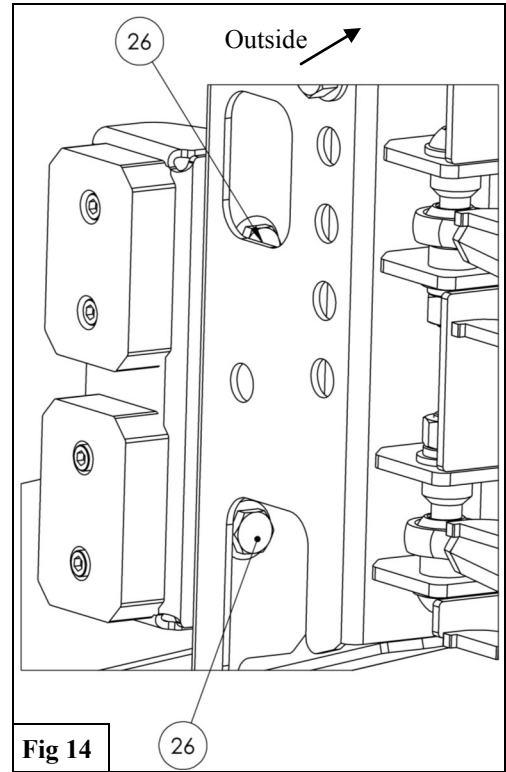
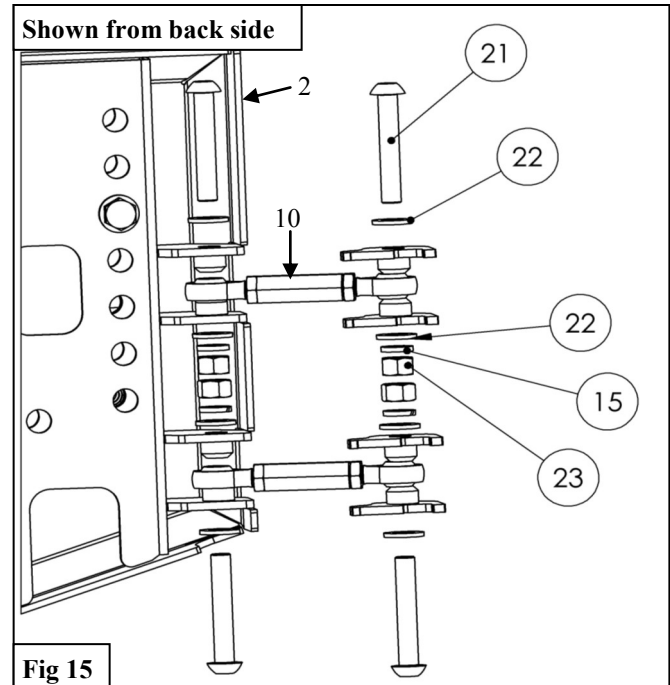
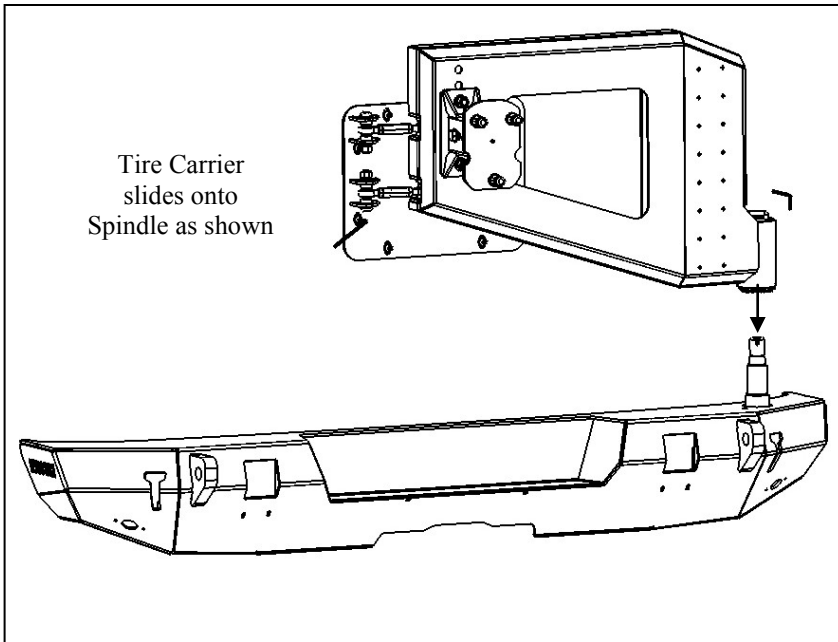
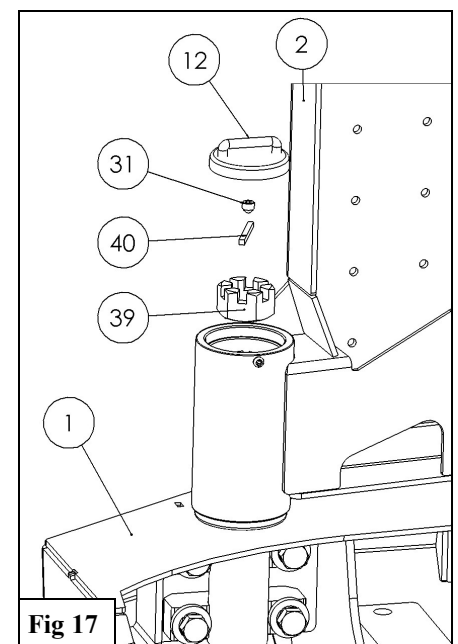
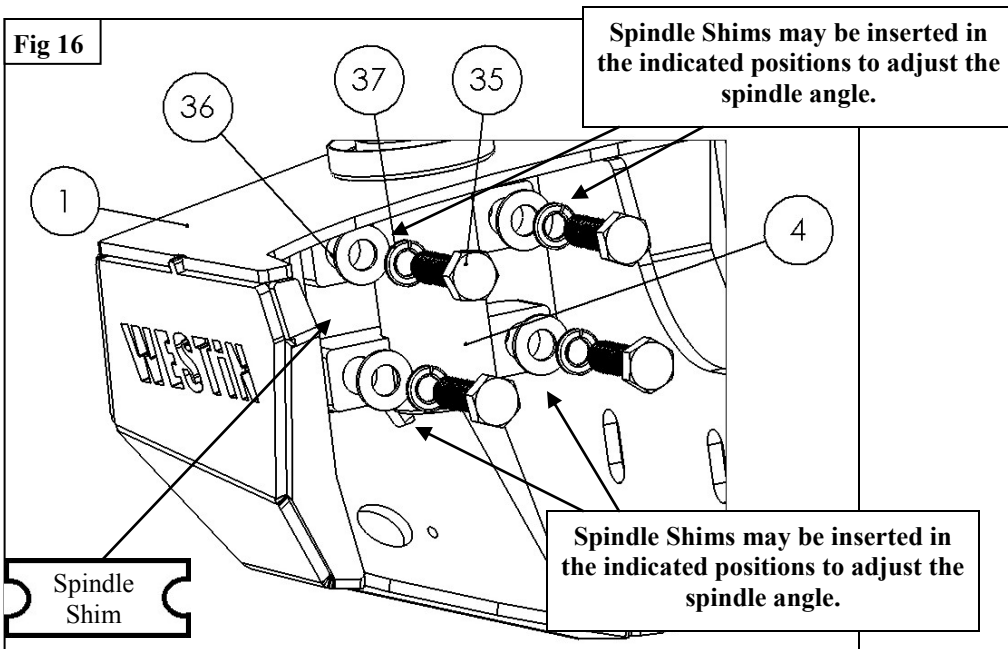

Fig 14

15. Lift the Tire Carrier Assembly and carefully slide it onto the Spindle (4).
16. Install the M24 Castle Nut (39) onto the Spindle (4). You may now tighten the Castle Nut (39) just until tension is felt. Then, place the 4mm Keystock (40) in the slot on the Castle Nut (39) and Spindle (4).
17. Loosely install the Turn Buckles (10) at this time. **See Figure 15.**
18. Adjust the Tire Carrier so that it sits just above level with the tub of the vehicle. With help, torque the M12 Spindle hardware to **75-78 ft-lb.**
Note: If the tire carrier is not vertical, use the supplied Spindle Shims (41) to change the angle of the spindle with the tub of the vehicle. See Figure 16.



19. Tighten the Turn Buckles (10) until the Rubber Bumpers (9) come in contact with the Tailgate Mount (6). *Note— some trimming of the Rubber Bumpers may be required if they contact the bolts on the Tailgate Mount.*
20. Tighten the jam nuts on the Turn Buckles (10).
21. Secure the Castle Nut (39) with the supplied M8 Set Screw (31). **See Figure 17.**



INSTALLATION COMPLETE





WARNING



Failure to follow these instructions could lead to death, personal injury, and / or property damage.

Failure to follow these instructions could lead to death, personal injury, and / or property damage.

FASTENERS:

All Westin supplied fasteners must be utilized and installed in accordance with the installation instructions and apply torque to the specifications as defined. **DOUBLE CHECK ALL FASTENERS BEFORE INITIAL USE, AND PERIODICALLY IN THE FUTURE TO ENSURE PROPER FUNCTION AND SAFETY.**

DRILLING:

Most Westin products do not require drilling for installation. If drilling is defined as required, use caution when drilling a vehicle. **FAILURE TO REVIEW AN AREA TO BE DRILLED MAY RESULT IN PERSONAL INJURY AND/OR INJURY TO OTHERS AS WELL AS VEHICLE DAMAGE.**

EYE PROTECTION:

ALWAYS WEAR SAFETY GLASSES OR GOGGLES DURING THE INSTALLATION PROCESS TO AVOID PERSONAL INJURY.

MAXIMUM TOWING/CARRYING CAPACITY: (if applicable)

The Westin Receiver Hitches will have a visible tow rating label affixed directly on the product. User should never exceed the vehicle manufacturers maximum tow and weight rating regardless of the capacity of the hitch. **FAILURE TO FOLLOW THESE GUIDELINES WILL VOID THE WESTIN WARRANTY AND MAY RESULT IN PERSONAL INJURY AND/OR INJURY TO OTHERS AS WELL AS VEHICLE DAMAGE.**

FOR CALIFORNIA RESIDENTS ONLY-PROP 65 WARNING:

Some products may contain chemicals such as DEHP, which can cause cancer, birth defects or other reproductive harm.

