

INSTALLATION INSTRUCTIONS

WJ2 FULL-WIDTH FRONT BUMPER

APPLICATION:

2018 Jeep Wrangler JL PART

NUMBER:

59-80105, 59-80115, 59-80125



CONTENT			
ITEM	QUANTITY	DESCRIPTION	TOOLS NEEDED
1	1	FRONT BUMPER ASSEMBLY	7MM SOCKET
2	2	LED MOUNTING BRACKET *59-80125 only	7MM WRENCH
3	8	M10 FLAT WASHER	10MM SOCKET
4	8	M10 SPLIT LOCK WASHER	10MM WRENCH
5	4	M10 HEX HEAD CAP SCREW	13MM SOCKET
6	4	M10 HEX NUT	13MM WRENCH
7	4	M6 SERRATED FLANGE NUT * ONLY INCLUDED WITH 59-80125	16MM SOCKET
8	4	M6 SOCKET BUTTON HEAD BOLT *ONLY INCLUDED WITH 59-80125	16MM WRENCH
9	4	M6 NYLOCK NUT	ALLEN WRENCH
10	4	SMALL M6 FLAT WASHER	RATCHET
11	4	M4 HEX NUT	TORQUE WRENCH
12	12	M4 FLAT WASHER	DRILL
13	4	M4 SPLIT LOCK WASHER	
14	4	SHORT M4 HEX SOCKET BUTTON HEAD SCREW	
15	2	LONG M4 HEX SOCKET BUTTON HEAD SCREW	
16	6	M4 HEX SOCKET CAP SCREW	
17	8	M4 NYLOCK NUT	
18	1	RUBBER GROMMET *ONLY INCLUDED WITH 59-80105 & 59-80115	
19	2	NYLON SPACER	
20	8	LARGE M4 FLAT WASHER	

ANTI-SEIZE LUBRICANT MUST BE USED ON ALL STAINLESS STEEL FASTENERS TO PREVENT THREAD DAMAGE AND GALLING

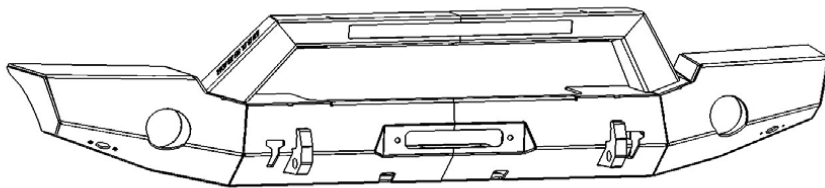

ITEM 1 (LED)

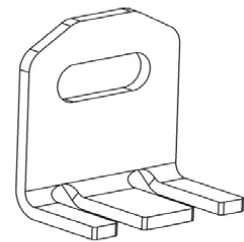

ITEM 2



PROCEDURE

1. Remove contents from box, verify if all parts listed are present and free from damage.
Carefully read and understand all instructions before attempting installation.
Failure to identify damage before installation could lead to a rejection of any claim.

2. Unplug any wire connections to the bumper such as fog lights.
3. Loosen the bolts securing the reinforcement brackets to the frame. See **Figure 1**.



4. Remove the 4 nuts on each frame horn that secure the bumper to the vehicle. See **Figures 2 & 3**.
5. Carefully remove the front bumper from the vehicle

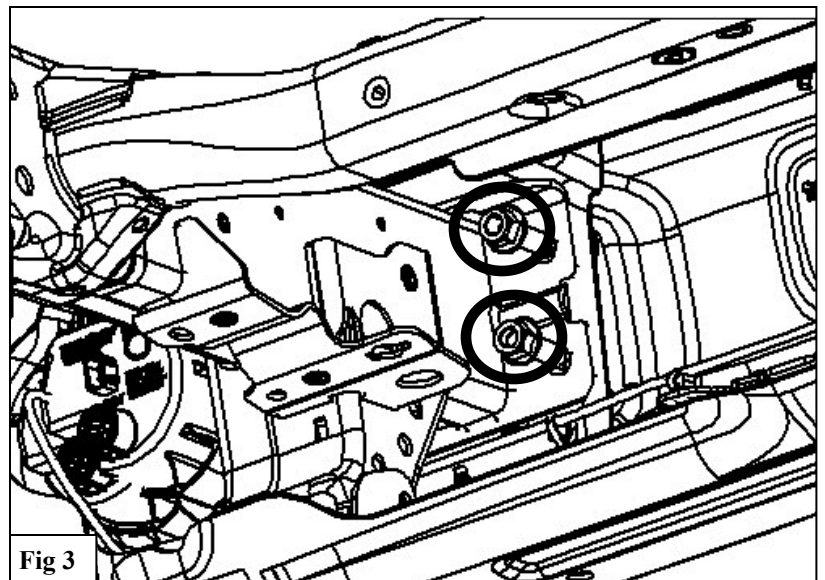
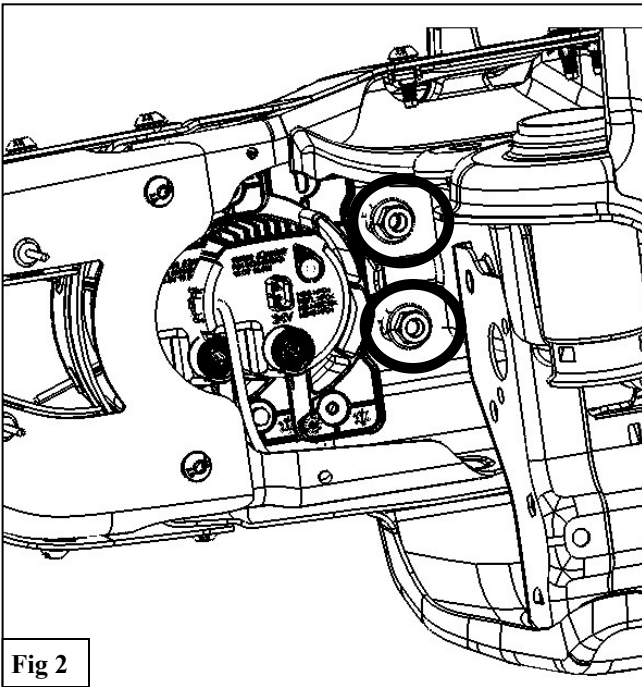

6. Align the Front Bumper Assembly (1) with the holes on the frame.
7. Use the supplied M10 Hardware (3-6) to secure the bumper to the vehicle. See Figures 4 & 5.

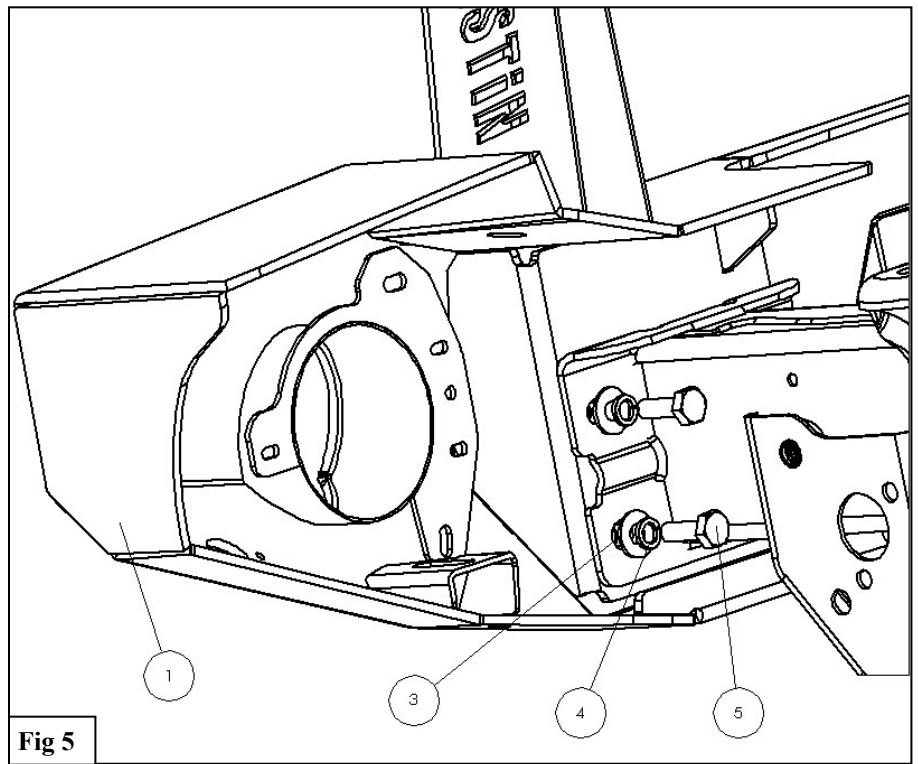
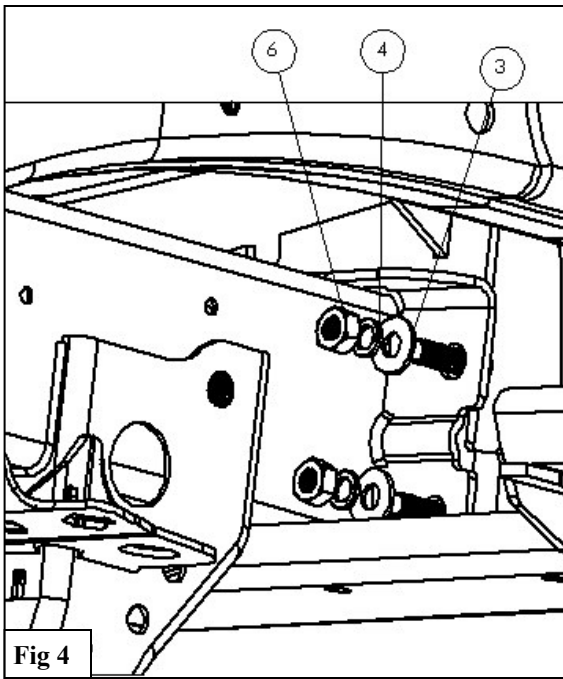

FOG LIGHT INSTALLATION (Full-width Bumper only)

Factory Fog Lights: OEM Steel Bumpers: Use the supplied M6 Flat Washer (10) and Nylock Nut (9) along with the factory hardware, secure the fog light to the bracket as shown in **Figure 1**.
OEM Plastic Bumpers: Use the supplied M4 hardware to secure the bracket to the bumper. See **Figure 2**. *Note: Light not shown.*
Aftermarket Lights: Use the universal mounting tab as **Figure 3** to secure the bracket to the bumper. See **Figure 2**. *Note: Lights sold separately.*

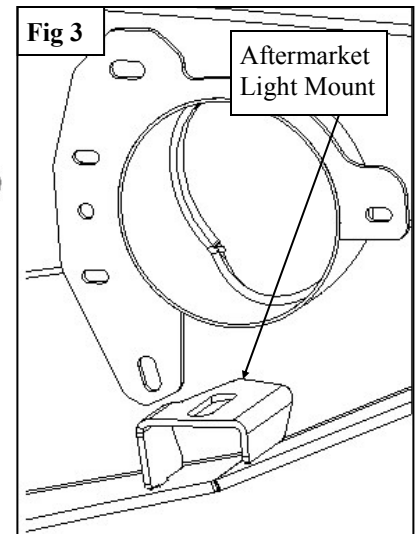
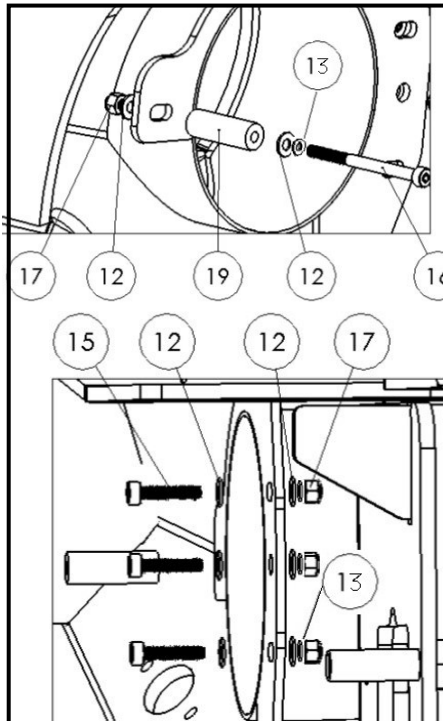
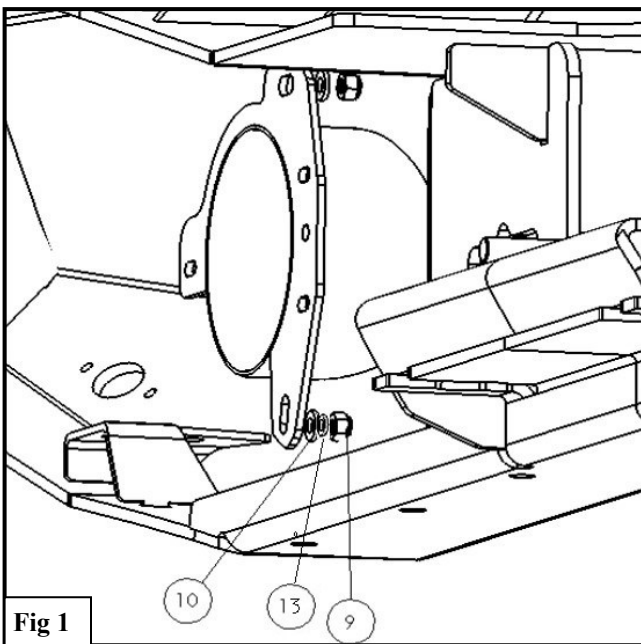

LED Light Mounting Instructions

Lights Sold Separately

20 Inch LED Light Bar Installation (59-80125 Only)

1. Loosely install the LED mounting tabs (2) to the front bumper assembly (1) using the supplied M6 hardware (7 & 8). See **Figure 1**. *Note:* The mounting tabs can be installed at a range of distances from one another in order to accommodate the width of the light bar. **Figure 2** shows the mounting tabs arranged in a wide configuration while **Figure 3** shows them arranged in a narrow configuration.
2. Install light bar according to manufacturer's instructions.
3. Tighten M6 hardware to 5-7 ft-lbs.

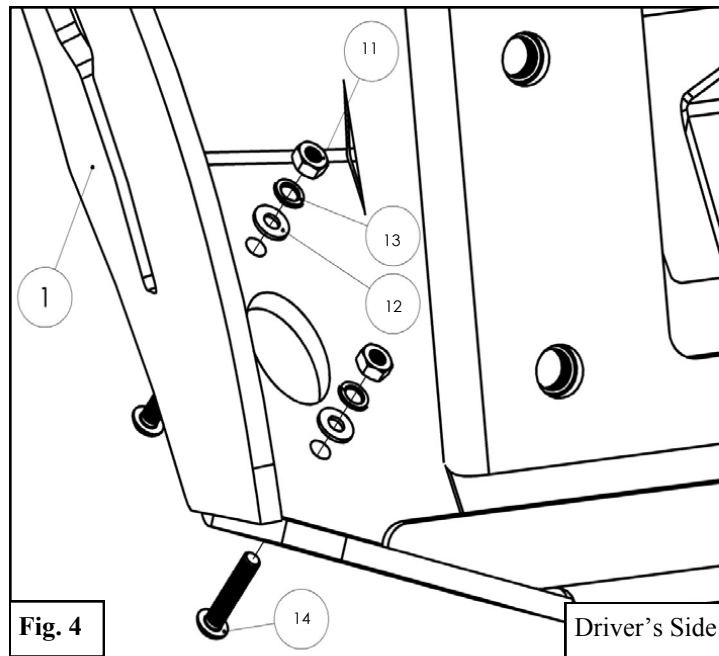
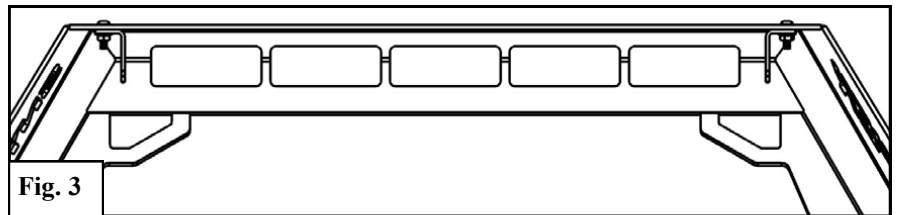
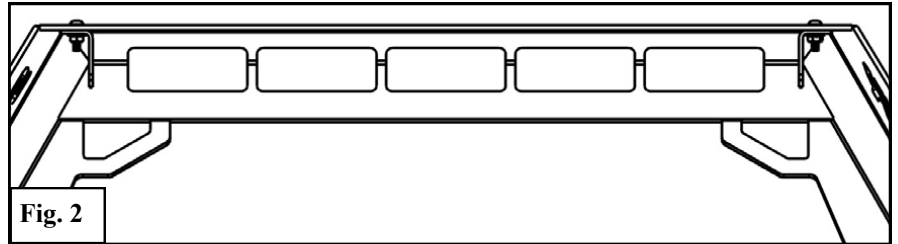
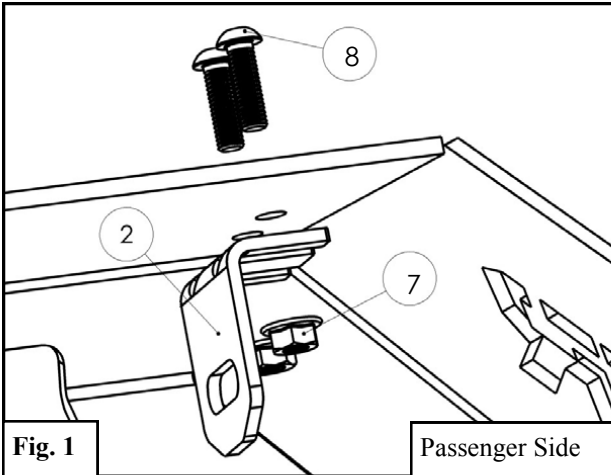

Rock Light Installation

Install lights in the lower corners of the bumper using supplied M4 hardware (11-14). See **Figure 4**.

Note: Wire lights per manufacturer's instructions.

Installation Complete (Lights, Winch, and Skidplate Sold Separately)



CARE INSTRUCTIONS

- REGULAR WAXING IS RECOMMENDED. DO NOT USE ANY TYPE OF POLISH OR WAX THAT MAY CONTAIN ABRASIVES
- STAINLESS STEEL PRODUCTS CAN BE CLEANED WITH MILD SOAP AND WATER. STAINLESS STEEL POLISH SHOULD BE USED TO POLISH SMALL SCRATCHES.
- GLOSS BLACK FINISHES SHOULD BE CLEANED WITH MILD SOAP AND WATER

WESTIN



WARNING



Failure to follow these instructions could lead to death, personal injury, and / or property damage.

Failure to follow these instructions could lead to death, personal injury, and / or property damage.

FASTENERS:

All Westin supplied fasteners must be utilized and installed in accordance with the installation instructions and apply torque to the specifications as defined. **DOUBLE CHECK ALL FASTENERS BEFORE INITIAL USE, AND PERIODICALLY IN THE FUTURE TO ENSURE PROPER FUNCTION AND SAFETY.**

DRILLING:

Most Westin products do not require drilling for installation. If drilling is defined as required, use caution when drilling a vehicle. **FAILURE TO REVIEW AN AREA TO BE DRILLED MAY RESULT IN PERSONAL INJURY AND/OR INJURY TO OTHERS AS WELL AS VEHICLE DAMAGE.**

EYE PROTECTION:

ALWAYS WEAR SAFETY GLASSES OR GOGGLES DURING THE INSTALLATION PROCESS TO AVOID PERSONAL INJURY.

MAXIMUM TOWING/CARRYING CAPACITY:

The Westin Receiver Hitches will have a visible tow rating label affixed directly on the product. User should never exceed the vehicle manufacturers maximum tow and weight rating regardless of the capacity of the hitch. **FAILURE TO FOLLOW THESE GUIDELINES WILL VOID THE WESTIN WARRANTY AND MAY RESULT IN PERSONAL INJURY AND/OR INJURY TO OTHERS AS WELL AS VEHICLE DAMAGE.**