

# INSTALLATION INSTRUCTIONS

## WJ2 FRONT BUMPER SKID PLATE



**APPLICATION:**  
2018 Jeep Wrangler JL  
**PART NUMBER:**  
59-80095

CONTENT			
ITEM	QUANTITY	DESCRIPTION	TOOLS NEEDED
1	1	SKID PLATE	16MM SOCKET
2	2	MOUNTING BRACKETS	16MM WRENCH
3	4	M8 HEX HEAD FLANGE BOLT	RATCHET
4	8	M8 SERRATED FLANGE NUT	TORQUE WRENCH
5	4	SHORT M8 HEX HEAD CAP SCREW	ALLEN WRENCH
6	6	M8 HEX SOCKET BUTTON HEAD SCREW	
7	6	LARGE M8 FLAT WASHER	
8	5	SMALL M8 FLAT WASHER	
9	6	M8 SPLIT LOCK WASHER	
10	1	LONG M8 HEX HEAD CAP SCREW	
11	2	M8 SPLINED RIVCERT	
12	4	M8 HEX RIVCERT	
13	1	UNIVERSAL RIVCERT TOOL	
14	1	CLOSE OUT PANEL	

**ANTI-SEIZE LUBRICANT MUST BE USED ON ALL STAINLESS STEEL FASTENERS TO PREVENT THREAD DAMAGE AND GALLING**

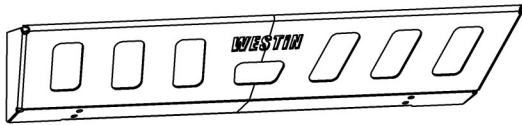

ITEM 1

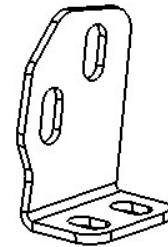

ITEM 2

Driver's Side Shown, Passenger Side Opposite



## PROCEDURE

1. Remove contents from box, verify if all parts listed are present and free from damage.  
Carefully read and understand all instructions before attempting installation.  
**Failure to identify damage before installation could lead to a rejection of any claim.**
2. Obtain the Skid Plate Mounting Brackets (2) along with the supplied M8 Hardware (3-12).
3. Secure the Skid Plate Mounting Brackets (2) to the Skid Plate Assembly (1) as shown in **Figure 1**.

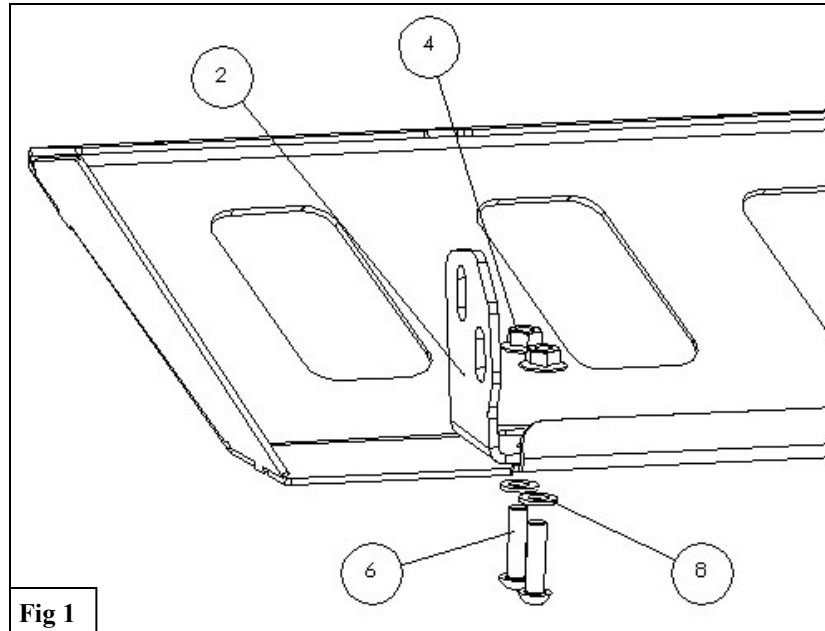

Fig 1

4. Loosely install skid (1) plate with the supplied M8 flange bolts (3) and M8 serrated flange nuts (4) according to **Figures 2 & 3**. **Note:** For Rubicon models with auto sway bar disconnect, a wobble socket is recommended to tighten the inner two bolts

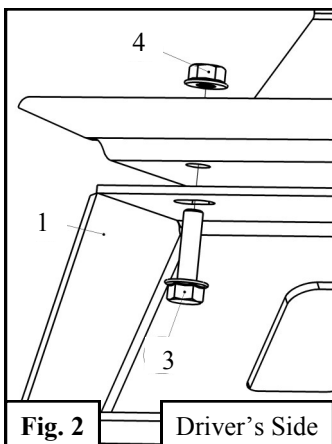

Fig. 2 Driver's Side

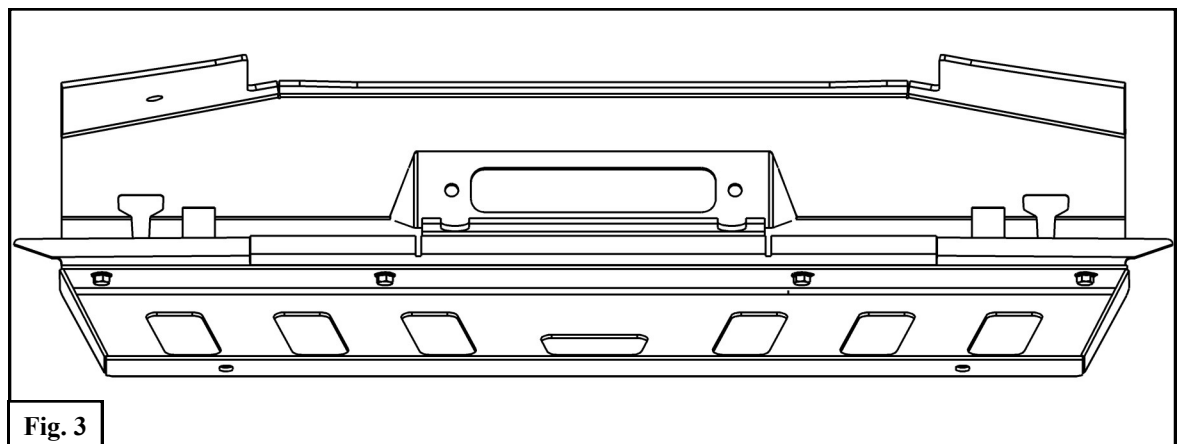
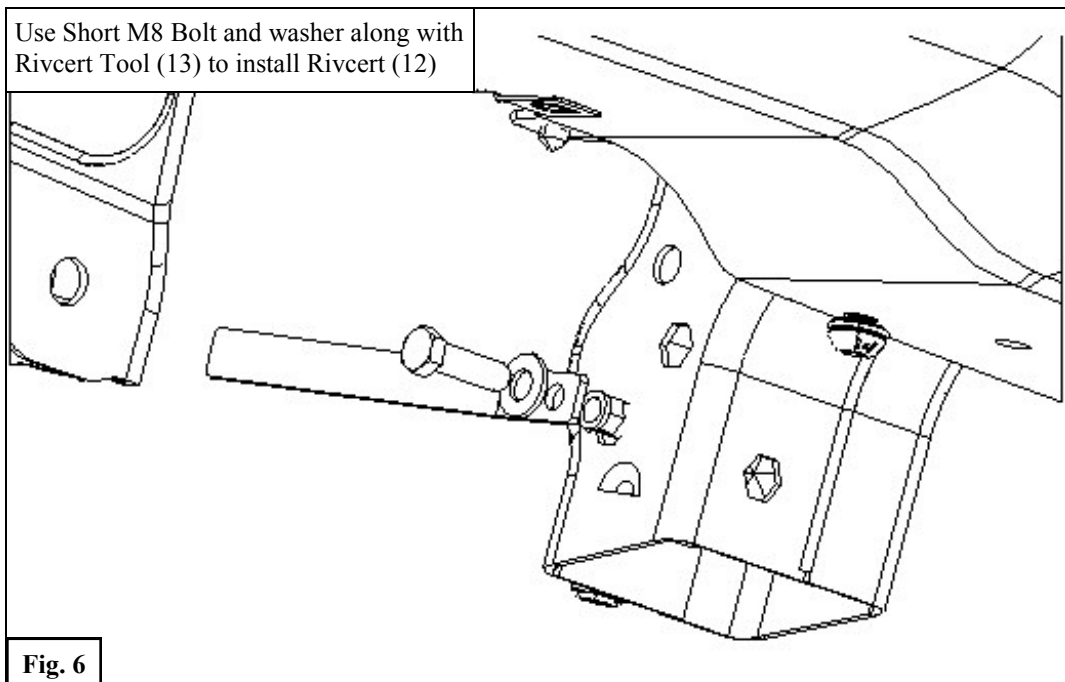
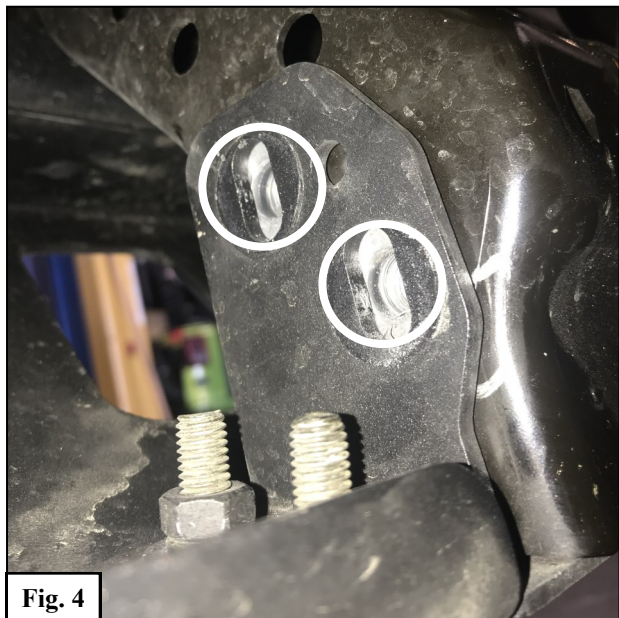

Fig. 3

5. For models with OEM steel bumpers, there will be M10 Hardware with rivcets already in place. See **Figure 4**.
6. In this case, use the OEM bolts to secure the Skid Plate Mounting Bracket to the vehicle. See **Figure 5**.
7. For models with OEM plastic bumpers, the supplied M8 Hex Rivcets (12) will be used along with the supplied short M8 Hex Bolts (5), Flat Washer (7), and Lock Washer (9). See **Figure 6** for Rivcert Installation.



## CLOSE OUT PANEL & RIVCERT INSTALLATION INSTRUCTIONS

- Before installing the close out panel (14), widen the hole in the frame indicated in **Figure 7** to 7/16" with a drill. Repeat procedure on the passenger's side. **Note:** Driver's side is shown.
- Slip an M8 flat washer (8) over the long M8 hex head cap screw (10) and then insert the cap screw into the M8 universal rivcert tool (13). Loosely thread the long M8 hex head cap screw into an M8 splined rivcert (11). See **Figure 8**.
- Insert the M8 rivcert (11) into the driver's side hole widened in step 6 and tighten the M8 hex head cap screw while simultaneously applying pressure with the rivcert tool until there is significant resistance. **Note:** When the rivcert is installed, it will have collapsed and fastened itself to the hole. See **Figure 9**.
- Remove the hex head cap screw, washer, and rivcert tool. Repeat steps 6-8 on the passenger's side of the vehicle.

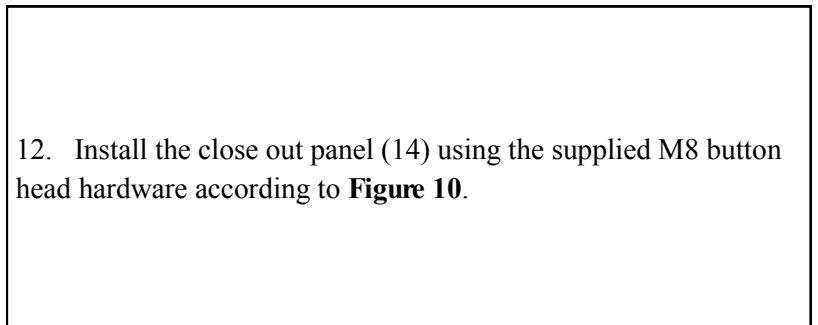
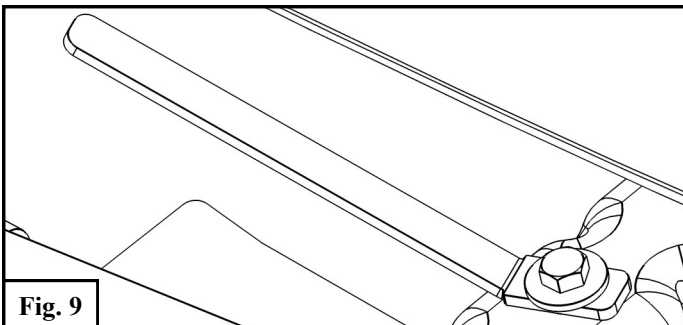
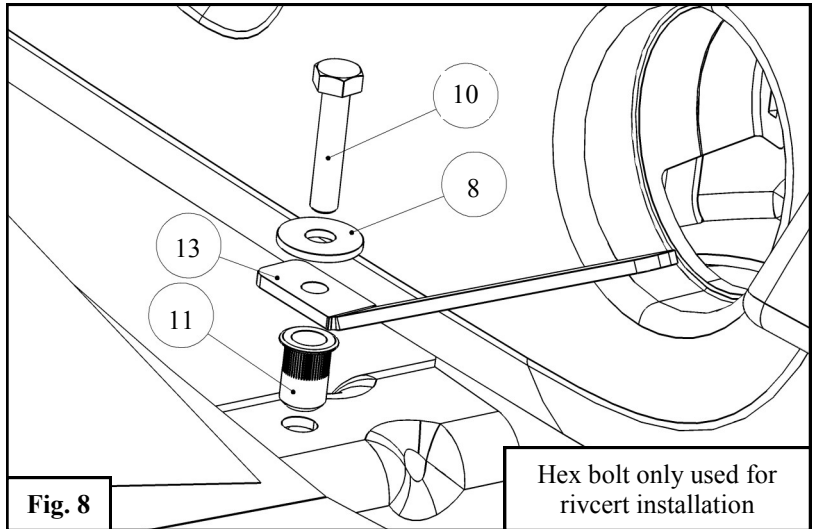
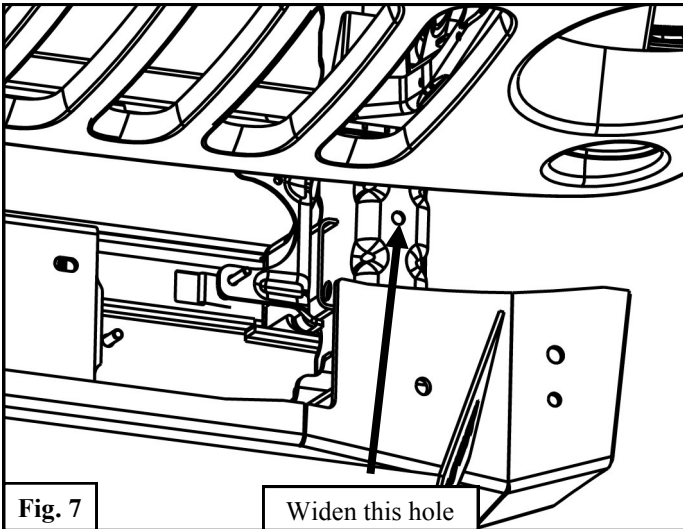

- Install the close out panel (14) using the supplied M8 button head hardware according to **Figure 10**.

**Installation Complete (Lights, Winch, and Bumper Sold Separately)**



**WJ2 BUMPERS**

#WESTINAUTOMOTIVE

#### CARE INSTRUCTIONS

- REGULAR WAXING IS RECOMMENDED. DO NOT USE ANY TYPE OF POLISH OR WAX THAT MAY CONTAIN ABRASIVES
- STAINLESS STEEL PRODUCTS CAN BE CLEANED WITH MILD SOAP AND WATER. STAINLESS STEEL POLISH SHOULD BE USED TO POLISH SMALL SCRATCHES.
- GLOSS BLACK FINISHES SHOULD BE CLEANED WITH MILD SOAP AND WATER

**WESTIN**



## **WARNING**



Failure to follow these instructions could lead to death, personal injury, and / or property damage.

Failure to follow these instructions could lead to death, personal injury, and / or property damage.

### **FASTENERS:**

All Westin supplied fasteners must be utilized and installed in accordance with the installation instructions and apply torque to the specifications as defined. **DOUBLE CHECK ALL FASTENERS BEFORE INITIAL USE, AND PERIODICALLY IN THE FUTURE TO ENSURE PROPER FUNCTION AND SAFETY.**

### **DRILLING:**

Most Westin products do not require drilling for installation. If drilling is defined as required, use caution when drilling a vehicle. **FAILURE TO REVIEW AN AREA TO BE DRILLED MAY RESULT IN PERSONAL INJURY AND/OR INJURY TO OTHERS AS WELL AS VEHICLE DAMAGE.**

### **EYE PROTECTION:**

**ALWAYS WEAR SAFETY GLASSES OR GOGGLES DURING THE INSTALLATION PROCESS TO AVOID PERSONAL INJURY.**

### **MAXIMUM TOWING/CARRYING CAPACITY:**

The Westin Receiver Hitches will have a visible tow rating label affixed directly on the product. User should never exceed the vehicle manufacturers maximum tow and weight rating regardless of the capacity of the hitch. **FAILURE TO FOLLOW THESE GUIDELINES WILL VOID THE WESTIN WARRANTY AND MAY RESULT IN PERSONAL INJURY AND/OR INJURY TO OTHERS AS WELL AS VEHICLE DAMAGE.**

