

INSTALLATION INSTRUCTIONS



WJ2 Skid Plate, WJ2 Skid Plate (Lighted)

APPLICATION:

2007-2018 Jeep Wrangler JK

PART NUMBER:

59-80005-SP, 59-88005

CONTENT			
ITEM	QUANTITY	DESCRIPTION	TOOLS NEEDED
1	1	SKID PLATE	DRILL MOTOR
2	1	CLOSE OUT PANEL	7/16" DRILL BIT
3	4	SPACER WASHER	13MM SOCKET
4	4*	M8 HEX HEAD FLANGE BOLT (BLACK ZINC) <i>*Only 2 included with lighted skid plate</i>	13MM WRENCH
5	4*	M8 SERRATED FLANGE NUT (BLACK ZINC) <i>*Only 2 included with lighted skid plate</i>	15MM SOCKET
6	2	M10 U-CLIP (BLACK ZINC)	15MM WRENCH
7	2	M10 BUTTONHEAD SCREW (BLACK ZINC)	WOBBLE SOCKET
8	2	M10 FLAT WASHER (BLACK ZINC)	ALLEN WRENCH
9	2	M10 SPLIT LOCK WASHER (BLACK ZINC)	RATCHET
10	2	M8 BUTTON HEAD SCREW (BLACK ZINC)	
11	2*	M8 FLAT WASHER (BLACK ZINC) <i>*2 additional included with lighted skid plate</i>	
12	2*	M8 SPLIT LOCK WASHER (BLACK ZINC) <i>*2 additional included with lighted skid plate</i>	
13	1	M8 HEX HEAD CAP SCREW (YELLOW ZINC)	
14	2	M8 SPLINED RIVCERT (YELLOW ZINC)	
15	1	M8 UNIVERSAL RIVCERT TOOL	
16	2	M6 CARRIAGE BOLT (only included for 59-88005)	
17	2	M6 HEX NUT (only included for 59-88005)	
18	2	M6 FLAT WASHER (only included for 59-88005)	
19	2	M6 SPLIT LOCK WASHER (only included for 59-88005)	
20	2	SHORT M8 HEX HEAD CAP SCREW (only included for 59-88005)	
21	2	M6 POLY RETAINER (only included for 59-88005)	
22	1	LED LIGHT BAR (only included for 59-88005)	
23	1	LED WIRING HARNESS (only included for 59-88005)	

ANTI-SEIZE LUBRICANT MUST BE USED ON ALL STAINLESS STEEL FASTENERS TO PREVENT THREAD DAMAGE AND GALLING

NOTE: WJ2 STUBBY BUMPER MUST BE INSTALLED BEFORE SKID PLATE CAN BE INSTALLED



PROCEDURE

1. Remove contents from box, verify if all parts listed are present and free from damage.
Carefully read and understand all instructions before attempting installation.
Failure to identify damage before installation could lead to a rejection of any claim.

ITEM 1 (Unlighted)

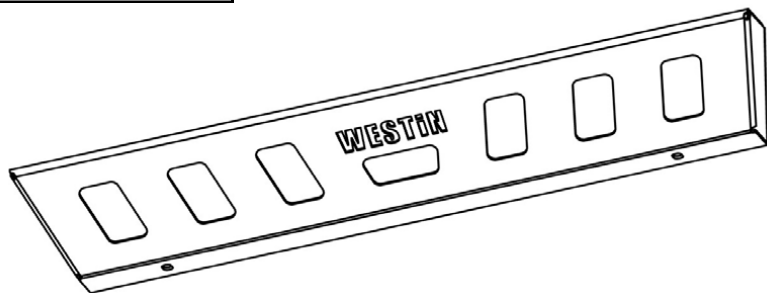

ITEM 1 (Lighted)

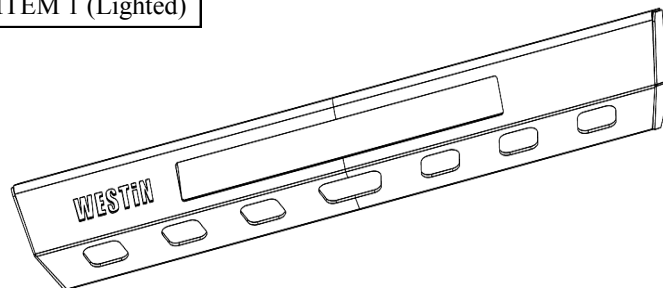

ITEM 2

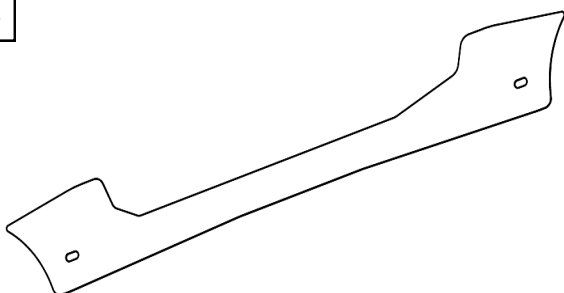

ITEM 3

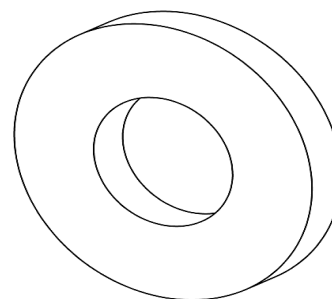

ITEM 22

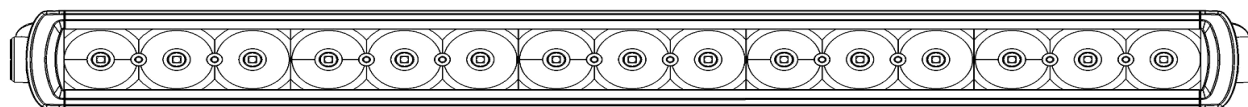

2. Insert M10 U-clips (6) inside the frame by sliding them in through the square holes. See **Figure 1**.

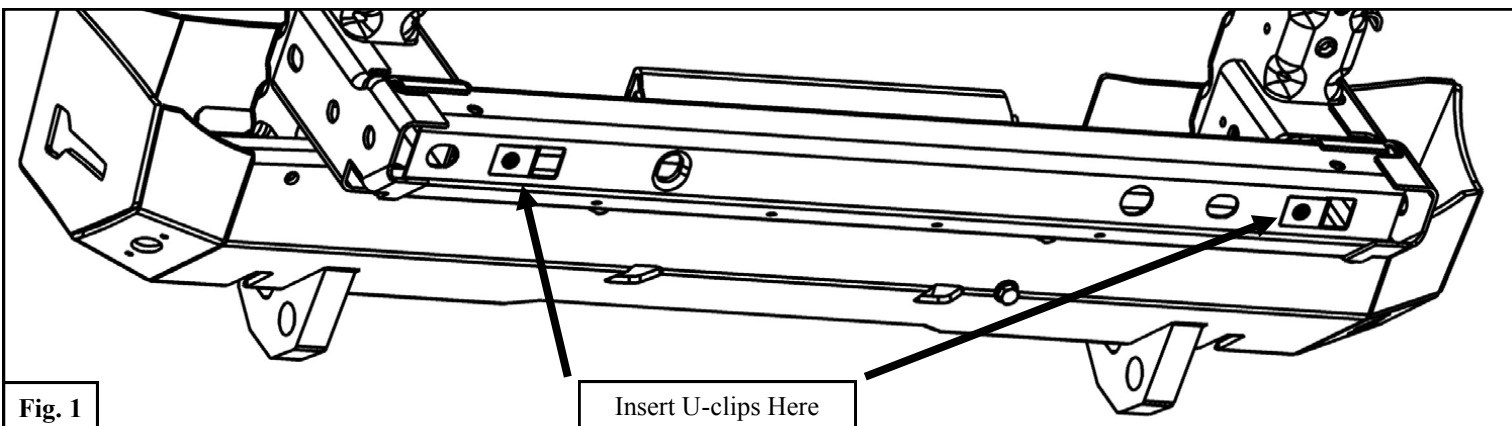
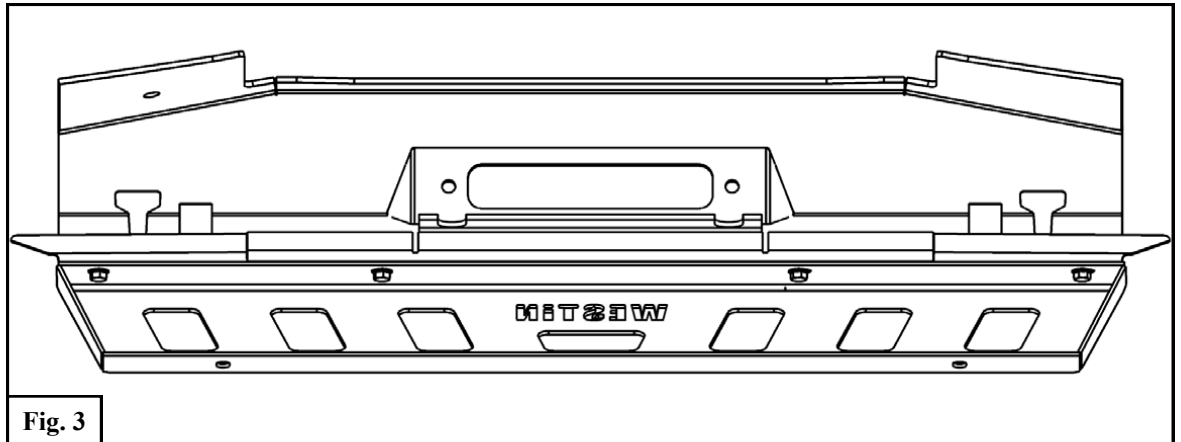
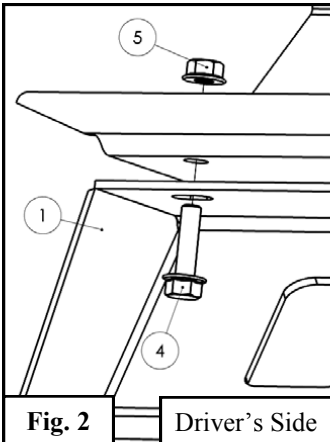

Fig. 1

Insert U-clips Here

Unlighted Skid Plate Installation

- Loosely install skid (1) plate with the supplied M8 flange bolts (4) and M8 serrated flange nuts (5) according to **Figures 2 & 3**. **Note:** For Rubicon models with auto sway bar disconnect, a wobble socket is recommended to tighten the inner two bolts



- Loosely install the supplied M10 hardware (7-9) and spacer washers (3) as needed on both sides of the vehicle. See **Figure 4**.

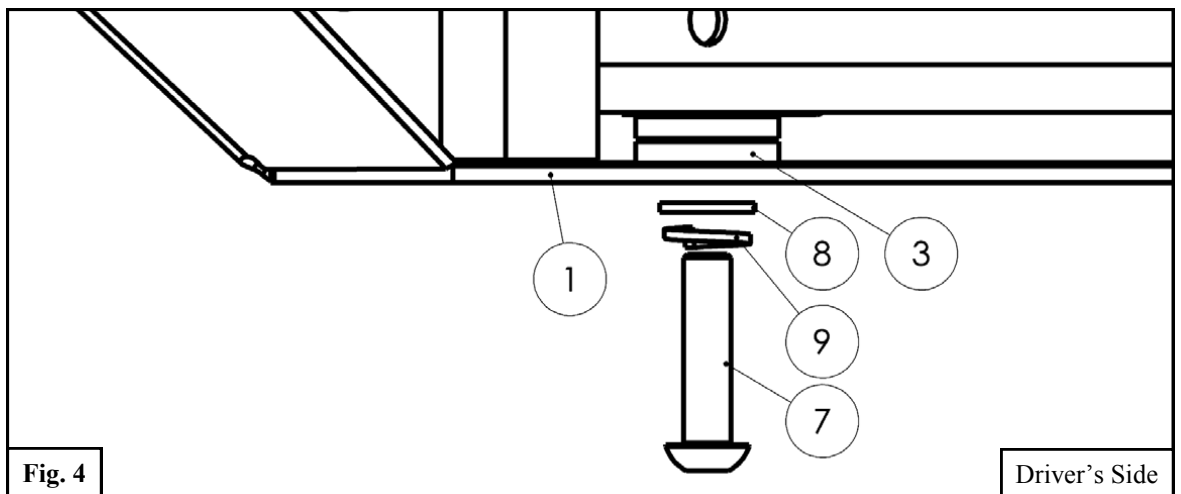

Lighted Skid Plate Installation

- Install light into skid plate per instructions on **Page 5**.
- Loosely install skid (1) plate with the supplied M8 flange bolts (4) and M8 serrated flange nuts (5) according to **Figures 2 & 3**.

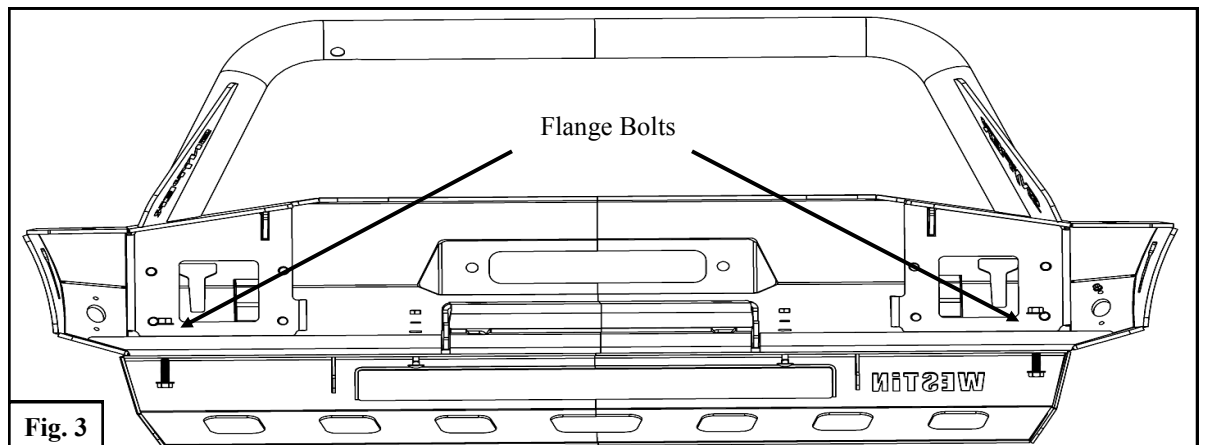
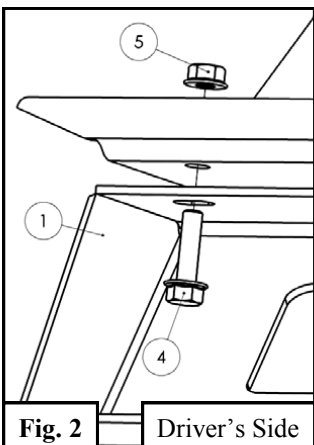

5. Loosely install the supplied M6 Carriage Bolts (16), lock washers (19), flat washers (18), and hex nuts (17) according to **Figures 4 & 5**. *Note:* At this time, the poly retainers (21) will be used to hold the carriage bolt in place while installing the other M6 hardware.

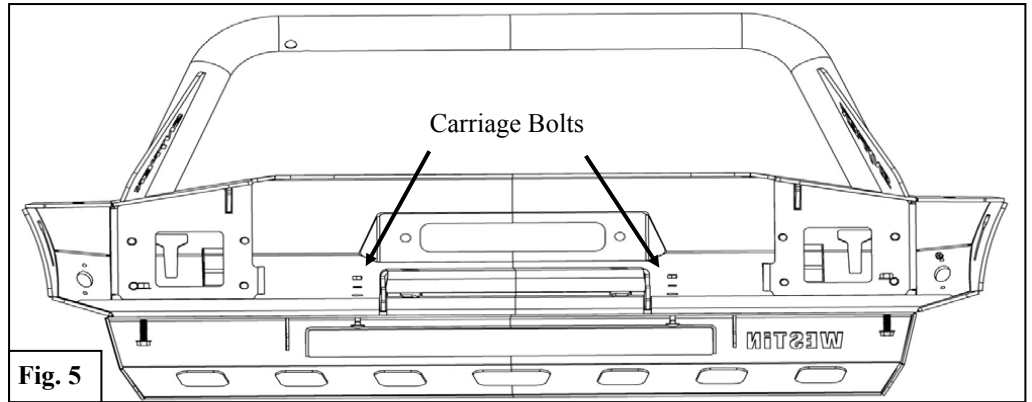
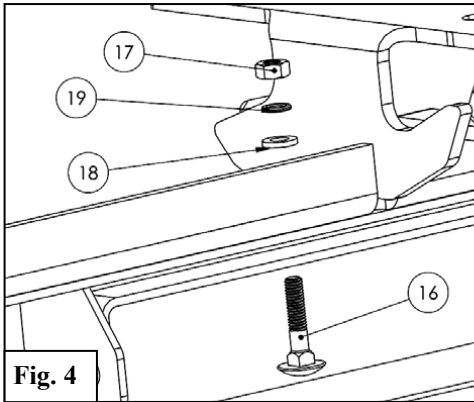

6. Loosely install the supplied M10 hardware (7-9) and spacer washers as needed on both sides of the vehicle. See **Figure 6**.

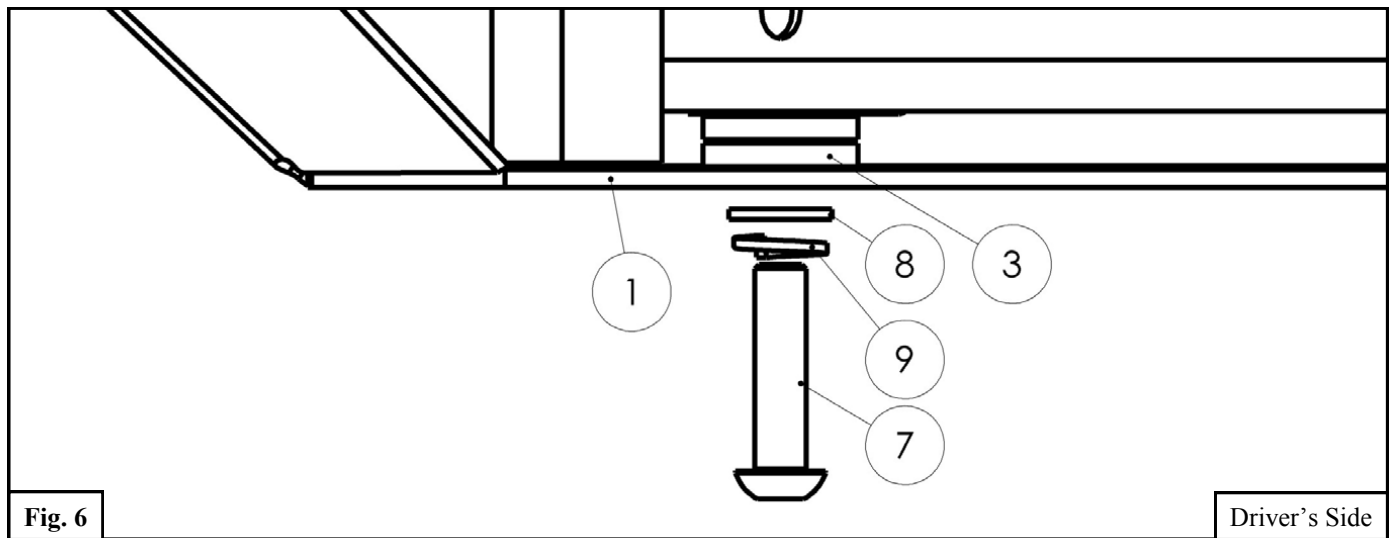

LED Light Bar Installation

CAUTION:

1. Check with state and local authorities for laws governing usage and proper mounting of auxiliary lamps.
2. Keep heat sink clean and exposed to maintain air-flow.

PROCEDURE

1. Remove contents from box, verify if all parts listed are present and free from damage.
Carefully read and understand all instructions before attempting installation.
2. Attach to the light bar all hardware included with the light bar, and Install LED light as shown on **Figure 7**.
3. **Align the light to a desired position and torque M8 hardware to 15 ft-lbs.**

Fig. 7

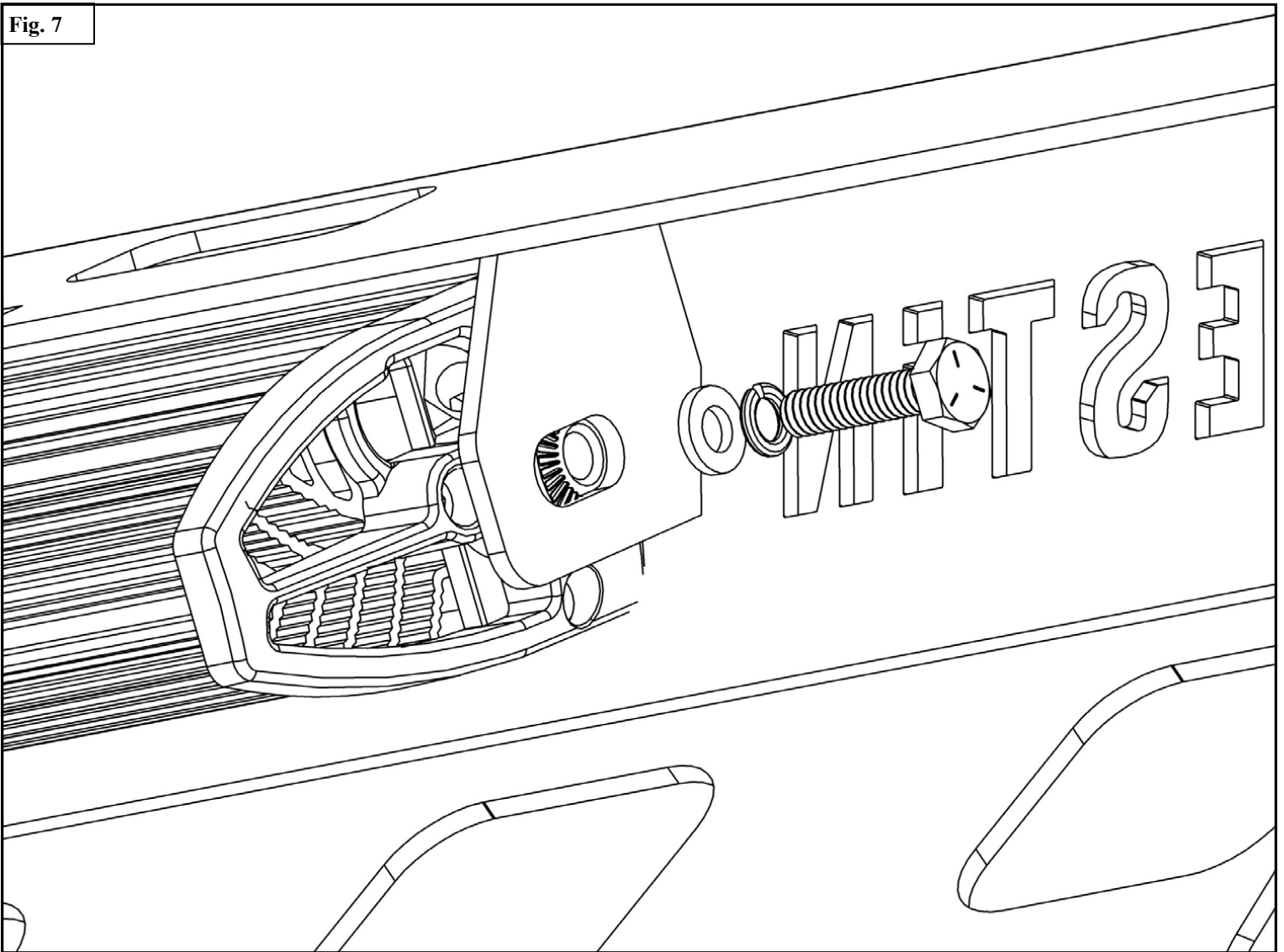

CLOSE OUT PANNEL & RIVCERT INSTALLATION INSTRUCTIONS

1. Before installing the close out panel (2), widen the hole in the frame indicated in **Figure 8** to 7/16" with a drill. Repeat procedure on the passenger's side. **Note:** Driver's side is shown.
2. Slip an M8 flat washer (11) over the M8 hex head cap screw (13) and then insert the cap screw into the M8 universal rivcert tool (15). Loosely thread the M8 hex head cap screw into an M8 splined rivcert (14). See **Figure 9**.
3. Insert the M8 rivcert (14) into the driver's side hole widened in step 5 and tighten the M8 hex head cap screw while simultaneously applying pressure with the rivcert tool until there is significant resistance. **Note:** When the rivcert is installed, it will have collapsed and fastened itself to the hole. See **Figure 10**.
4. Remove the hex head cap screw, washer, and rivcert tool. Repeat steps 6 & 7 on the passenger's side of the vehicle.

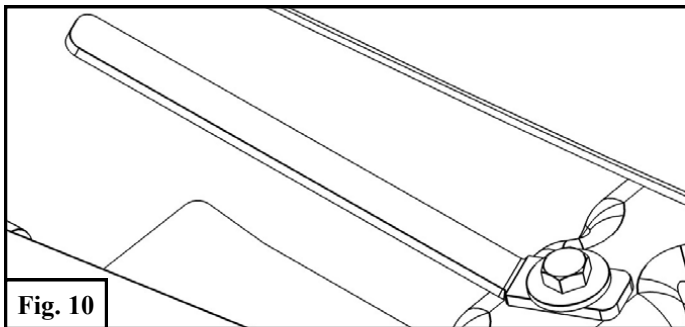
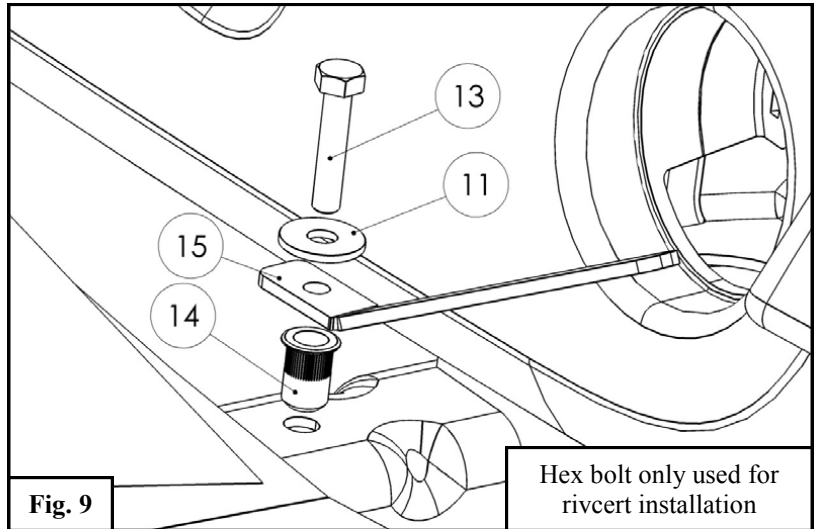
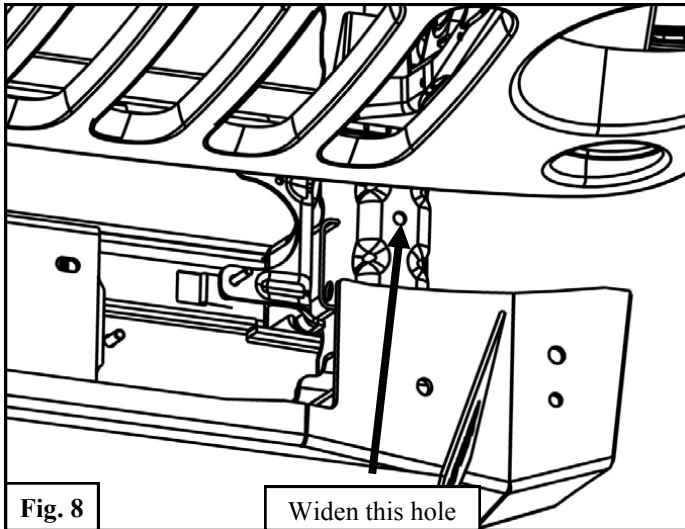

10. Install the close out panel (2) using the supplied M8 button head hardware according to **Figures 11 & 12**. **Note:** Figure 11 omits the front bumper to give a better view of the close out panel's position.

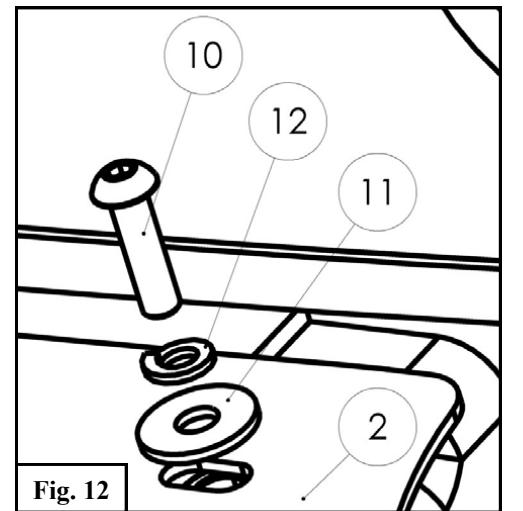
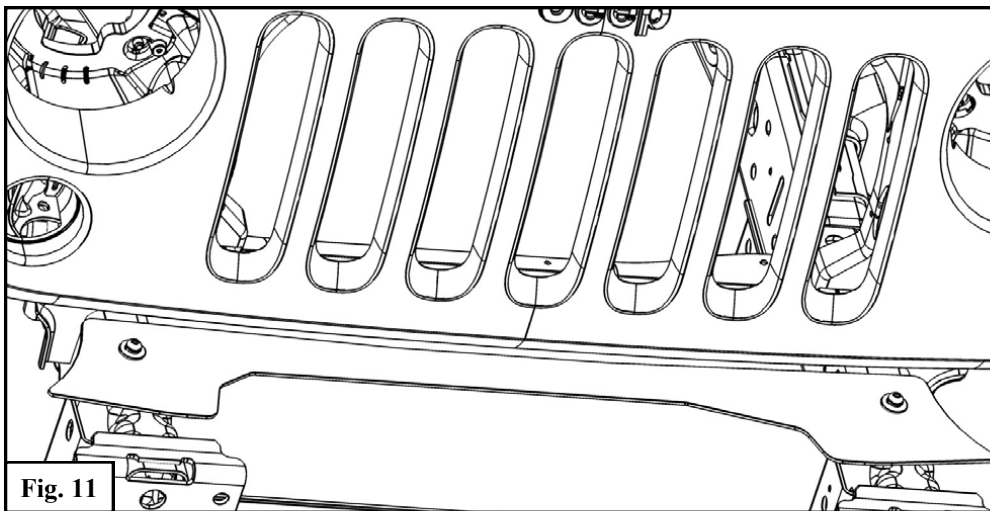

WIRING INSTRUCTIONS:

WESTIN recommends using a professional for this installation.

CAUTION:

1. Disconnect ground connection from battery (-) to avoid accidental short circuits before attempting to connect electrical wires.
2. When running wires, avoid areas of excessive heat, vibration, pinch or rotation when securing harness to vehicle.
3. Always use a fused (+) positive supply source.
4. This light becomes hot under continuous use. Do not remove or touch the casting for at least 30 minutes after the lamp has been turned off.

Refer to Figure 3.

1. Locate wiring harness and mount the switch in a convenient location where it is easily accessible from the drivers seat.
Note: *The switch will need to be removed from the wiring harness so that the rest of the harness can be routed from the engine bay to the cabin.*
2. Route the wiring harness wire, specifically the fuse and relay, from the positive battery terminal along the firewalls existing wire routes. **Note:** *Tape as necessary to correct slack.*
3. Secure the relay by either drilling or using a pre-existing bolt along the chassis that is not connected to any other wire.
4. Run the switch harness through the firewall preferably through the pre-existing rubber plug that is used to run the OEM wiring harness from the engine bay to fuse box. **Note:** *Reconnect the switch to the wiring harness.*
5. Place the LED plug wire along the fender chassis where it will not get pinched and away from any moving parts (fan, pulleys etc.).
6. Run the attached wire from the LED Light Bar as previously mentioned away from any moving parts.
7. Connect both ends of wiring connectors from LED light bar and wiring harness.
8. Re-connect battery terminals, attach the Red (+) wire to battery positive, and the black (-) wire to ground. **Note:** *Add dielectric grease (not supplied).*
9. Turn on the switch to make sure if the lamp works. If not, please check carefully if the wiring installation is correct.

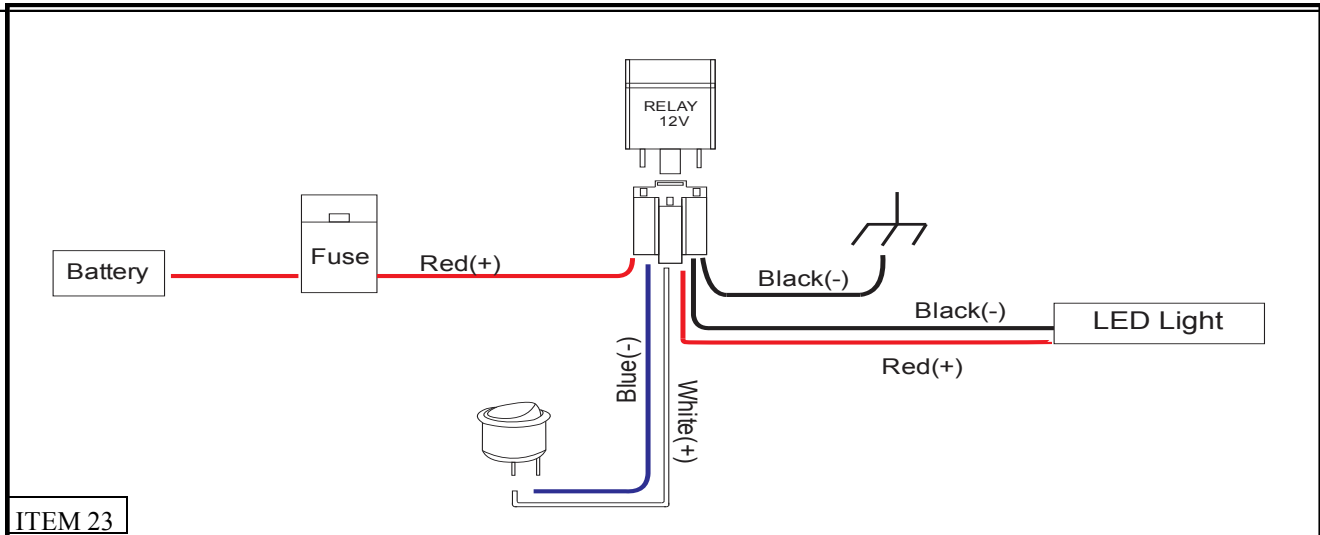

CARE INSTRUCTIONS

- REGULAR WAXING IS RECOMMENDED. DO NOT USE ANY TYPE OF POLISH OR WAX THAT MAY CONTAIN ABRASIVES.
- STAINLESS STEEL PRODUCTS CAN BE CLEANED WITH MILD SOAP AND WATER. STAINLESS STEEL POLISH SHOULD BE USED TO POLISH SMALL SCRATCHES.
- GLOSS BLACK FINISHES SHOULD BE CLEANED WITH MILD SOAP AND WATER.

11. Tighten all hardware to the following specifications. M8 hardware to 15-18 ft-lbs, M10 hardware to 30-35 ft-lbs, and M6 hardware to 5-7 ft-lbs.

INSTALLATION COMPLETE



Lighted Shown



Unlighted Shown

CARE INSTRUCTIONS

- REGULAR WAXING IS RECOMMENDED. DO NOT USE ANY TYPE OF POLISH OR WAX THAT MAY CONTAIN ABRASIVES.
- STAINLESS STEEL PRODUCTS CAN BE CLEANED WITH MILD SOAP AND WATER. STAINLESS STEEL POLISH SHOULD BE USED TO POLISH SMALL SCRATCHES.
- GLOSS BLACK FINISHES SHOULD BE CLEANED WITH MILD SOAP AND WATER.

WESTIN