

# INSTALLATION INSTRUCTIONS

## OUTLAW REAR BUMPER



**APPLICATION:**  
2017-2019 Ford Raptor  
**PART NUMBER:**  
58-82025

<b>CONTENT</b>			
<b>ITEM</b>	<b>QUANTITY</b>	<b>DESCRIPTION</b>	<b>TOOLS NEEDED</b>
1	1	REAR BUMPER	13MM SOCKET
2,3	2	MAIN BRACKET, DRIVER (2) AND PASSENGER (3)	RATCHET
4	4	SENSOR L-TAB	TORQUE WRENCH
5	2	LED CUTOUT MESH COVER	19MM SOCKET
6	1	LICENSE PLATE SWING MOUNT	17MM SOCKET
7	1	TRAILER CONNECTOR BRACKET	5MM ALLEN
8	2	EXHASUT SUPPORT	PRY TOOL
9	10	M12 HEX HEAD BOLT (BLACK ZINC)	M10 WRENCH
10	10	M12 HEX NUT (BLACK ZINC)	
11	20	M12 FLAT WASHER (BLACK ZINC)	
12	10	M12 SPLIT LOCK WASHER (BLACK ZINC)	
13	2	M8 CARRIAGE BOLT (BLACK ZINC)	
14	2	M8 HEX NUT (BLACK ZINC)	
15	2	M8 SPLIT LOCK WASHER (BLACK ZINC)	
16	2	M8 FLAT WASHER (BLACK ZINC)	
17	4	M6 CARRIAGE BOLT (BLACK ZINC)	
18	4	M6 HEX NUT (BLACK ZINC)	
19	4	M6 SPLIT LOCK WASHER (BLACK ZINC)	
20	4	M6 FLAT WASHER (BLACK ZINC)	
21	5	M6 SEMS HARDWARE (BLACK ZINC)	
22	10	ZIP TIE	
23	10	ZIP TIE ADHESIVE SQUARE MOUNT	
24	2	T-TAB CONNECTOR MALE	
25	2	T-TAB CONNECTOR FEMALE	

**ANTI-SEIZE LUBRICANT MUST BE USED ON ALL STAINLESS STEEL FASTENERS TO PREVENT THREAD DAMAGE AND GALLING**



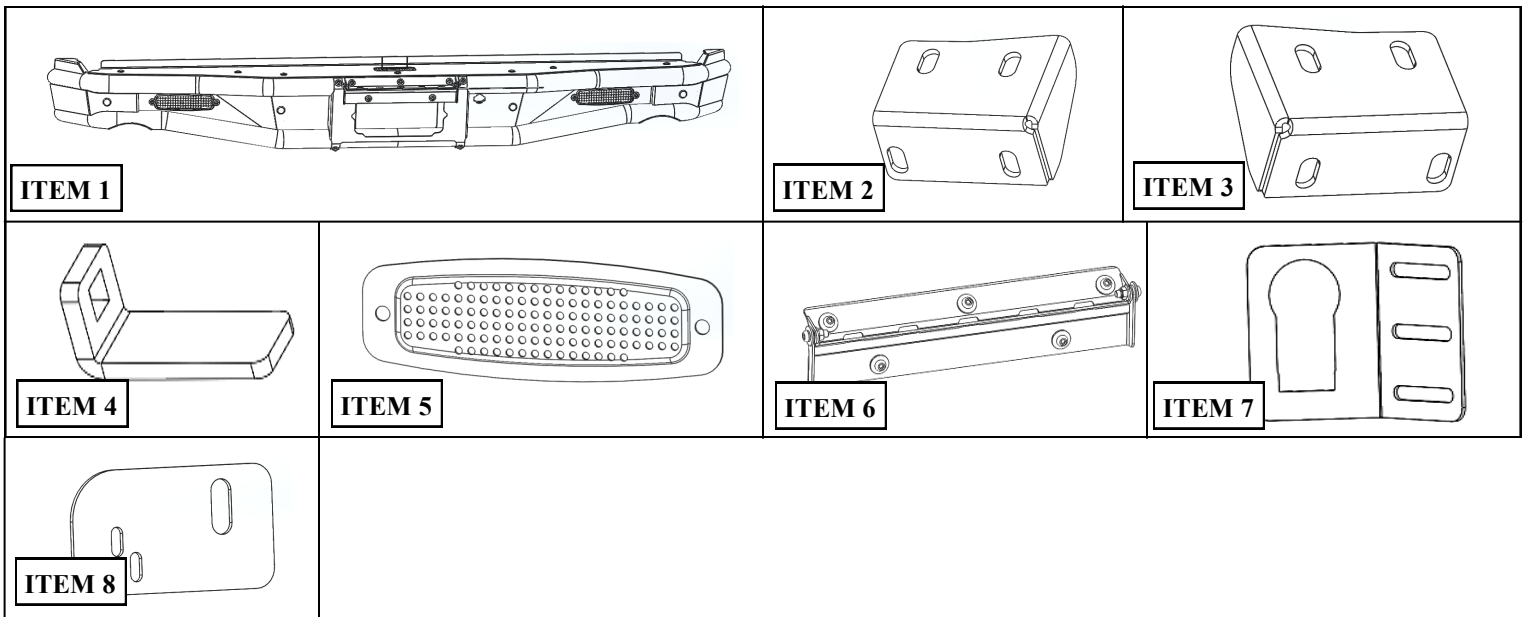

### PROCEDURE

1. Remove contents from box, verify if all parts listed are present and free from damage. Carefully read and understand all instructions before attempting installation.  
**Failure to identify damage before installation could lead to a rejection of any claim.**

**NOTE: This bumper is compatible with the OEM hitch by removing a non structural component of the hitch. See procedure for details.**

**Also, this bumper can be installed with the Westin Outlaw accessory hitch. Part number 58-81015H.**

2. Disconnect all electrical connections and parking sensors from the stock rear bumper.
3. On the driver's side of the vehicle, remove the three bolts indicated in **Figure 1**. Repeat procedure on the passenger's side. *Note:* Support the stock bumper while bolts are removed.
4. Remove stock bumper/hitch assembly.

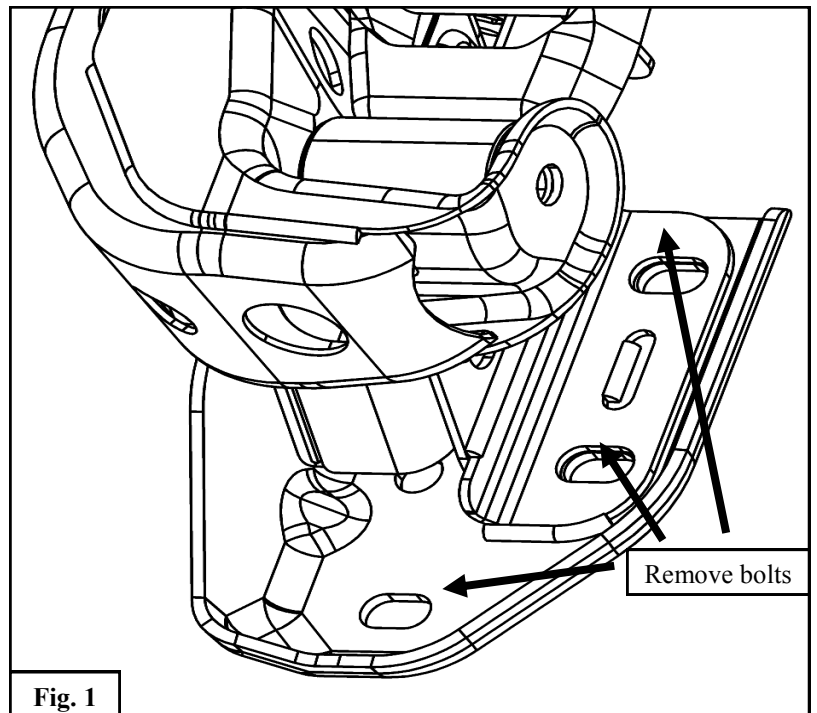

5. In order to use OEM hitch, grind off the 5 welds holding the license plate sheet metal part. After removal, the hitch should look as shown on **Fig. 2**. Spray paint the raw metal to avoid rust.
6. After modifying the hitch, mount back on the vehicle with main brackets **Items 2,3** using M12 hardware **Items 9-12**. See **Fig. 3**



7. Using M12 hardware **Items 9-12**, mount bumper to main brackets. ( Removing the bumper's top plate using a screw driver will make step #7 easier)

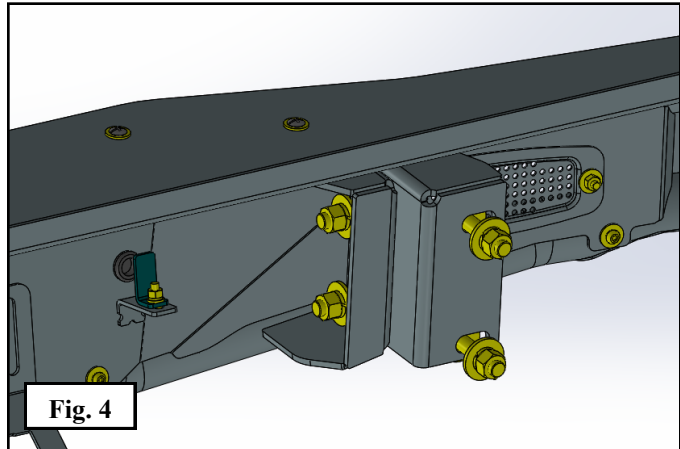
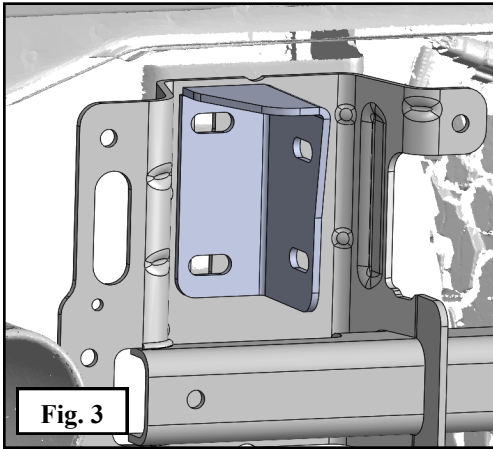

8. If you are using Westin hitch accessory 58-81015H, mount as shown on **Fig. 5**.
9. Install exhaust support Item 8 as shown on **Fig.6**.

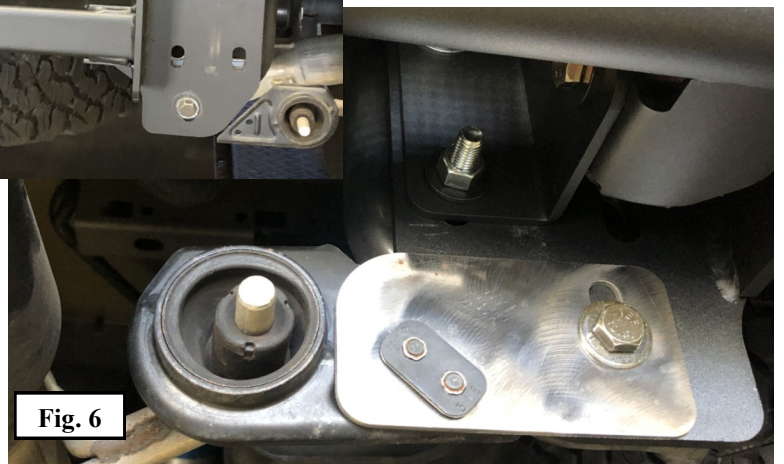

**WARNING:**

After you have mounted the bumper, CAREFULLY open tailgate. While tailgate is open, adjust the height of the bumper so that it has about 3/8" of clearance with respect to the tailgate.

10. Install parking sensors centered with bumper holes and press them with L-tabs (4) against bumper plate. Firmly fasten L-tabs with the supplied M6 hardware (18-21). See **Figure 7**.

11. Use zip ties and zip tie mounts (22 & 23) to secure sensor wires in place.

*Note:* Be sure to maintain the orientation of the sensor so that it remains consistent with its original orientation.

12. Tighten M6 hardware to 5-7 ft-lbs.

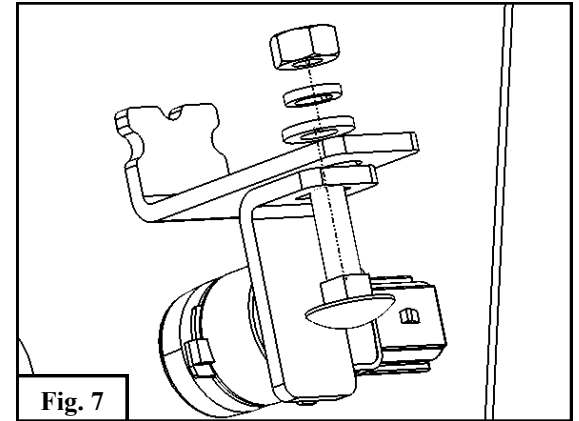

11. Using M8 hardware (13-16), install trailer connector bracket (7) to the back plate of the bumper. Adjust up and down as desired and tighten M8 hardware to 15-18 ft-lbs. See **Figure 8**.

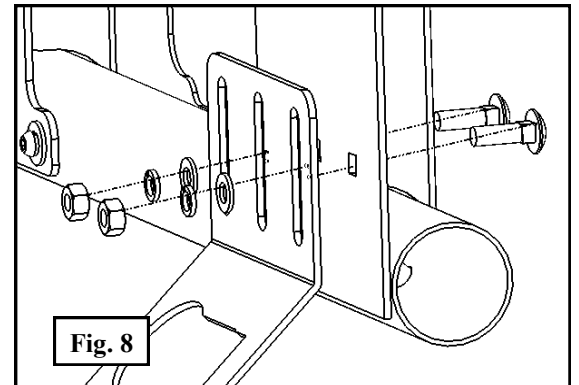

12. Using M6 SEMS button head hardware (21), install license plate swing mount (6) on bumper. Tighten M6 hardware to 5-7 ft-lbs.

See **Figure 9**.

13. Tighten the two nylon lock nuts on the sides until it has just enough resistance to prevent rotation due to normal condition while still allowing rotation by hand when desired or needed to access hitch.

14. Tighten all M12 hardware to 65ft-lbs, M8 hardware to 14 ft-lbs and M6 to 7ft-lbs.

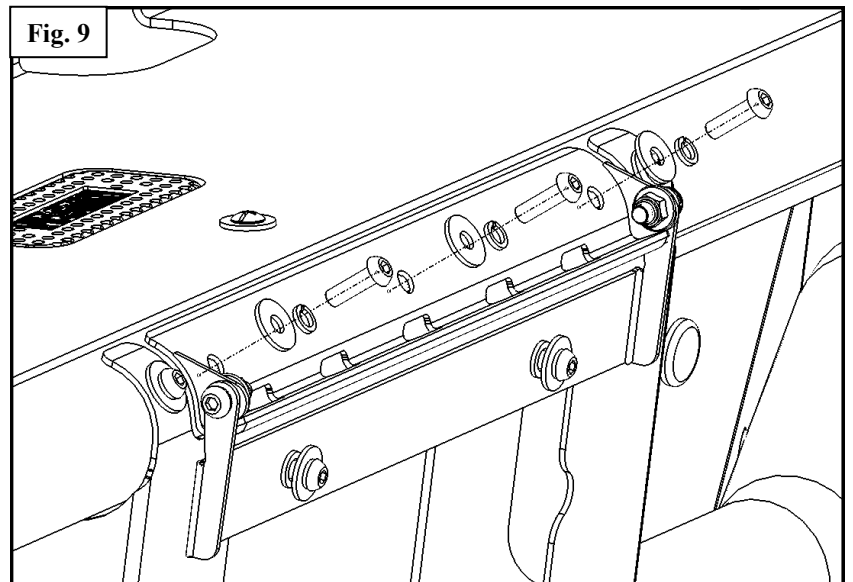

15. Using items 24 and 25 connect the LED license plate light to one of the OEM license plate lights. Connect the black cable from the LED tape to the black cable going into the OEM license plate light.

Then, connect the red cable on the LED tape to the colored (non-black) cable going to the OEM license plate light.

Crimp carefully and cover with electrical tape. Use supplied zip ties and zip tie mounts to position cables as desired.

## INSTALLATION COMPLETE



### CARE INSTRUCTIONS

- REGULAR WAXING IS RECOMMENDED. DO NOT USE ANY TYPE OF POLISH OR WAX THAT MAY CONTAIN ABRASIVES.
- STAINLESS STEEL PRODUCTS CAN BE CLEANED WITH MILD SOAP AND WATER. STAINLESS STEEL POLISH SHOULD BE USED TO POLISH SMALL SCRATCHES.
- GLOSS BLACK FINISHES SHOULD BE CLEANED WITH MILD SOAP AND WATER.

**WESTIN**



## WARNING



Failure to follow these instructions could lead to death, personal injury, and / or property damage.

### FASTENERS:

All Westin supplied fasteners must be utilized and installed in accordance with the installation instructions and apply torque to the specifications as defined. **DOUBLE CHECK ALL FASTENERS BEFORE INITIAL USE, AND PERIODICALLY IN THE FUTURE TO ENSURE PROPER FUNCTION AND SAFETY.**

### DRILLING:

Most Westin products do not require drilling for installation. If drilling is defined as required, use caution when drilling a vehicle. **FAILURE TO REVIEW AN AREA TO BE DRILLED MAY RESULT IN PERSONAL INJURY AND/OR INJURY TO OTHERS AS WELL AS VEHICLE DAMAGE.**

### EYE PROTECTION:

**ALWAYS WEAR SAFETY GLASSES OR GOGGLES DURING THE INSTALLATION PROCESS TO AVOID PERSONAL INJURY.**

### MAXIMUM TOWING/CARRYING CAPACITY:

The Westin Receiver Hitches will have a visible tow rating label affixed directly on the product. User should never exceed the vehicle manufacturers maximum tow and weight rating regardless of the capacity of the hitch. **FAILURE TO FOLLOW THESE GUIDELINES WILL VOID THE WESTIN WARRANTY AND MAY RESULT IN PERSONAL INJURY AND/OR INJURY TO OTHERS AS WELL AS VEHICLE DAMAGE.**

