

# INSTALLATION INSTRUCTIONS

## OUTLAW REAR BUMPER



**APPLICATION:**

Chevrolet, GMC

Silverado/Sierra 1500 2019-2020 (Excl. 2019 Silverado LD/Sierra 1500 Limited)

**PART NUMBER:**

58-81215

CONTENT			
ITEM	QUANTITY	DESCRIPTION	TOOLS NEEDED
1	1	REAR BUMPER	18MM WRENCH
2	1	MAIN DRIVER BRACKET	5MM ALLEN
3	1	MAIN PASSENGER BRACKET	13MM SOCKET
4	1	DRIVER EXHAUST TIP BRACKET	17MM SOCKET
5	1	PASSENGER EXHAUST TIP BRACKET	19MM SOCKET
6	4	SENSOR L-TAB	13MM WRENCH
7	1	TOW PLUG BRACKET	17MM WRENCH
8	2	LARGE L-TAB	19MM WRENCH
9	2	SPACERS	10MM SOCKET
10	10	M12 HEX HEAD BOLT (YELLOW ZINC)	10MM WRENCH
11	10	M12 HEX NUT (YELLOW ZINC)	PLYER TOOL
12	20	M12 FLAT WASHER (YELLOW ZINC)	RATCHET
13	10	M12 SPLIT LOCK WASHER (YELLOW ZINC)	TORQUE WRENCH
14	6	M8 HEX HEAD BOLT (YELLOW ZINC)	ELECTRICAL TAPE
15	6	M8 HEX NUT (YELLOW ZINC)	
16	6	M8 SPLIT LOCK WASHER (YELLOW ZINC)	
17	12	M8 FLAT WASHER (YELLOW ZINC)	
18	6	M6 CARRAIGE SCREW (BLACK ZINC)	
19	6	M6 HEX NUT (BLACK ZINC)	
20	6	M6 SPLIT LOCK WASHER (BLACK ZINC)	
21	6	M6 FLAT WASHER (BLACK ZINC)	
22	5	M6 BUTTON HEAD BOLTS (BLACK ZINC) (SEMS HARDWARE)	
23	5	M6 SPLIT LOCK WASHER (BLACK ZINC) (SEMS HARDWARE)	
24	5	M6 FLAT WASHER (BLACK ZINC) (SEMS HARDWARE)	
25	10	ZIP TIES	
26	10	ZIP TIE MOUNTS	
27	2	T-TAB CONNECTOR MALE	
28	2	T-TAB CONNECTOR FEMALE	

**ANTI-SEIZE LUBRICANT MUST BE USED ON ALL STAINLESS STEEL FASTENERS TO PREVENT THREAD DAMAGE AND GALLING**



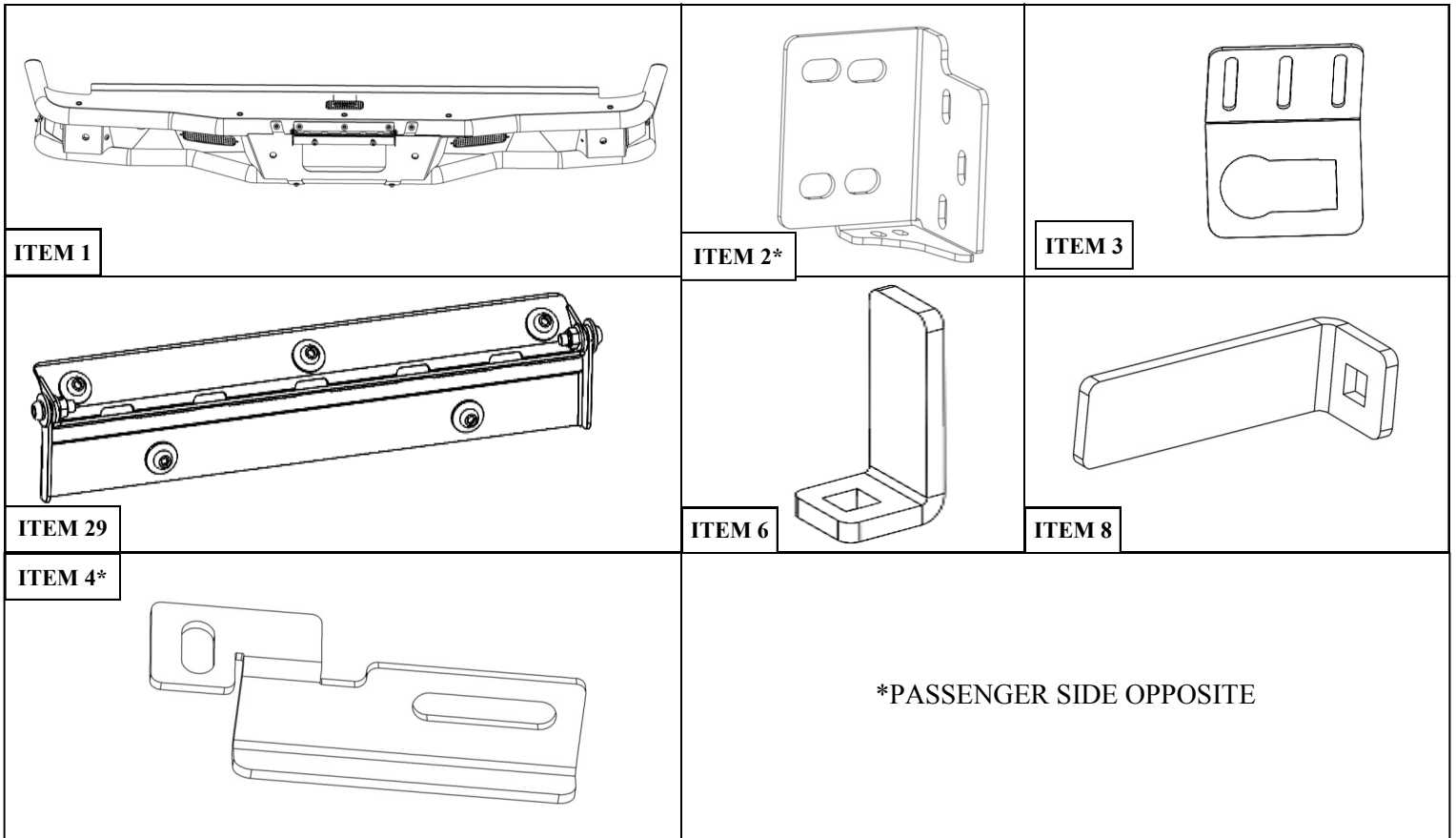

### PROCEDURE

1. Remove contents from box, verify if all parts listed are present and free from damage.  
Carefully read and understand all instructions before attempting installation.  
**Failure to identify damage before installation could lead to a rejection of any claim.**

### NOTE:

**THIS BUMPER IS NOT COMPATIBLE WITH OEM HITCH. HITCH 58-81215H IS AVAILABLE TO REPLACE OEM HITCH AND WORK WITH THIS BUMPER.**

2. Unbolt the factory hitch if equipped.
3. Remove all electrical connections from the rear bumper.
4. Remove the two nuts and two bolts on each side of the rear bumper. **See Figure 1-2**
5. Remove the rear bumper.

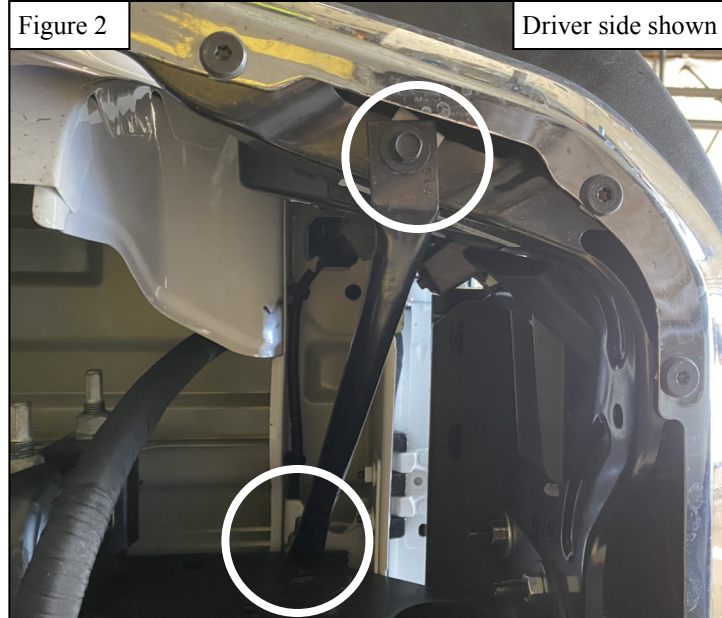
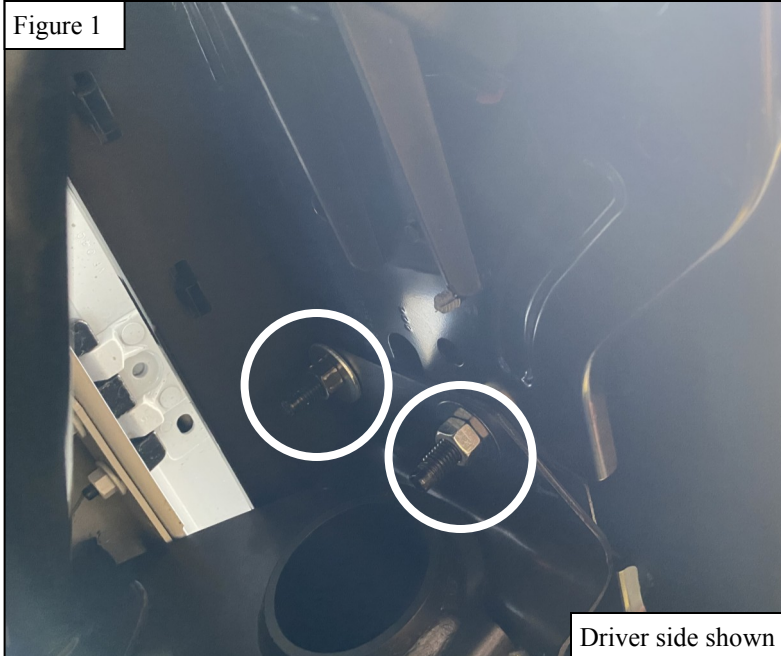

6. Install parking sensors by inserting into the holes on bumper and pressing with sensor L-tabs against bumper plate. Fasten L-tabs with the supplied M6 hardware (18-21). **See Figure 3.** Use supplied double sided tape between sensor and L-Tab to keep the sensor from rotating.
7. Use items 25 and 26 to secure sensor in place.  
*Note:* Be sure to maintain the orientation of the sensor so that it remains consistent with its original orientation.
8. Tighten M6 hardware to 5-7 ft-lbs.

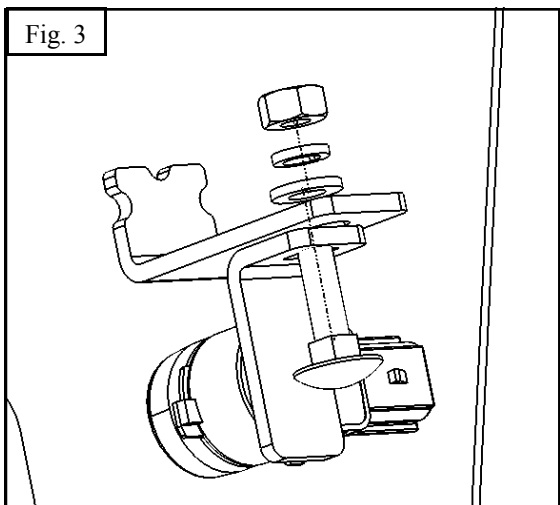
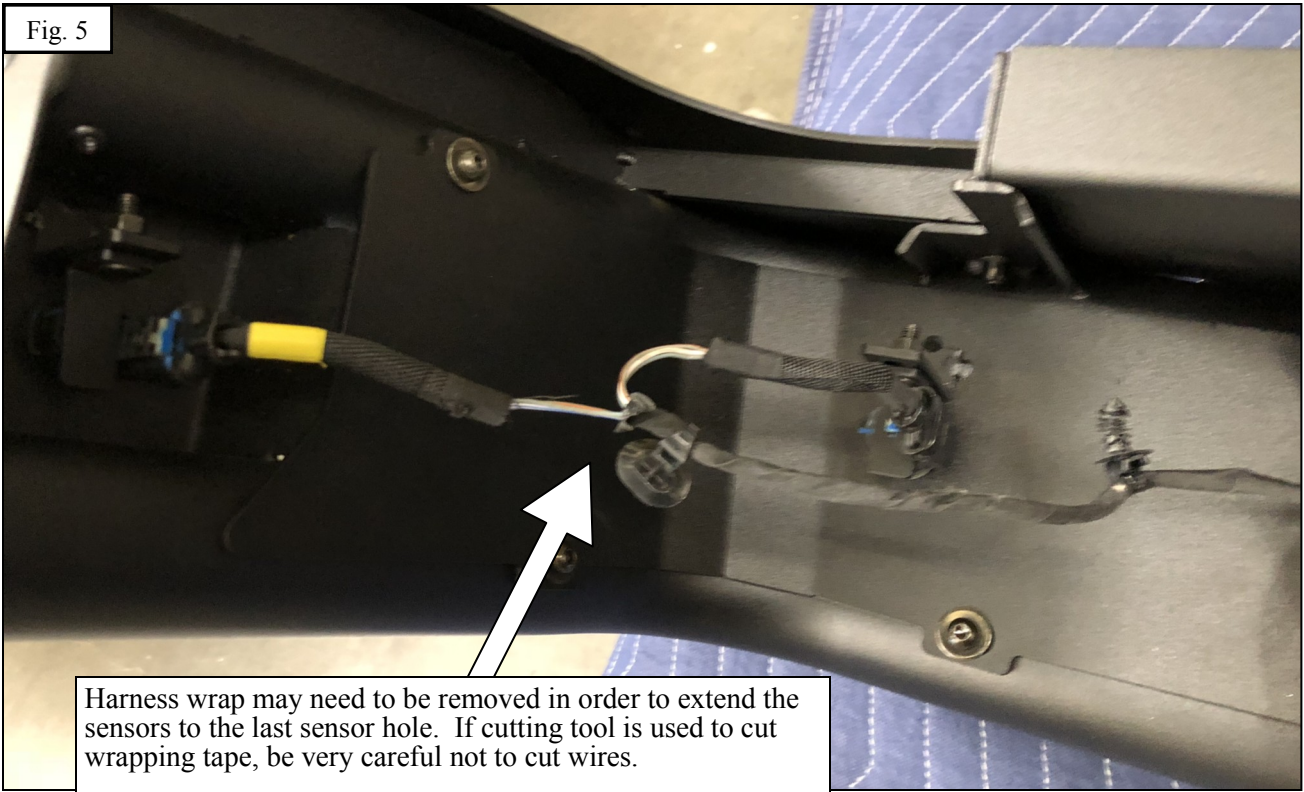

Fig. 5



Harness wrap may need to be removed in order to extend the sensors to the last sensor hole. If cutting tool is used to cut wrapping tape, be very careful not to cut wires.

9. **If blind spot monitor is equipped**– Remove the blind spot monitor from the OE bumper. Remove the cover on the outlaw bumper and install the monitor. See Figure 6-7  
**If blind spot monitor is not equipped**- Leave cover attached on bumper and proceed to the next step.

Figure 6

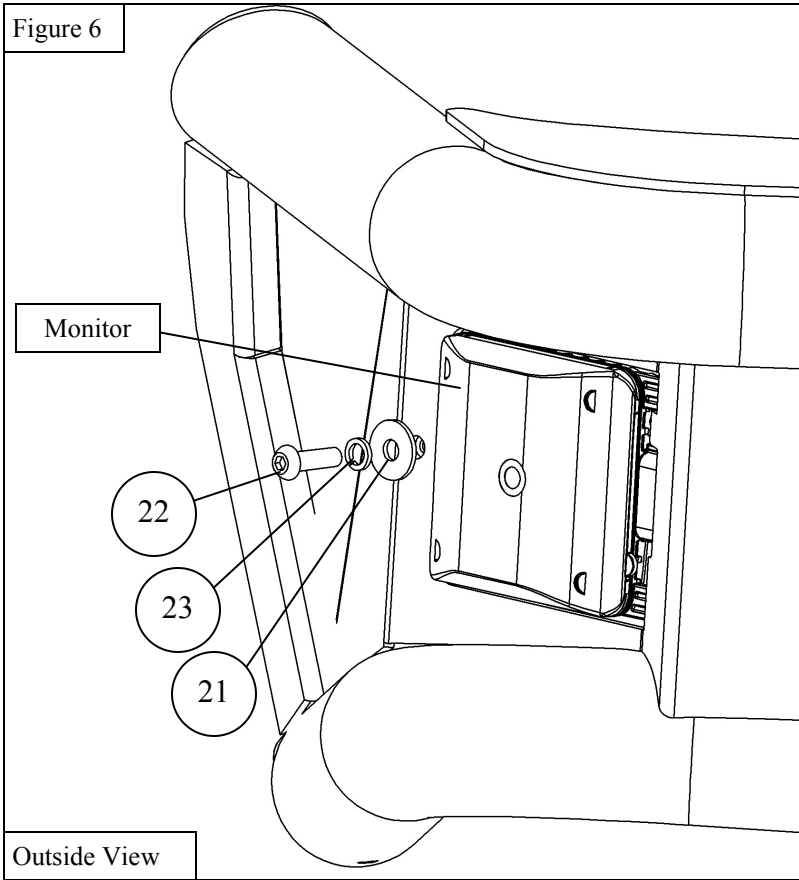

Outside View

Figure 7

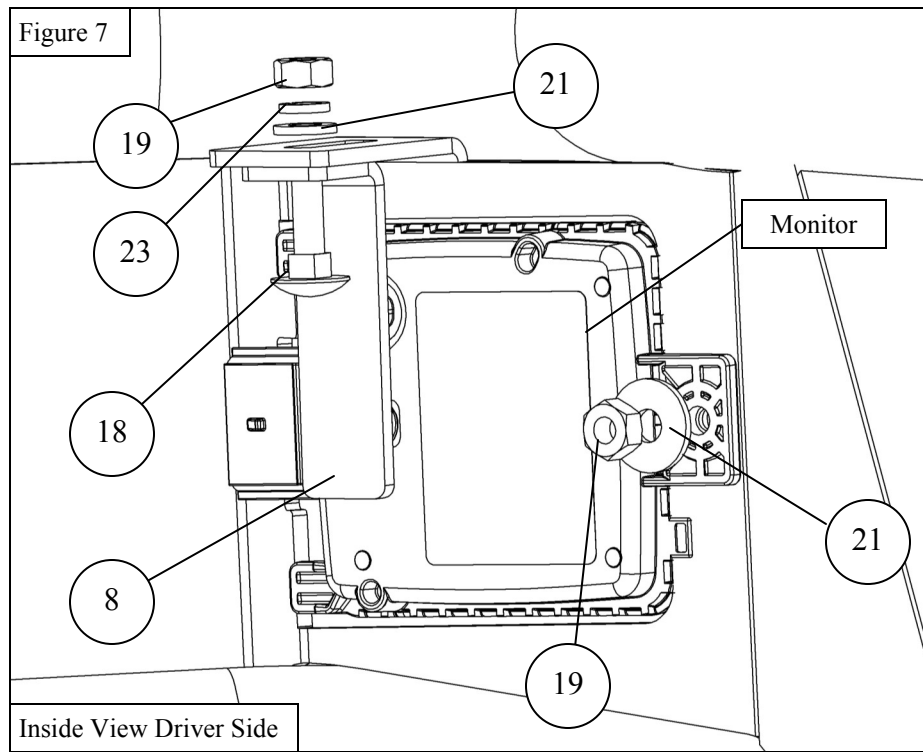

Inside View Driver Side



10. There is a control module that must be tied up to be put out of the way. Use the supplied Zip ties to tie the module to the wire harness.
11. **If you are installing a Westin tow hitch**– You will not be using the supplied mounting brackets in the kit. Instead, the Westin Tow hitch will bolt on to the bumper. Follow the Tow hitch instructions for installation.  
**If you are not installing a Westin tow hitch**- Using the supplied M12 hardware, loosely assemble the mounting brackets to the frame. Use the outermost holes for the 1500 frame. **See Figure 8**

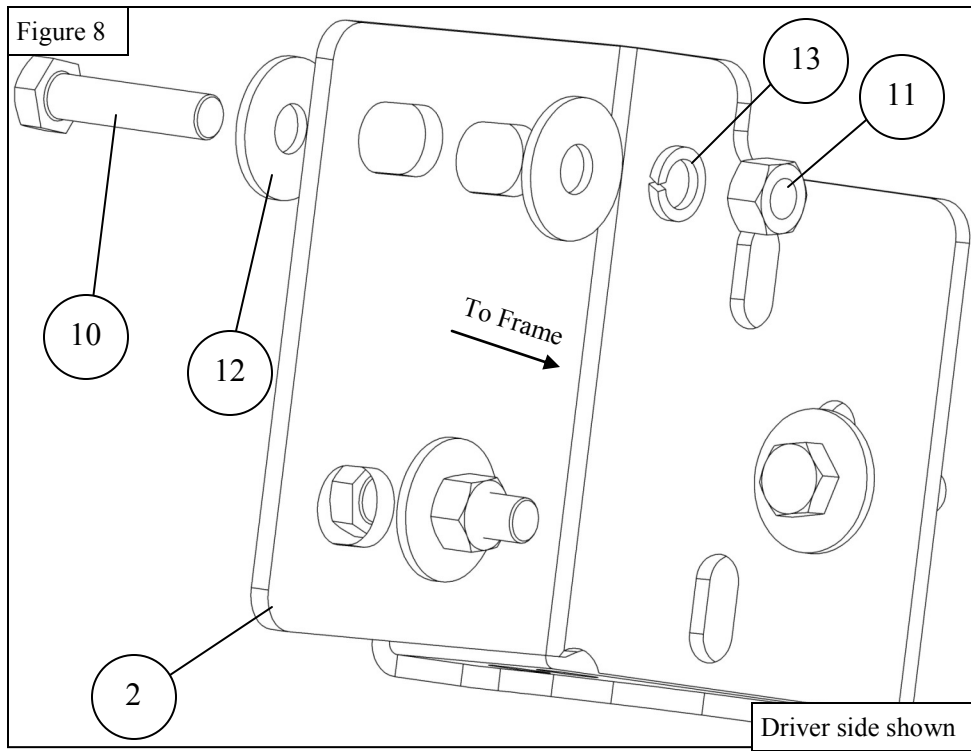

12. Using supplied M12 Hardware, loosely install the rear bumper on to the mounting bracket or tow hitch. **See Figure 9-10**

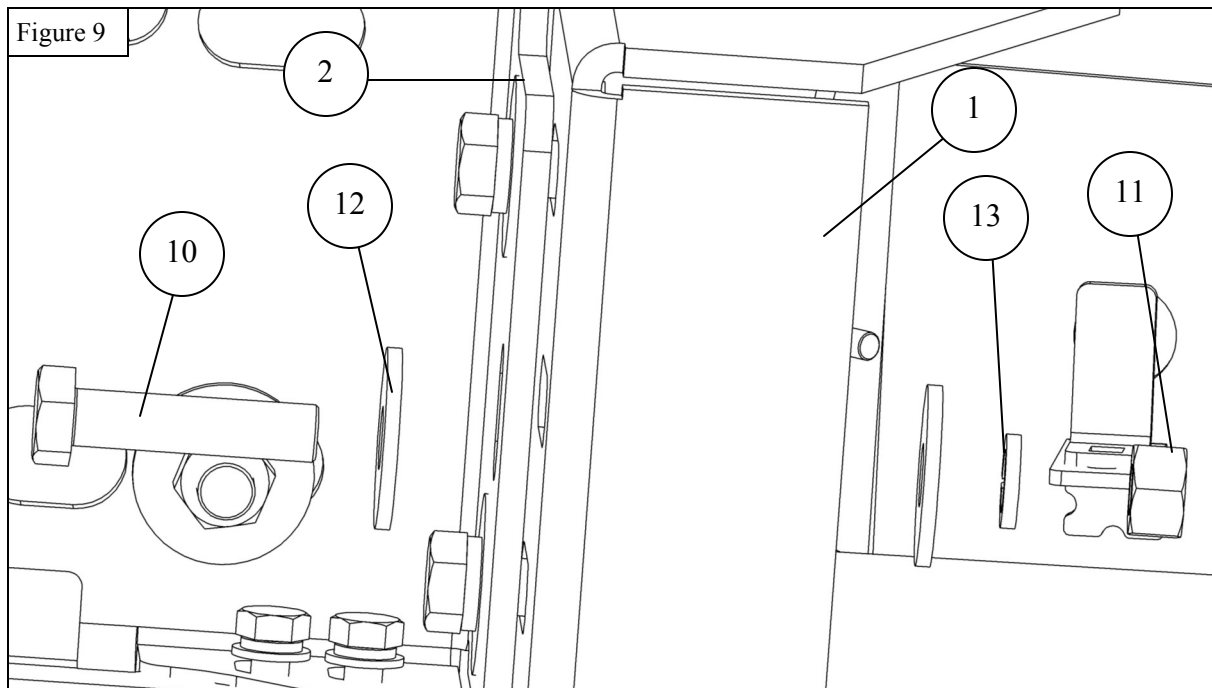
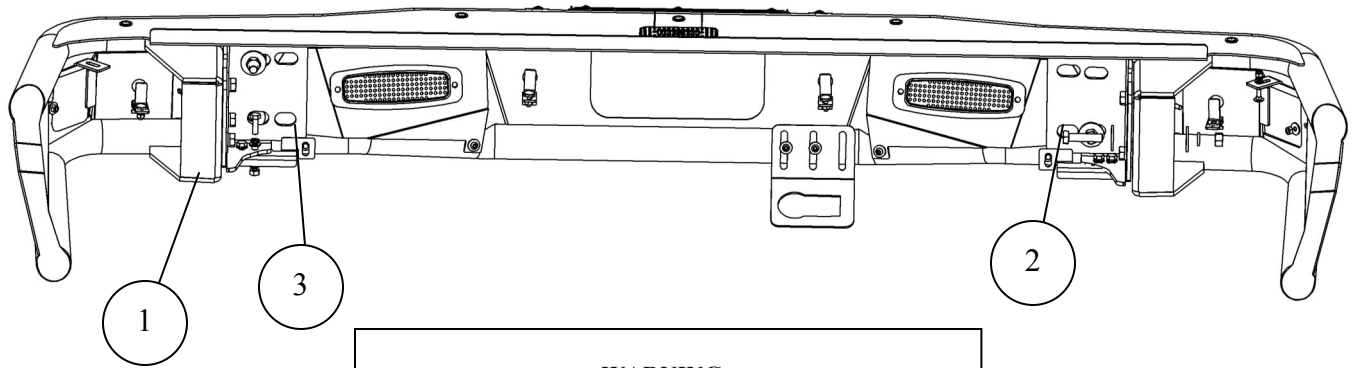
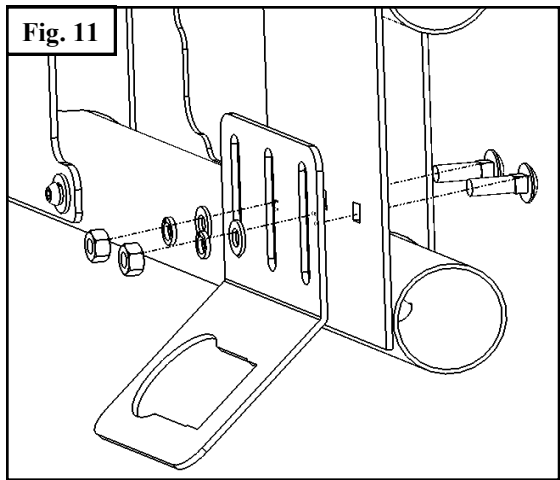

Figure 10



**WARNING .**  
After you have mounted bumper on main brackets. **CAREFULLY** open tailgate. While tailgate is open, adjust the height of the bumper so that it has about 3/8" of clearance with respect to the tailgate. Then, tighten all M12 hardware to 50-55 ft-lbs.

13. Using M8 hardware, install trailer connector bracket (7) to the back plate of the bumper. Adjust up and down as desired and tighten M8 hardware to 15-18 ft-lbs. See **Figure 11**.



14. Using M6 SEMS button head hardware (22-24), install license plate swing mount (29) on bumper. Tighten M6 hardware to 5-7 ft-lbs. See **Figure 12**.
15. Install license plate on the swing mount using M6 SEMS button head hardware and tighten to 5-7 ft-lbs.
16. Tighten the two nylon lock nuts on the sides until it has just enough resistance to prevent rotation due to normal condition while still allowing rotation by hand when desired or needed to access hitch.

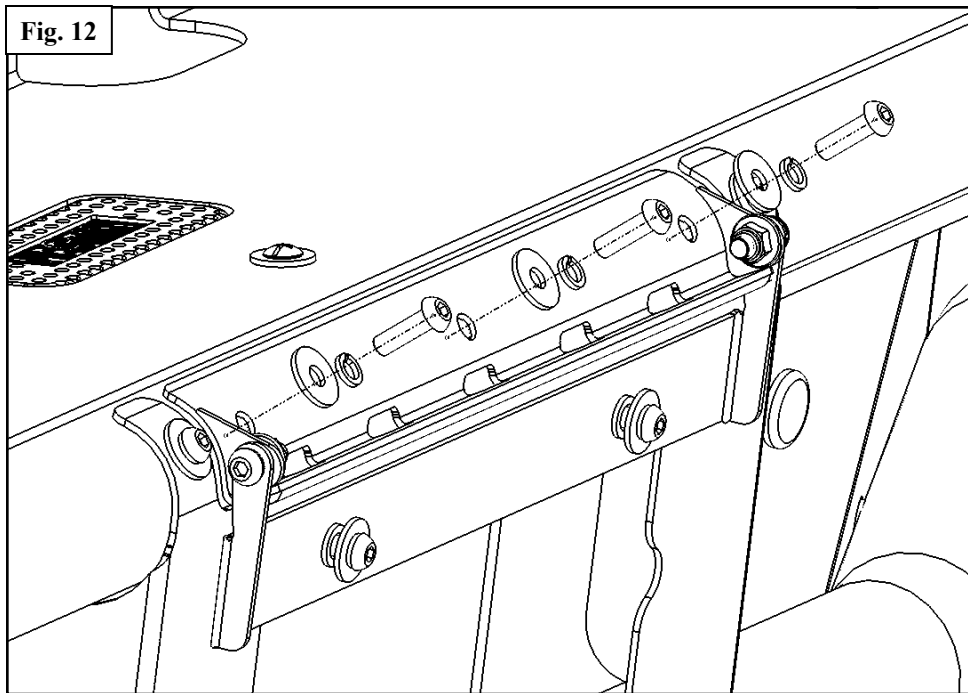

17. Using items 27 and 28 connect the LED license plate light to one of the OEM license plate lights. Connect the black cable from the LED tape to the black cable going into the OEM license plate light. Then, connect the red cable on the LED tape to the colored (non-black) cable going to the OEM license plate light. Crimp carefully and cover with electrical tape. Use supplied zip ties and zip tie mounts to position cables as desired.

18. Mount the exhaust tips to the mounting brackets provided using supplied M8 hardware. See Figures 13-14

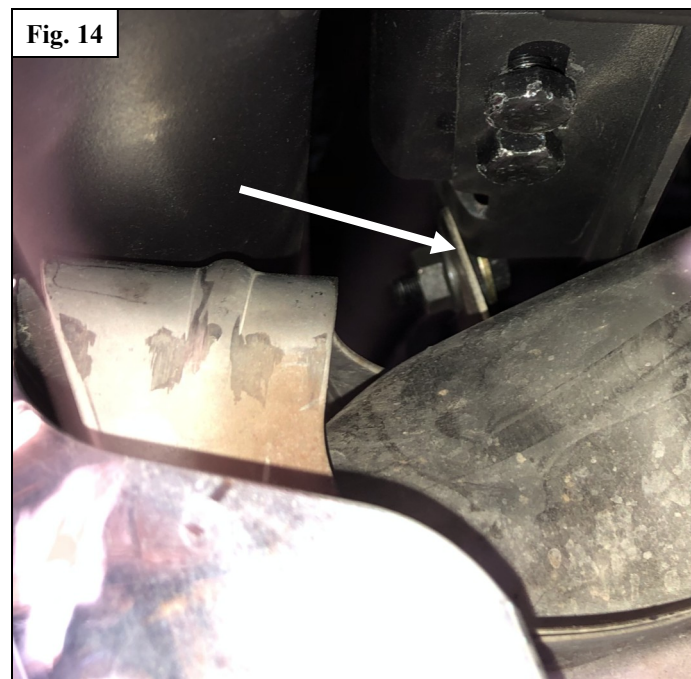
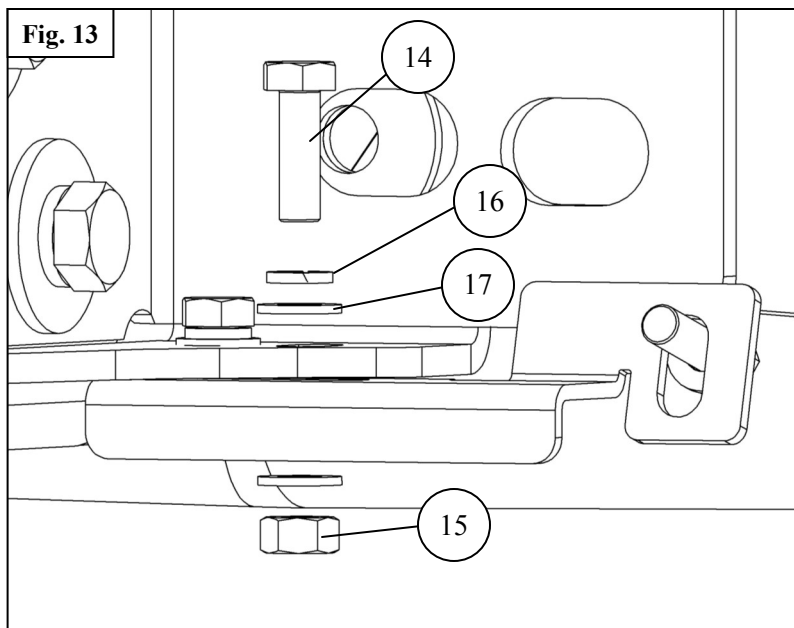



**INSTALLATION COMPLETE**



**CARE INSTRUCTIONS**

- REGULAR WAXING IS RECOMMENDED. DO NOT USE ANY TYPE OF POLISH OR WAX THAT MAY CONTAIN ABRASIVES.
- STAINLESS STEEL PRODUCTS CAN BE CLEANED WITH MILD SOAP AND WATER. STAINLESS STEEL POLISH SHOULD BE USED TO POLISH SMALL SCRATCHES.
- GLOSS BLACK FINISHES SHOULD BE CLEANED WITH MILD SOAP AND WATER.

**WESTIN**



## WARNING



Failure to follow these instructions could lead to death, personal injury, and / or property damage.

Failure to follow these instructions could lead to death, personal injury, and / or property damage.

### FASTENERS:

All Westin supplied fasteners must be utilized and installed in accordance with the installation instructions and apply torque to the specifications as defined. **DOUBLE CHECK ALL FASTENERS BEFORE INITIAL USE, AND PERIODICALLY IN THE FUTURE TO ENSURE PROPER FUNCTION AND SAFETY.**

### DRILLING:

Most Westin products do not require drilling for installation. If drilling is defined as required, use caution when drilling a vehicle. **FAILURE TO REVIEW AN AREA TO BE DRILLED MAY RESULT IN PERSONAL INJURY AND/OR INJURY TO OTHERS AS WELL AS VEHICLE DAMAGE.**

### EYE PROTECTION:

**ALWAYS WEAR SAFETY GLASSES OR GOGGLES DURING THE INSTALLATION PROCESS TO AVOID PERSONAL INJURY.**

### MAXIMUM TOWING/CARRYING CAPACITY: (if applicable)

The Westin Receiver Hitches will have a visible tow rating label affixed directly on the product. User should never exceed the vehicle manufacturers maximum tow and weight rating regardless of the capacity of the hitch. **FAILURE TO FOLLOW THESE GUIDELINES WILL VOID THE WESTIN WARRANTY AND MAY RESULT IN PERSONAL INJURY AND/OR INJURY TO OTHERS AS WELL AS VEHICLE DAMAGE.**

### FOR CALIFORNIA RESIDENTS ONLY-PROP 65 WARNING:

Some products may contain chemicals such as DEHP, which can cause cancer, birth defects or other reproductive harm.



Learn more about off-road bumpers we have.