

# INSTALLATION INSTRUCTIONS

## PRO-MOD SKID PLATE

# WESTiN®

**APPLICATION:**  
2014-2019 Toyota Tundra  
**PART NUMBER:**  
58-72015

CONTENT			
ITEM	QUANTITY	DESCRIPTION	TOOLS NEEDED
1	1	SKID PLATE	13MM SOCKET
2	4	M8 U-CLIP (YELLOW ZINC)	16MM WRENCH
3	4	M2 HEX HEAD BOLT (YELLOW ZINC)	RATCHET
4	4	M12 FLAT WASHER (YELLOW ZINC)	TORQUE WRENCH
5	6	M8 BUTTON HEAD BOLT (BLACK ZINC)	
6	8	M8 FLAT WASHER (BLACK ZINC)	
7	6	M8 SPLIT LOCK WASHER (BLACK ZINC)	
8	2	M8 SERRATED FLANGE NUT (BLACK ZINC)	

**ANTI-SEIZE LUBRICANT MUST BE USED ON ALL STAINLESS STEEL FASTENERS TO PREVENT THREAD DAMAGE AND GALLING**

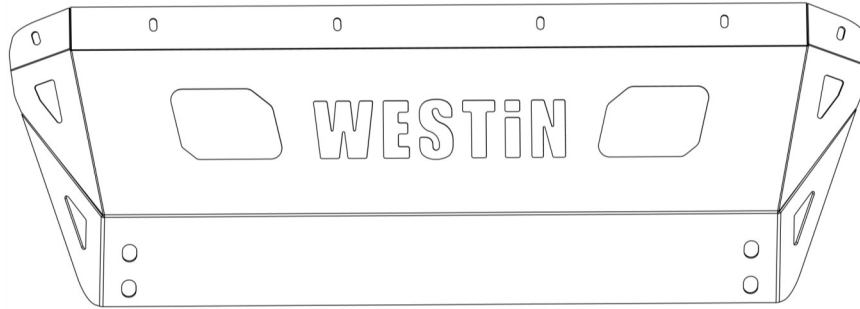

ITEM 1

## PROCEDURE

1. Remove contents from box, verify if all parts listed are present and free from damage.  
Carefully read and understand all instructions before attempting installation.  
**Failure to identify damage before installation could lead to a rejection of any claim.**
2. Attach the M8 U-Clips (2) to the pre-installed Pro-Mod Bumper (sold separately) in the locations shown in **Figure 1**.

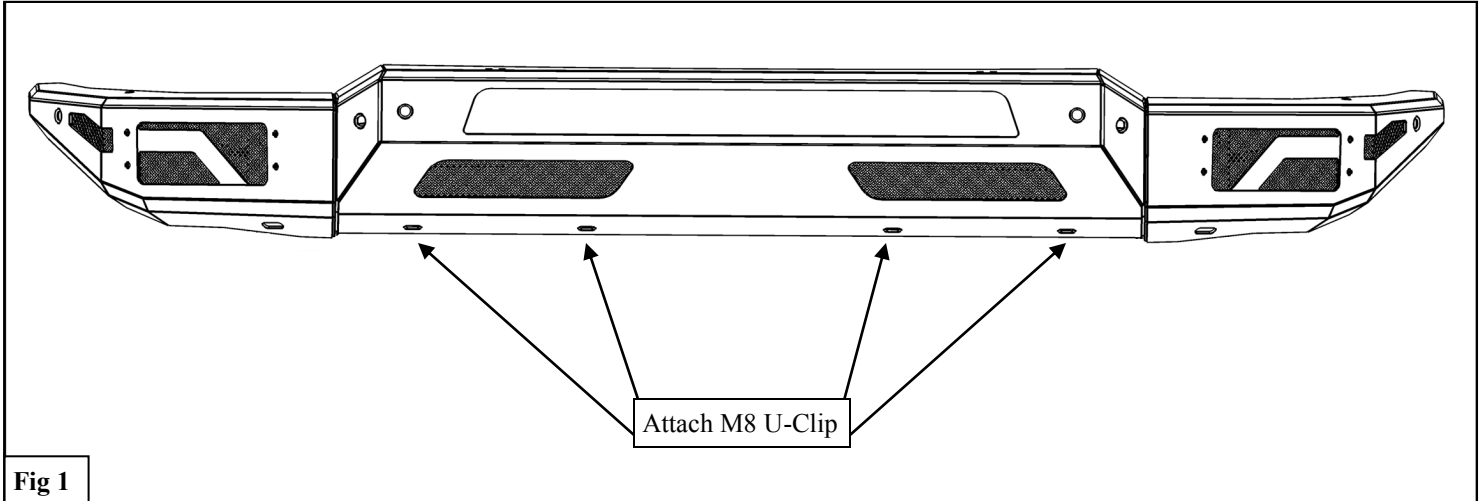

3. Remove the factory tow hooks, as these will also be used by the Skid plate. See **Figure 3**
4. Lift the Skid Plate (1) into place and secure it using the supplied M8 and M12 Hardware. *Note: Be sure to re-attach factory tow hooks after loosely mounting skid plate with M8 hardware.* See **Figures 2-4**.

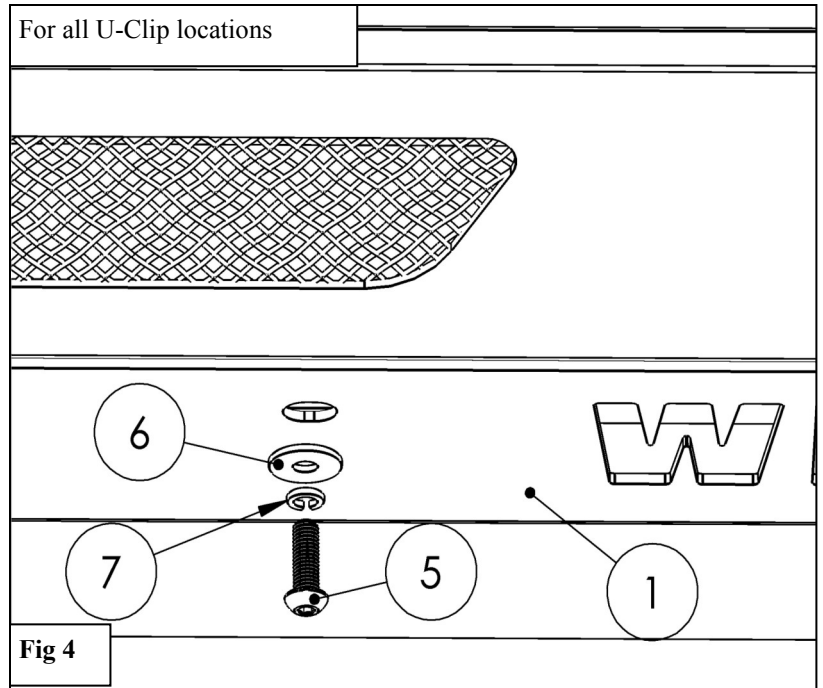
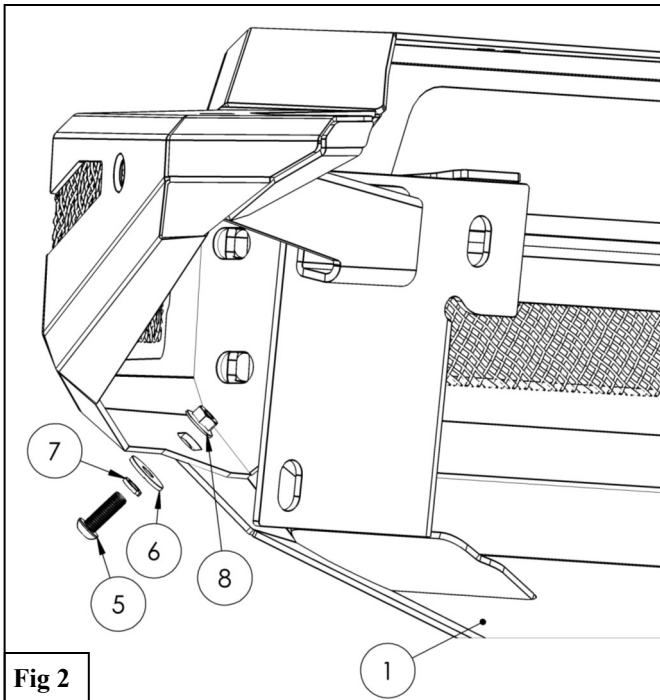



**Fig 3**

Remove factory tow hooks, then attach skid plate. Then re-attach factory tow hooks using supplied M12 hardware or OEM hardware.

5. Align and tighten all hardware as specified: M8 to 18 ft-lbs, M12 to 65 ft-lbs.

#### CARE INSTRUCTIONS

- REGULAR WAXING IS RECOMMENDED. DO NOT USE ANY TYPE OF POLISH OR WAX THAT MAY CONTAIN ABRASIVES.
- STAINLESS STEEL PRODUCTS CAN BE CLEANED WITH MILD SOAP AND WATER. STAINLESS STEEL POLISH SHOULD BE USED TO POLISH SMALL SCRATCHES.
- GLOSS BLACK FINISHES SHOULD BE CLEANED WITH MILD SOAP AND WATER



INSTALLATION COMPLETE



©2019 WESTIN AUTOMOTIVE PRODUCTS, INC. ALL RIGHTS RESERVED

Bumper and Lights sold separately



## WARNING



Failure to follow these instructions could lead to death, personal injury, and / or property damage.

Failure to follow these instructions could lead to death, personal injury, and / or property damage.

### FASTENERS:

All Westin supplied fasteners must be utilized and installed in accordance with the installation instructions and apply torque to the specifications as defined. **DOUBLE CHECK ALL FASTENERS BEFORE INITIAL USE, AND PERIODICALLY IN THE FUTURE TO ENSURE PROPER FUNCTION AND SAFETY.**

### DRILLING:

Most Westin products do not require drilling for installation. If drilling is defined as required, use caution when drilling a vehicle. **FAILURE TO REVIEW AN AREA TO BE DRILLED MAY RESULT IN PERSONAL INJURY AND/OR INJURY TO OTHERS AS WELL AS VEHICLE DAMAGE.**

### EYE PROTECTION:

**ALWAYS WEAR SAFETY GLASSES OR GOGGLES DURING THE INSTALLATION PROCESS TO AVOID PERSONAL INJURY.**

### MAXIMUM TOWING/CARRYING CAPACITY: (if applicable)

The Westin Receiver Hitches will have a visible tow rating label affixed directly on the product. User should never exceed the vehicle manufacturers maximum tow and weight rating regardless of the capacity of the hitch. **FAILURE TO FOLLOW THESE GUIDELINES WILL VOID THE WESTIN WARRANTY AND MAY RESULT IN PERSONAL INJURY AND/OR INJURY TO OTHERS AS WELL AS VEHICLE DAMAGE.**

