

INSTALLATION INSTRUCTIONS

Outlaw Bumper Skid Plate



APPLICATION:
2016-2018 Chevrolet Silverado 1500
PART NUMBER:
58-71005

CONTENT			
ITEM	QUANTITY	DESCRIPTION	TOOLS NEEDED
1	1	UPPER SKID PLATE	17MM SOCKET
2	1	LOWER SKID PLATE	RATCHET
3,4	2	SUPPORT TUBE, DRIVER (3) AND PASSENGER (4)	TORQUE WRENCH
5	1	CROSSMEMBER BRACKET	5MM ALLEN
6	1	M10 NUT PLATE	13MM SOCKET
7	1	M10 SPLIT LOCK WASHER	10MM SOCKET
8	7	M10 FLAT WASHER	15MM SOCKET
9	7	M10 HEX BOLT	
10	6	M10 SERRATED FLANGE NUT	
11	10	M8 BUTTON HEAD BOLT	
12	10	M8 FLAT WASHER	
13	10	M8 SPLIT LOCK WASHER	
14	10	M8 U-CLIP	
ANTI-SEIZE LUBRICANT MUST BE USED ON ALL STAINLESS STEEL FASTENERS TO PREVENT THREAD DAMAGE AND GALLING			

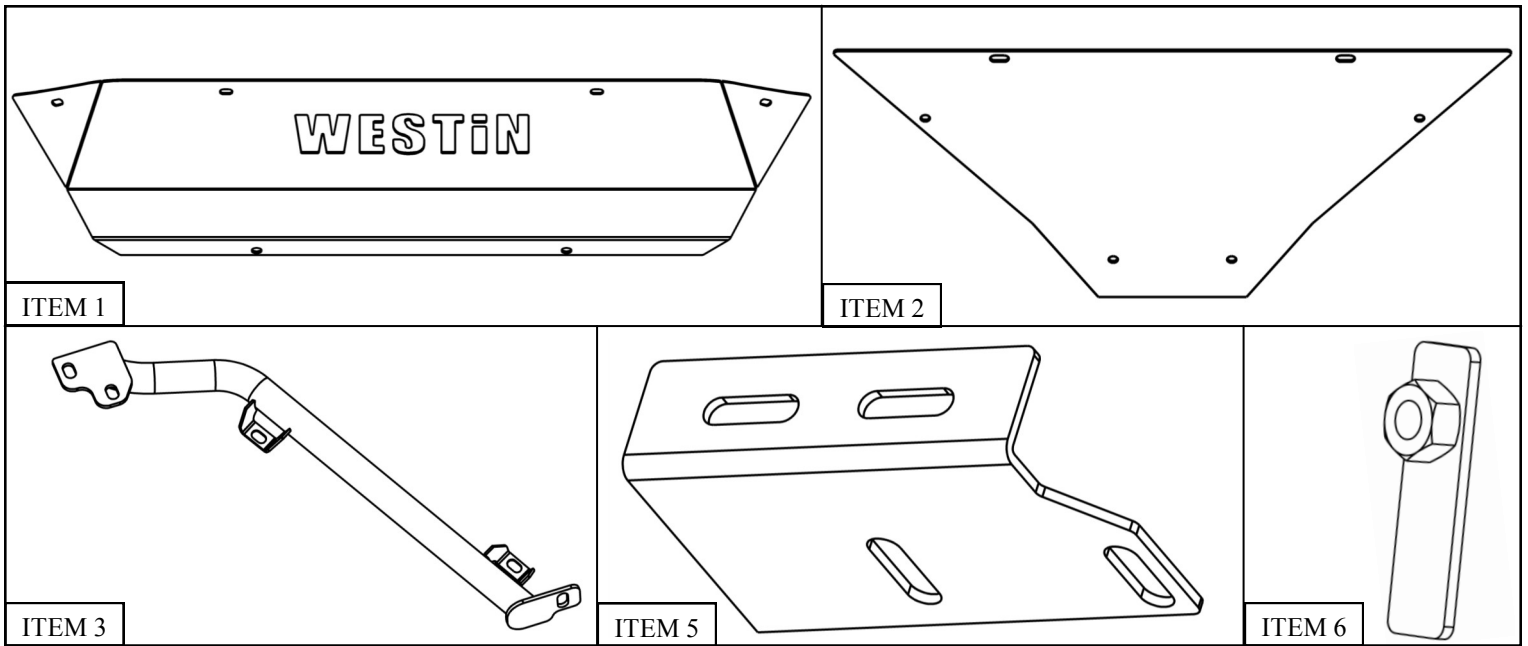

PROCEDURE

1. Remove contents from box, verify if all parts listed are present and free from damage.
Carefully read and understand all instructions before attempting installation.
Failure to identify damage before installation could lead to a rejection of any claim.

2. Remove plastic cover on the underside of the vehicle. See **Figures 1 & 2**.
3. Remove the two brackets shown in **Figure 3** saving the bolt and hardware indicated in **Figure 3**.

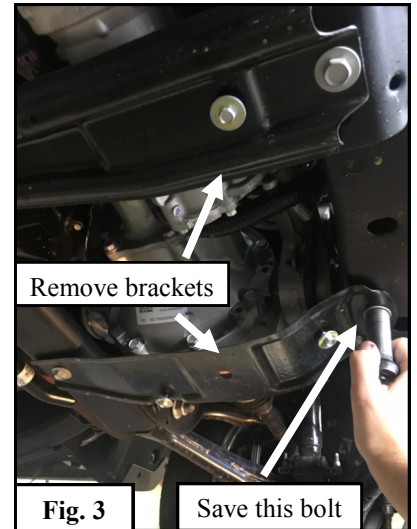
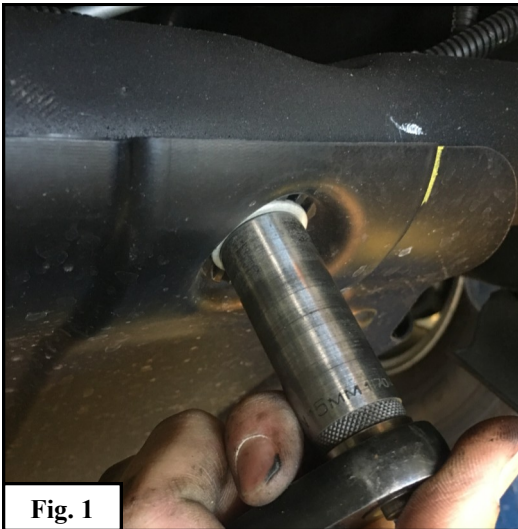

4. Insert the M10 nut plate (6) into the frame crossmember and loosely install the crossmember bracket (5) using the hardware saved in step 3 and the supplied M10 hardware (7-9). See **Figure 4**.

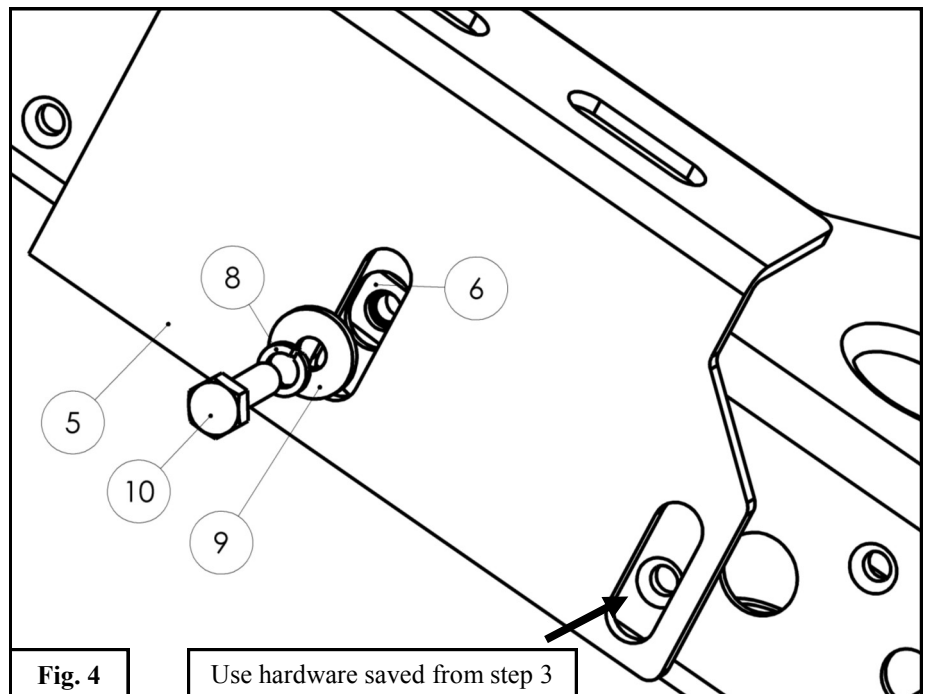

5. Loosely install the support tubes (3 & 4) using the supplied M10 hardware (8-10) according to **Figures 5-7**. *Note:* Driver's side shown in figures 5-7.

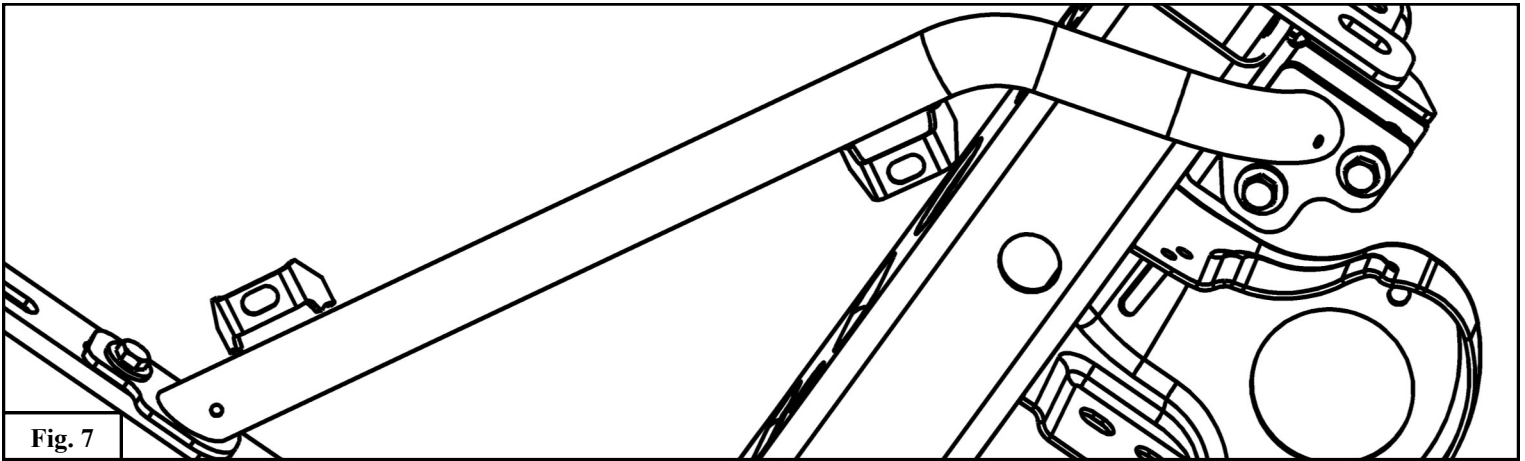
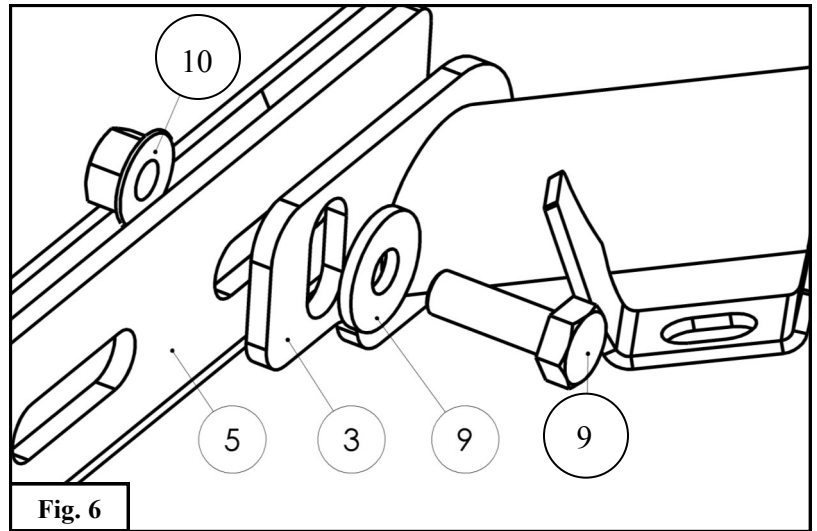
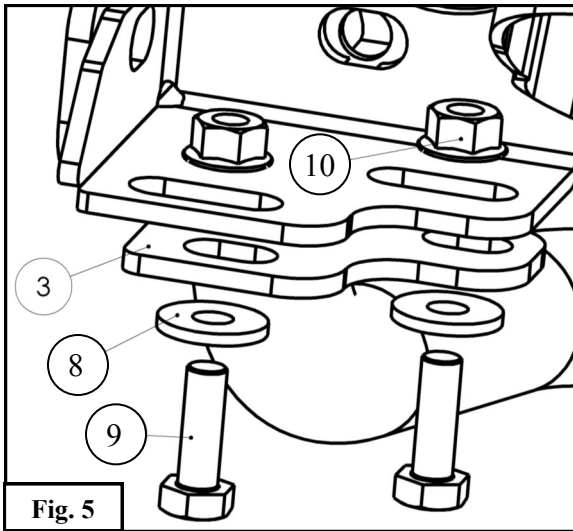

6. Tighten all M10 hardware to 30-35 ft-lbs.
7. Install four M8 U-clips (15) onto the tabs welded to the front bumper assembly according to **Figure 8**.

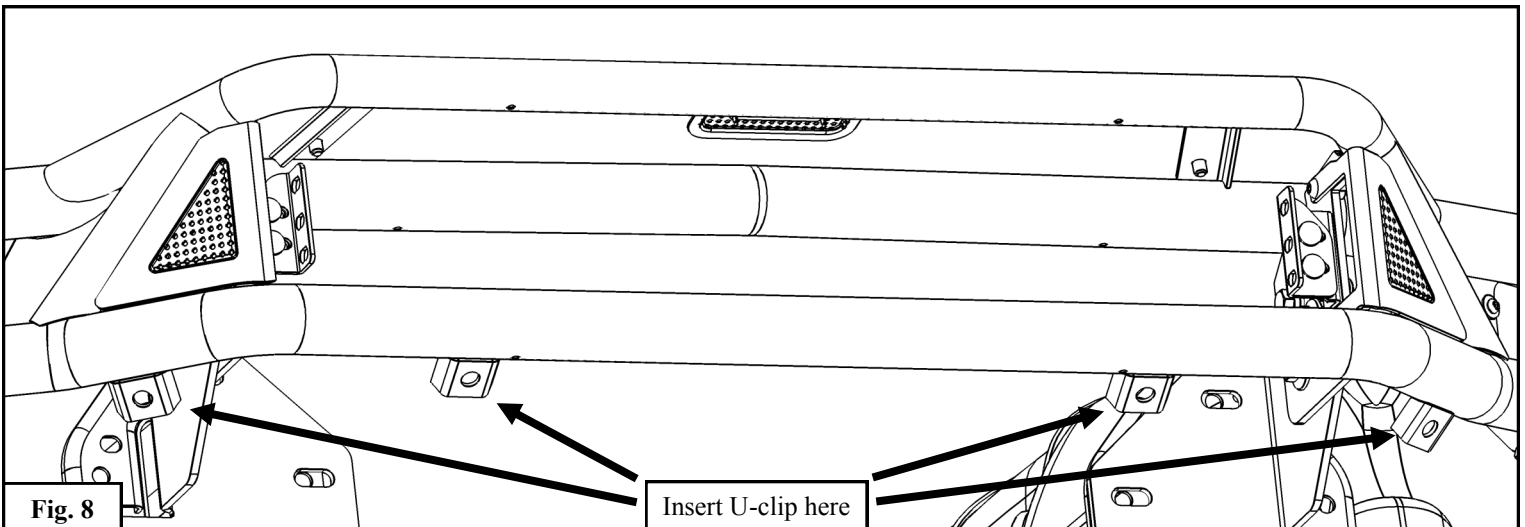

8. Loosely install the upper skid plate (1) using the supplied M8 hardware (12-14) according to **Figures 9 & 10**.

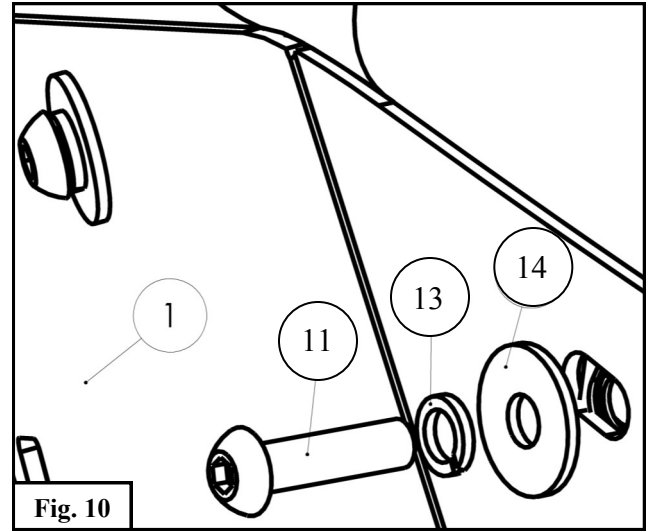
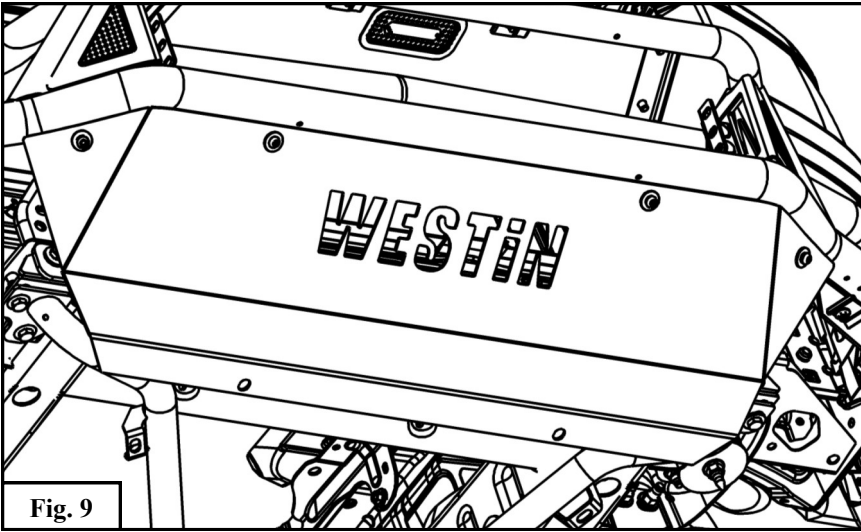

9. Install M8 U-clips (14) on the upper skid plate (1) and tabs welded to the support tubes (3 & 4) using the supplied M8 hardware (11-13) according to **Figure 11**.

10. Loosely install the lower skid plate (2) using the supplied M8 hardware (11-13) so that the front of the lower skid plate is between the support tubes and the upper skid plate. See **Figure 12**. *Note:* Hardware configuration is the same as step 7.

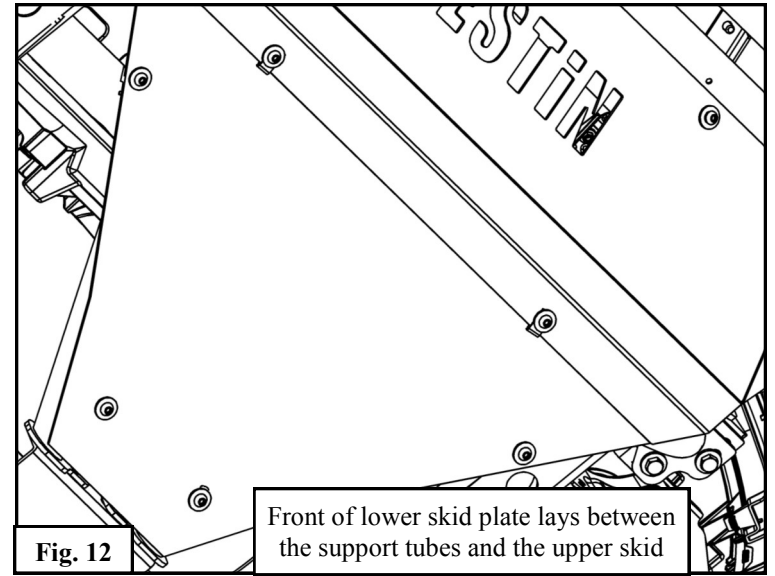
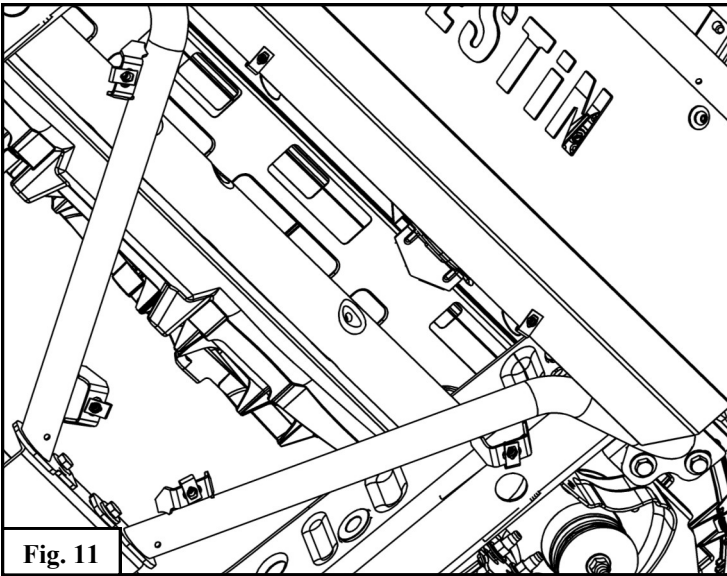

11. Tighten all M8 hardware to 15-18 ft-lbs.

INSTALLATION COMPLETE



CARE INSTRUCTIONS

- REGULAR WAXING IS RECOMMENDED. DO NOT USE ANY TYPE OF POLISH OR WAX THAT MAY CONTAIN ABRASIVES.
- STAINLESS STEEL PRODUCTS CAN BE CLEANED WITH MILD SOAP AND WATER. STAINLESS STEEL POLISH SHOULD BE USED TO POLISH SMALL SCRATCHES.
- GLOSS BLACK FINISHES SHOULD BE CLEANED WITH MILD SOAP AND WATER.

WESTIN