

# INSTALLATION INSTRUCTIONS

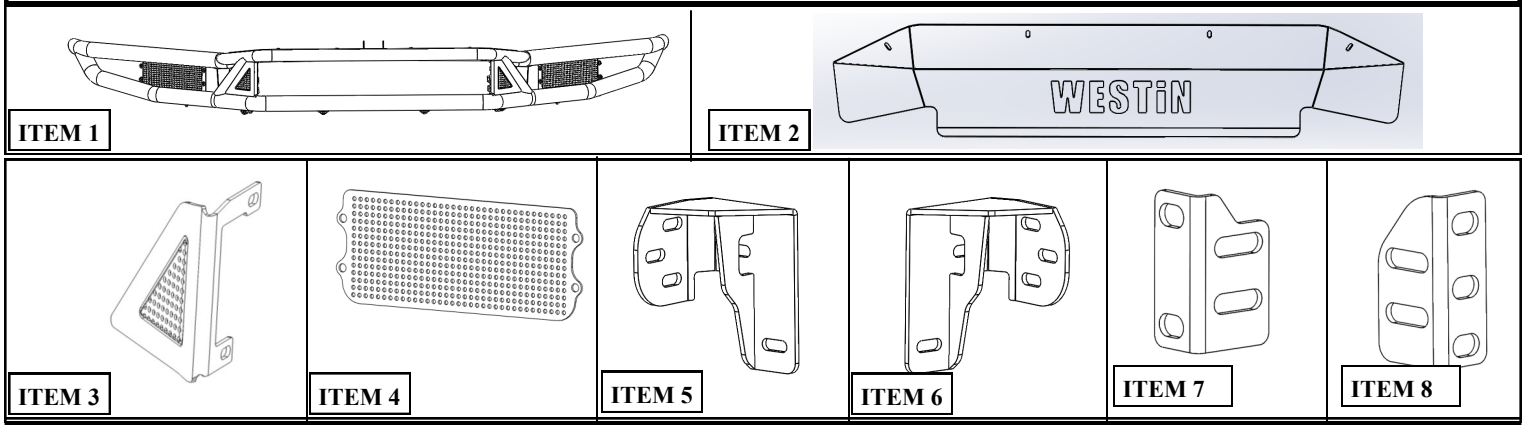
## OUTLAW FRONT BUMPER



**APPLICATION:**  
2017-2019 Ford F-150 Raptor  
**PART NUMBER:**  
58-62025

<b>CONTENT</b>			
ITEM	QUANTITY	DESCRIPTION	TOOLS NEEDED
1	1	OUTLAW FRONT BUMPER	13MM SOCKET
2	1	UPPER SKID PLATE	RATCHET
3	2	CORNER MESH COVER	TORQUE WRENCH
4	2	LED MESH COVER	13MM WRENCH
5	1	DRIVER FRAME BRACKET	18MM SOCKET
6	1	PASSENGER FRAME BRACKET	18MM WRENCH
7	2	LED SLIDER BRACKET DRIVER, PASSENGER	PRY TOOL
8	2	LED L-BRACKET DRIVER, PASSENGER	
9	1	LOGO PLATE	
10	4	M8 U CLIPS	
11	10	M12 HEX HEAD BOLT	
12	10	M12 SERRATED FLANGE NUT	
13	20	M12 FLAT WASHER	
14	10	M12 SPLIT LOCK WASHER	
15	8	M8 ROUND HEAD SQUARE NECK BOLT	
16	8	M8 HEX NUT	
17	12	SMALL M8 FLAT WASHER	
18	4	M8 SERRATED FLANGE NUT	
19	4	M8 BUTTON HEAD BOLT SHORT	
20	12	M8 SPLIT LOCK WASHER	
21	4	M8 BUTTON HEAD BOLT LONG	
22	4	LARGE M8 FLAT WASHER	

**ANTI-SEIZE LUBRICANT MUST BE USED ON ALL STAINLESS STEEL FASTENERS TO PREVENT THREAD DAMAGE AND GALLING**



## PROCEDURE

1. Remove contents from box, verify if all parts listed are present and free from damage.

Carefully read and understand all instructions before attempting installation.

**Failure to identify damage before installation could lead to a rejection of any claim.**

**Fig. 1**

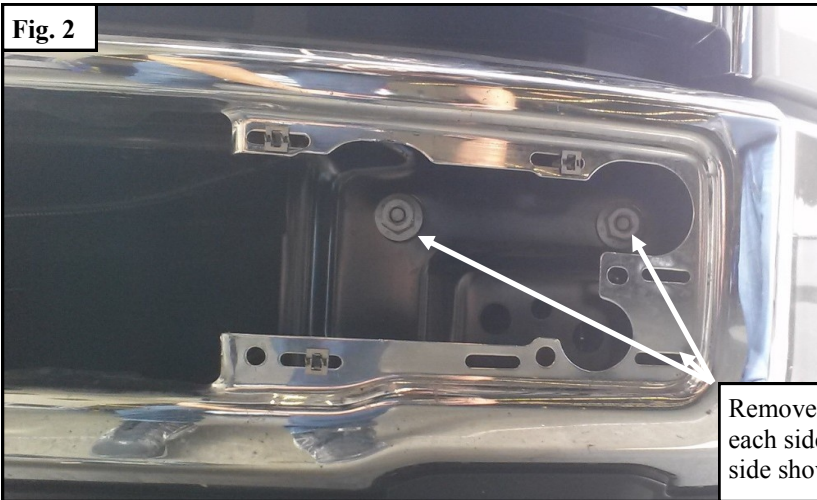


2. Remove plastic caps from stock bumper. See **Figure 1**.

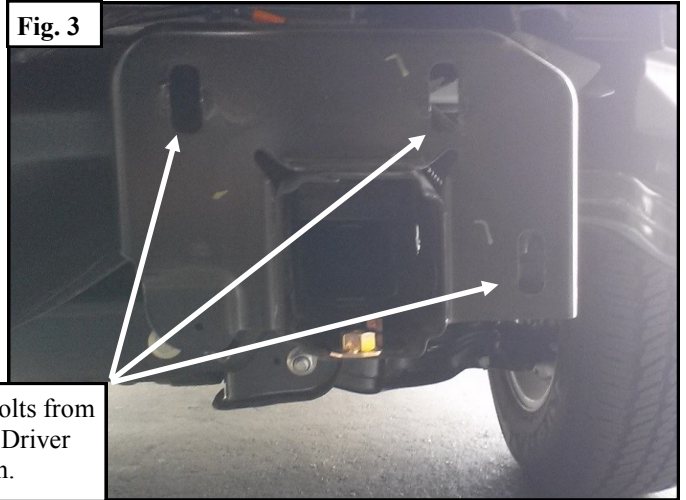
3. Remove the three bolts indicated in **Figures 2 & 3** from each side of the vehicle.

4. Remove original bumper making sure to disconnect any electrical connections to the bumper.

**Fig. 2**

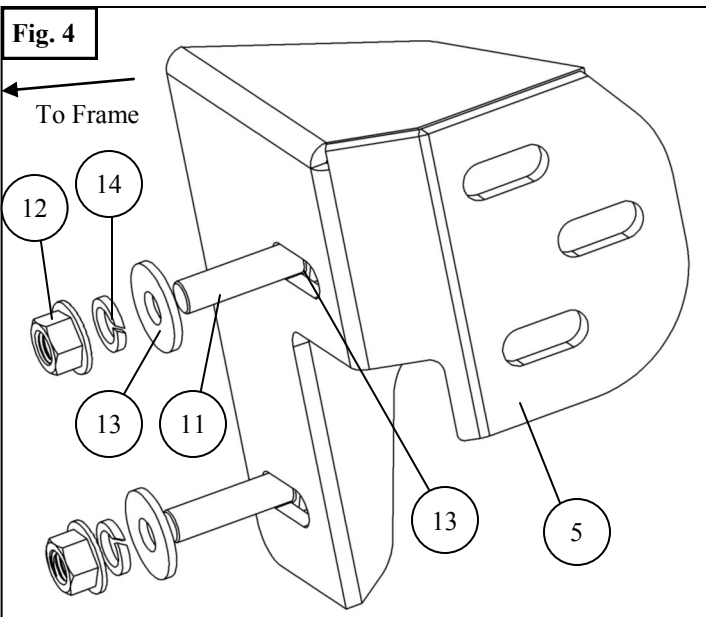


**Fig. 3**



Remove bolts from each side. Driver side shown.

**Fig. 4**

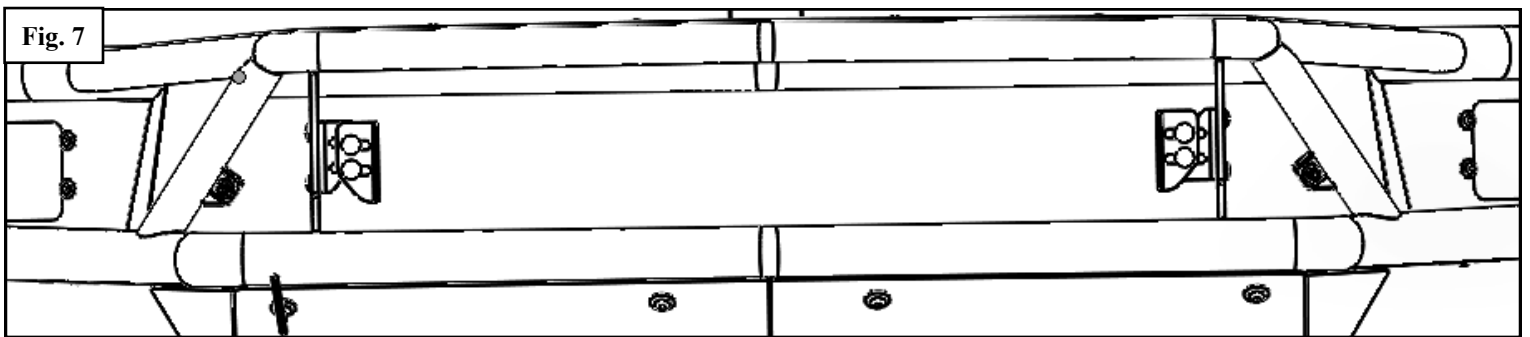
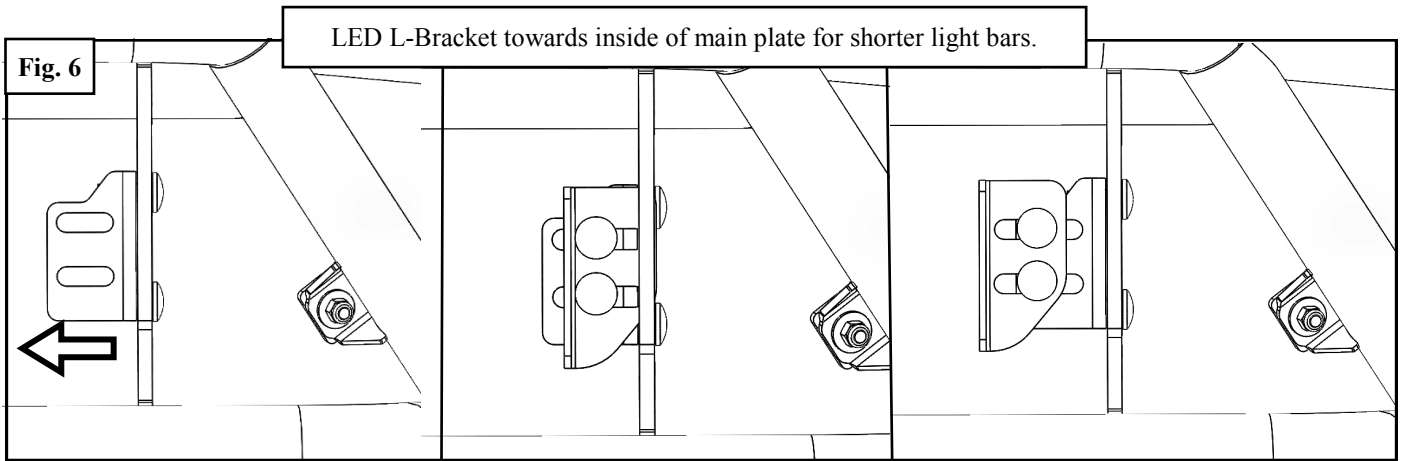
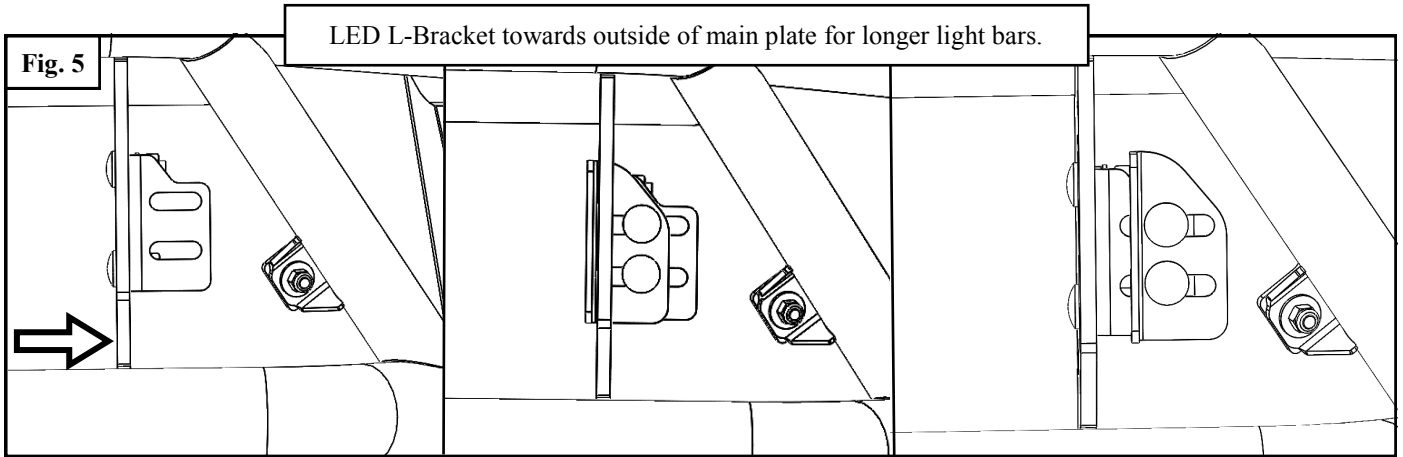


5. Loosely install frame brackets (5 & 6) using the supplied M12 hardware. **Note:** Driver side shown. See **Figure 4**.



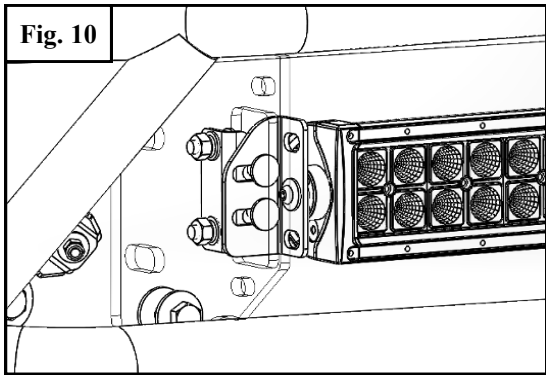
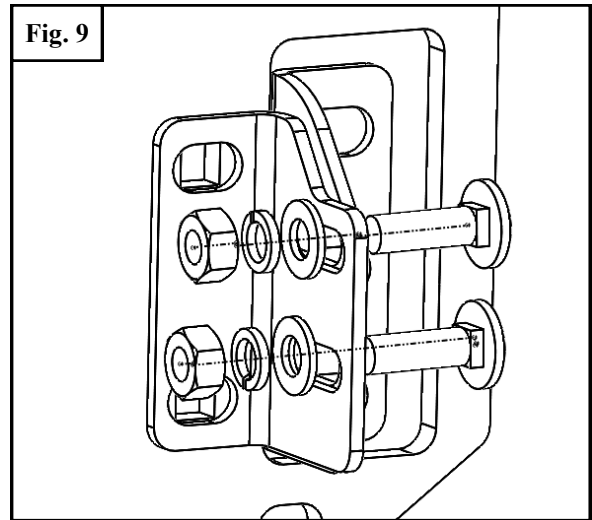
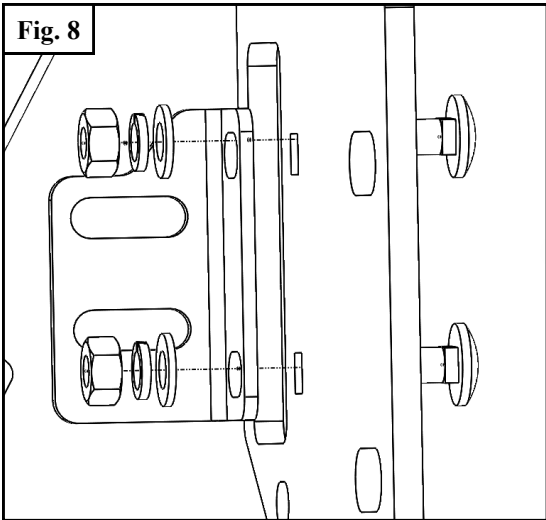
**Note:** If vehicle is equipped with active cruise control (ACC), carefully remove ACC by pulling module firmly from studs and disconnect connector. An ACC re-locator will be needed to use with Outlaw bumper.

6. Proceed to install center light bar brackets (and light bars). Items 7-8 can be mounted in different configurations in order to have the necessary adjustment for various “30” inch light bar overall lengths. See **Figure 5-7**.

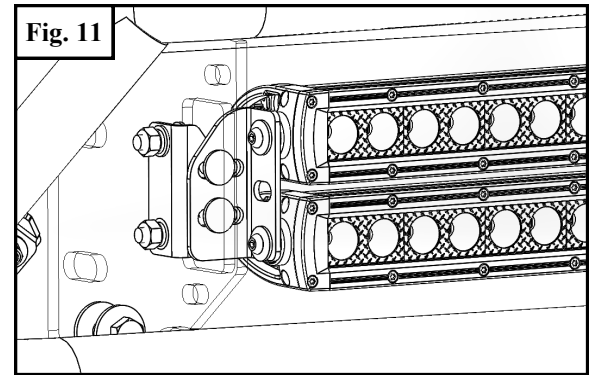


**Figure 7** is an example that shows the LED brackets towards the inside adjusted in for the shortest light bar configuration.

7. Using items 15-17 and 20 fasten LED L-Brackets (Item 8) to main plate. Do not tighten. See **Figure 8**.
8. Using items 15-17, and 20 fasten LED Slider Bracket (Item 7) to LED L-Bracket. Do not tighten. See **Figure 9**.
9. Using hardware included in the LED light bar hardware kit, fasten to bracket according to **Figures 10 & 11**.
10. Position light bar as desired and tighten all M8 hardware to 15-18 ft-lbs.

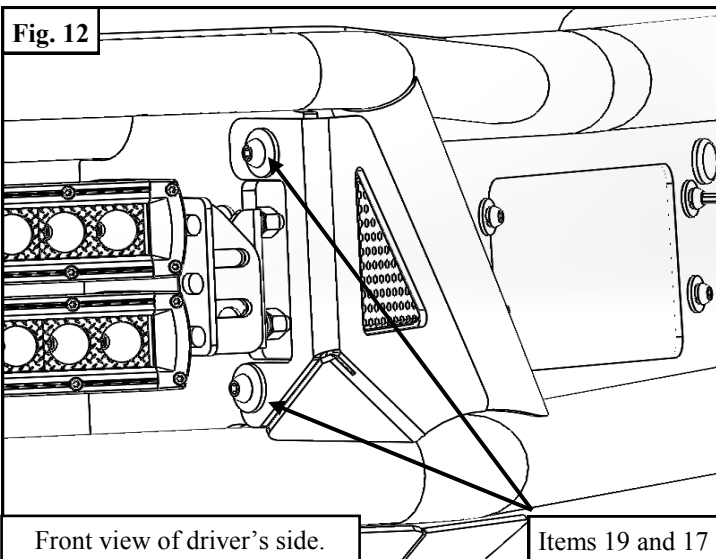


Single "Double Row" Light Bar Configuration



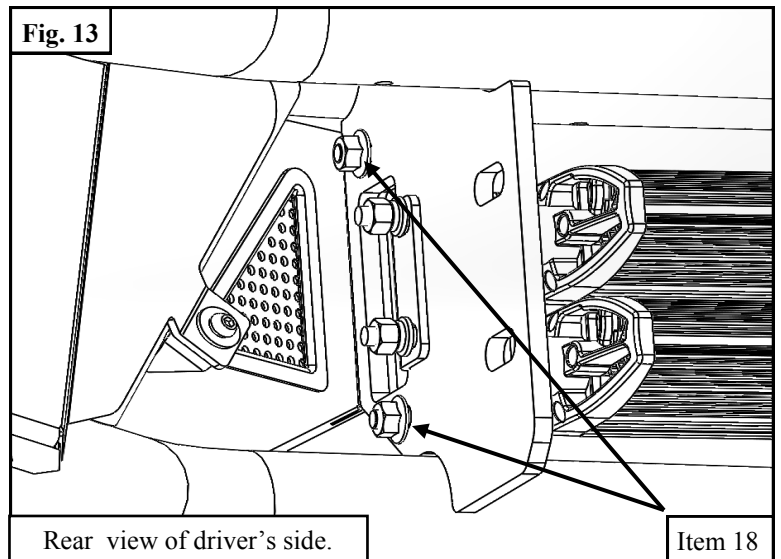
Double "Single Row" Light Bar Configuration

11. Position the meshed corner covers (Item 3) as seen in **Figures 12 & 13**.



Front view of driver's side.

Items 19 and 17

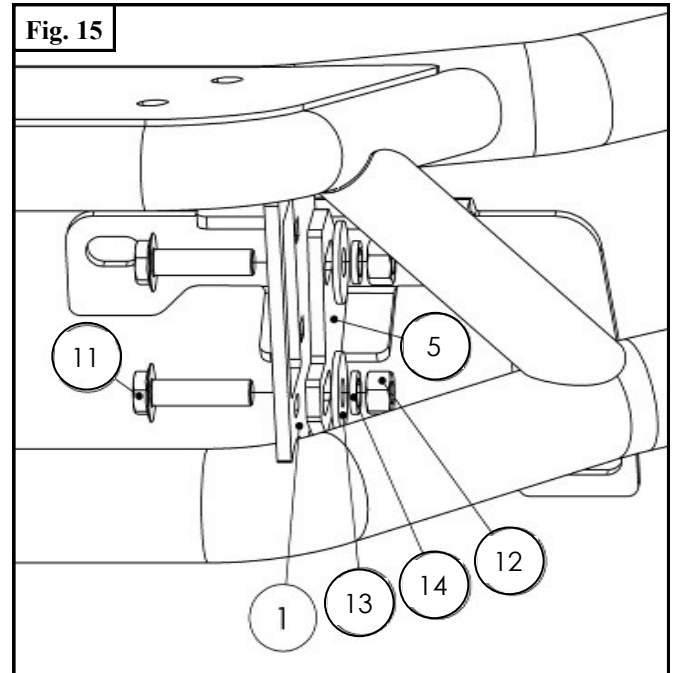
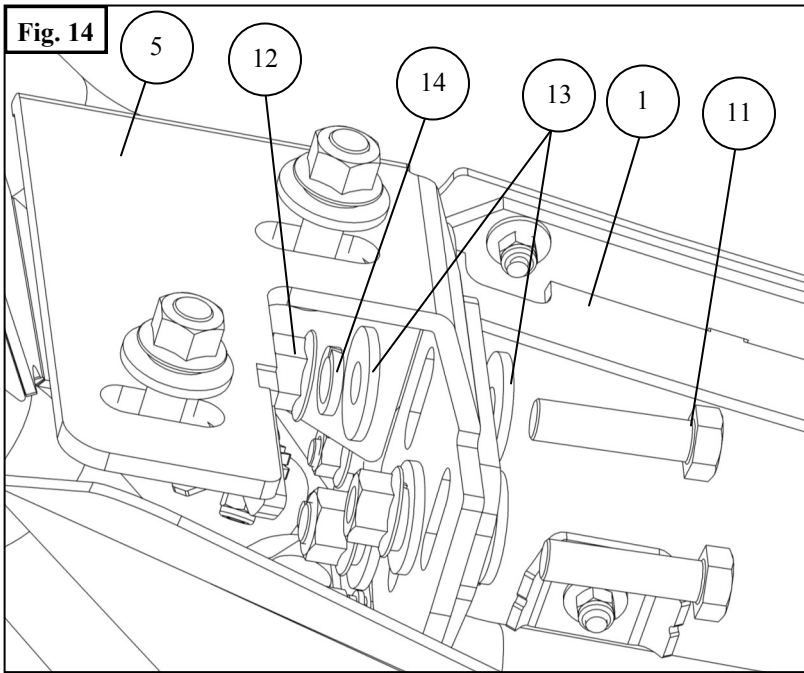


Rear view of driver's side.

Item 18



12. Using M8 serrated flange hex nuts (18), fasten corner cover into position. The serration on the nut should lock the nut in position allowing the installer to tighten button head bolts from the front using a 5mm Allen wrench. See **Figure 13**.
13. Using supplied M12 hardware (13-16), mount bumper to frame brackets according to **Figures 14-16, 20**.
14. Torque all M12 hardware to 50-55 ft-lbs.



15. Install M8 U-clips (10) the tabs on lower tube of bumper according to **Figure 17**.

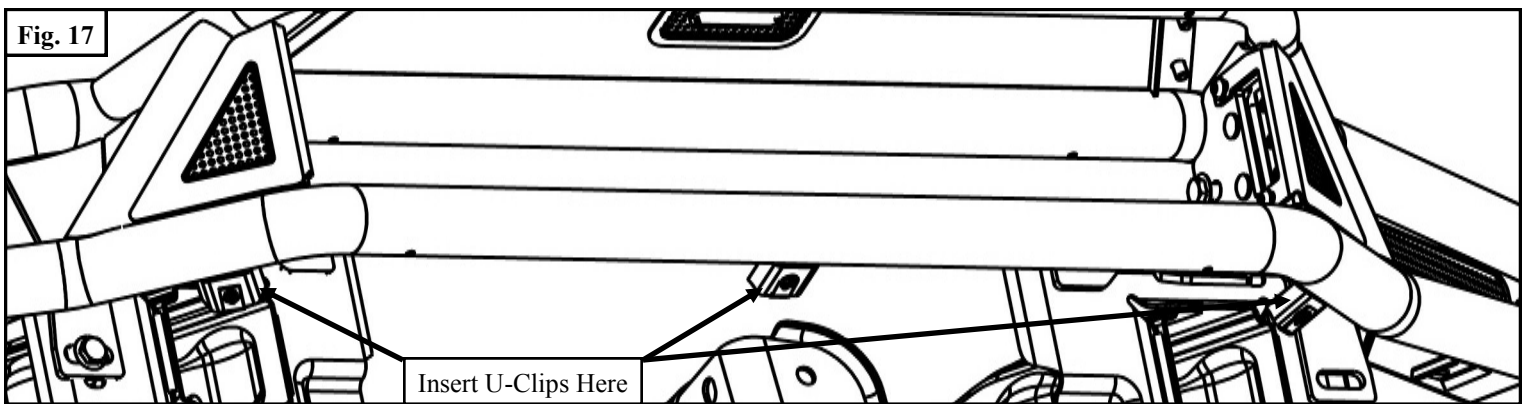
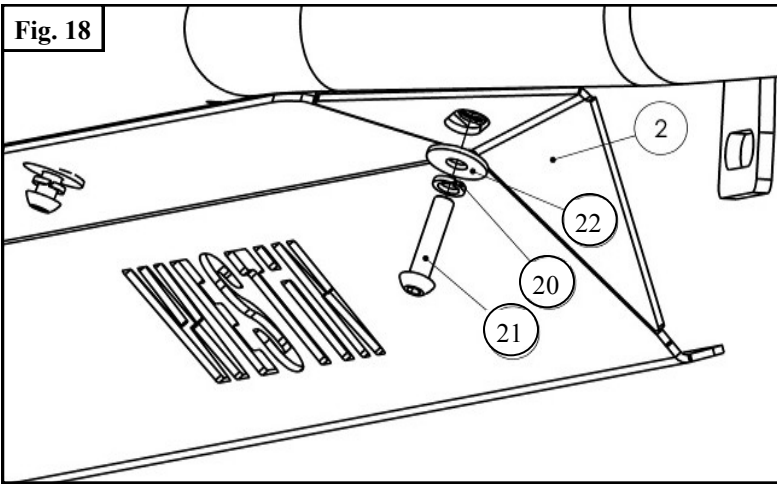


Fig. 18



16. Install upper skid plate (2) using items 20-22. See **Figures 18 and 19**.

17. Tighten M8 hardware to 15-18 ft-lbs.

Fig. 19

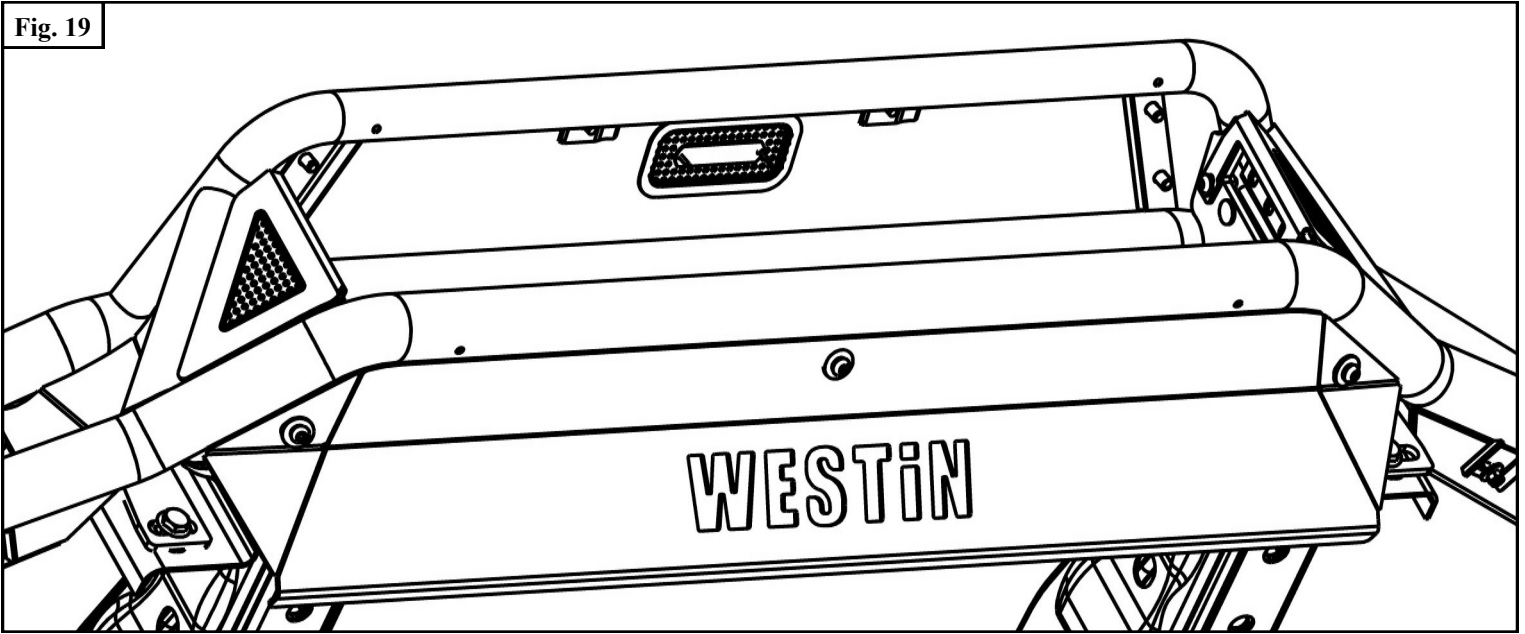
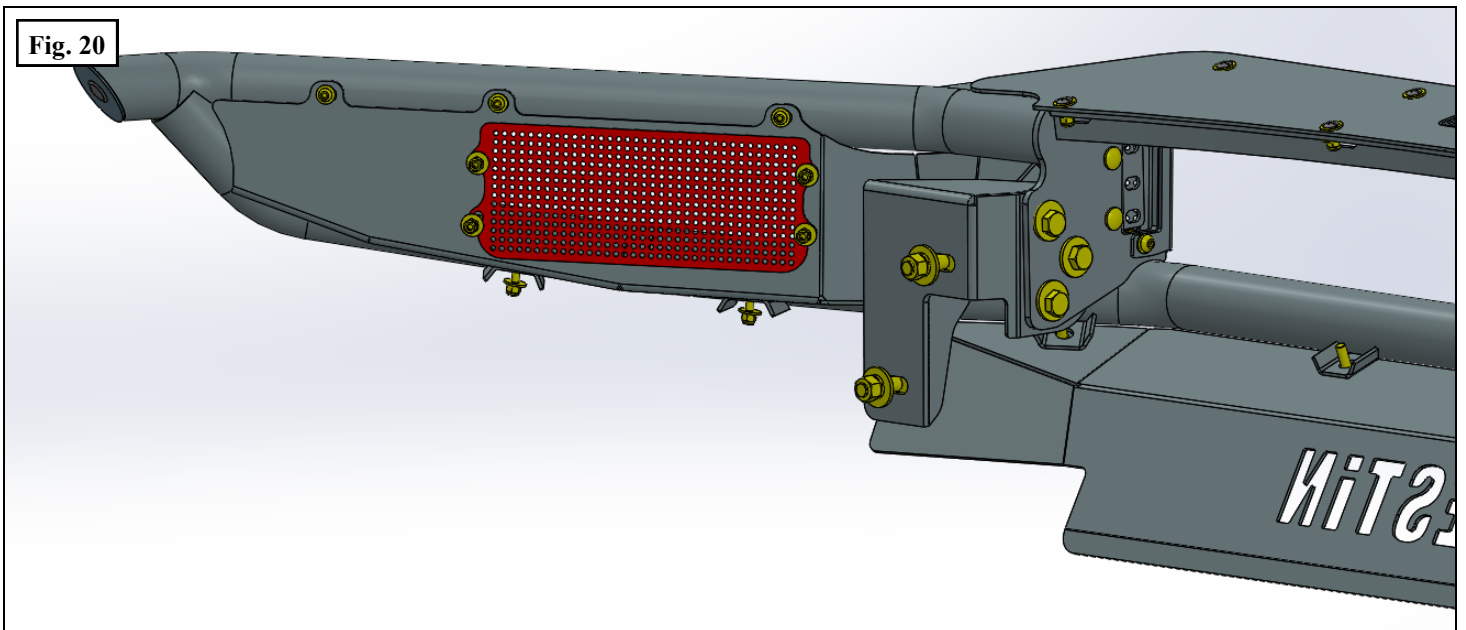


Fig. 20





# Installation Complete



## CARE INSTRUCTIONS

- REGULAR WAXING IS RECOMMENDED. DO NOT USE ANY TYPE OF POLISH OR WAX THAT MAY CONTAIN ABRASIVES.
- STAINLESS STEEL PRODUCTS CAN BE CLEANED WITH MILD SOAP AND WATER. STAINLESS STEEL POLISH SHOULD BE USED TO POLISH SMALL SCRATCHES.
- GLOSS BLACK FINISHES SHOULD BE CLEANED WITH MILD SOAP AND WATER.

**WESTIN**



## WARNING



Failure to follow these instructions could lead to death, personal injury, and / or property damage.

Failure to follow these instructions could lead to death, personal injury, and / or property damage.

### FASTENERS:

All Westin supplied fasteners must be utilized and installed in accordance with the installation instructions and apply torque to the specifications as defined. **DOUBLE CHECK ALL FASTENERS BEFORE INITIAL USE, AND PERIODICALLY IN THE FUTURE TO ENSURE PROPER FUNCTION AND SAFETY.**

### DRILLING:

Most Westin products do not require drilling for installation. If drilling is defined as required, use caution when drilling a vehicle. **FAILURE TO REVIEW AN AREA TO BE DRILLED MAY RESULT IN PERSONAL INJURY AND/OR INJURY TO OTHERS AS WELL AS VEHICLE DAMAGE.**

### EYE PROTECTION:

**ALWAYS WEAR SAFETY GLASSES OR GOGGLES DURING THE INSTALLATION PROCESS TO AVOID PERSONAL INJURY.**

### MAXIMUM TOWING/CARRYING CAPACITY: (if applicable)

The Westin Receiver Hitches will have a visible tow rating label affixed directly on the product. User should never exceed the vehicle manufacturers maximum tow and weight rating regardless of the capacity of the hitch. **FAILURE TO FOLLOW THESE GUIDELINES WILL VOID THE WESTIN WARRANTY AND MAY RESULT IN PERSONAL INJURY AND/OR INJURY TO OTHERS AS WELL AS VEHICLE DAMAGE.**

### FOR CALIFORNIA RESIDENTS ONLY-PROP 65 WARNING:

Some products may contain chemicals such as DEHP, which can cause cancer, birth defects or other reproductive harm.



Learn more about off-road bumpers we have.