

INSTALLATION INSTRUCTIONS

OUTLAW FRONT BUMPER



APPLICATION:
2019-2020 Chevrolet Silverado 1500 (Excl. LD)
PART NUMBER:
58-61215

CONTENT			
ITEM	QUANTITY	DESCRIPTION	TOOLS NEEDED
1	1	OUTLAW FRONT BUMPER	13MM SOCKET
2	1	UPPER SKID PLATE	ALLEN WRENCH
3	1	DRIVER MESHED CORNER COVER	15MM SOCKET
4	1	PASSENGER MESHED CORNER COVER	19MM SOCKET
5	2	MESHED LED SIDE COVER	19MM WRENCH
6	1	DRIVER FRAME BRACKET	RATCHET
7	1	PASSENGER FRAME BRACKET	TORQUE WRENCH
8	1	DRIVER LED SLIDER BRACKET	
9	1	PASSENGER LED SLIDER BRACKET	
10	1	DRIVER LED L-BRACKET	
11	1	PASSENGER LED L-BRACKET	
12	1	DRIVER CENTER SENSOR TAB	
13	1	PASSENGER CENTER SENSOR TAB	
14	2	SIDE SENSOR TAB	
15	4	SENSOR HOLE PLUGS	
16	1	DRIVER TEMPLATE	
17	1	PASSENGER TEMPLATE	
18	6	M12 HEX HEAD BOLT	
19	12	M12 FLAT WASHER	
20	6	M12 SPLIT LOCK WASHER	
21	6	M12 HEX NUTS	
22	8	M8 CARRIAGE BOLTS	
23	8	M8 HEX NUTS	
24	12	SMALL M8 FLAT WASHERS	
25	17	M8 SPLIT LOCK WASHERS	
26	2	M10 HEX NUTS	
27	4	M8 SERRATED FLANGE NUTS	
28	2	M6 HEX HEAD BOLT	

ANTI-SEIZE LUBRICANT MUST BE USED ON ALL STAINLESS STEEL FASTENERS TO PREVENT THREAD DAMAGE AND GALLING



29	2	M10 LOCK WASHERS	
30	5	LARGE M8 FLAT WASHERS	
31	2	M10 HEX DRIVE BUTTON HEAD BOLT	
32	4	M10 FLAT WASHERS	
33	9	M8 HEX DRIVE BUTTON HEAD BOLT	
34	5	M8 U CLIPS	
35	2	M6 CARRIAGE BOLT	
36	2	M6 HEX NUT	
37	4	M6 SPLIT LOCK WASHER	
38	4	M6 FLAT WASHER	
39	10	ZIP TIES	
40	5	DOUBLE SIDED TAPE SQUARE	
41	1	DRIVER SKID PLATE SUPPORT BRACKET	
42	1	PASSENGER SKID PLATE SUPPORT BRACKET	

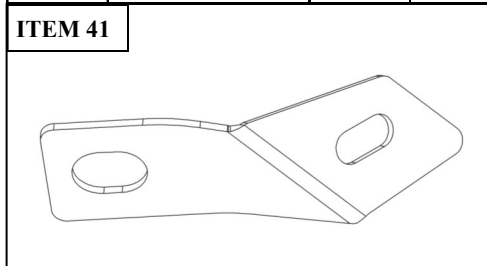
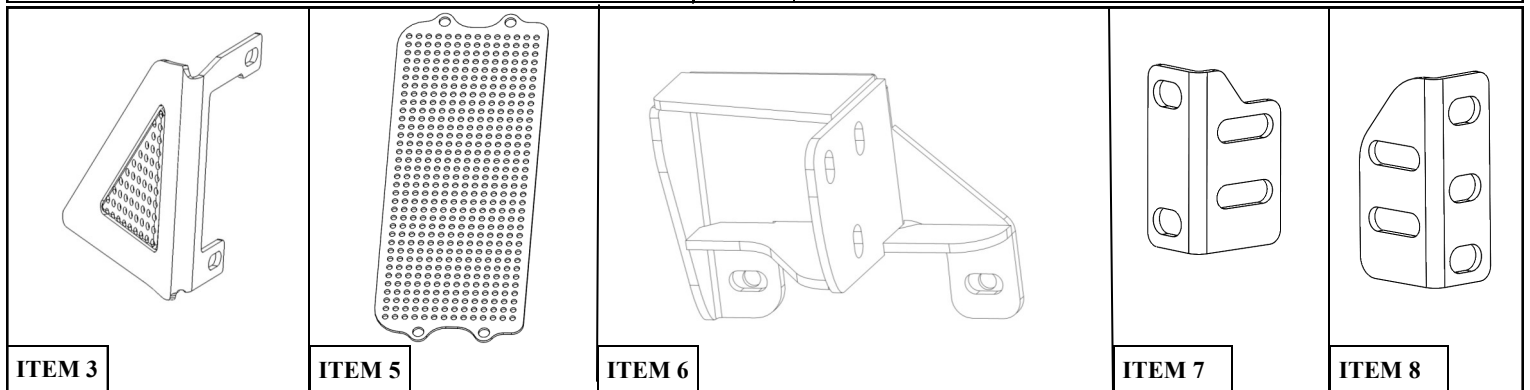
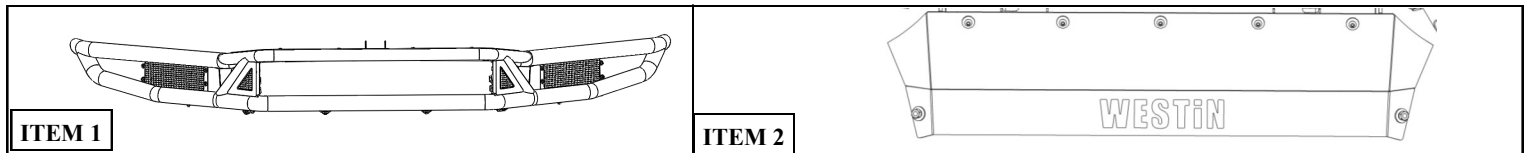

PROCEDURE

1. Remove contents from box, verify if all parts listed are present and free from damage.
Carefully read and understand all instructions before attempting installation.
Failure to identify damage before installation could lead to a rejection of any claim.

2. Begin by removing the plastic trim fasteners holding the grille in place. Also detatch the clips of the wings of the grille. See **Figures 1 & 2**.
3. Remove the grille by pulling firmly and carefully at the bottom of the grille.

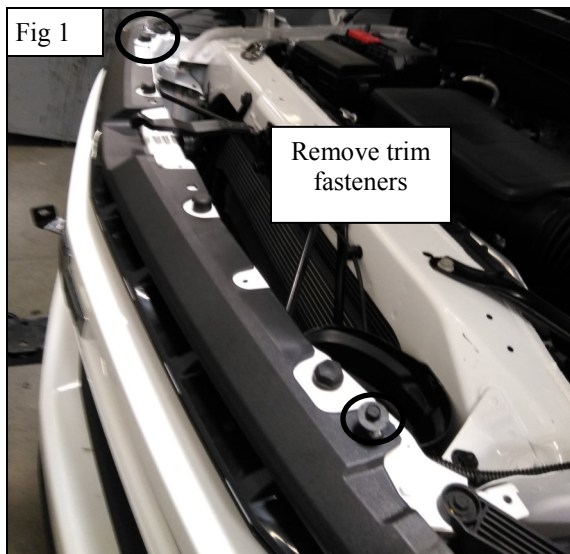

4. Remove the 4 bolts behind the plastic cover securing the bumper to the vehicle. See **Figure 3**.
5. Remove the bolts on the bottom of the frame securing the bumper supports to the vehicle. See **Figure 4**.
6. Unplug any wire connections and remove the bumper.

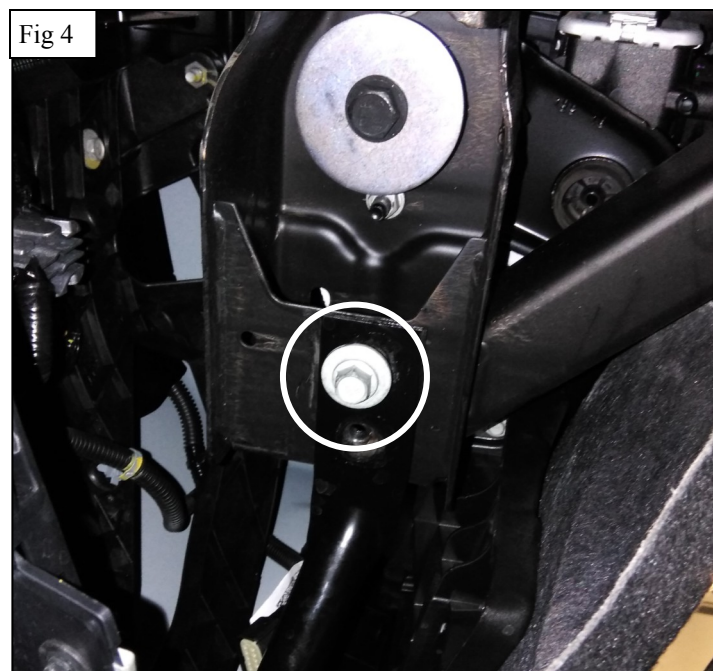

7. Unbolt the tow hooks (if equipped). They will be re-installed later.
8. The front corner pieces will need to be removed for trimming. Remove the hardware holding on the two brackets circled in **Figure 5**.
9. Remove the screws on the inner fender lining holding on the corner piece.
10. Pull off corner piece assembly.
11. Repeat on the opposite side.



TRIMMING NEEDED

- Trimming of the factory Front Corner Pieces will be necessary to install the Pro Mod Front Bumper.
- If you would not like to trim the stock Corner Pieces, OE replacement pieces to trim instead (PN Right-84658018, PN Left-84658017) may be purchased separately and installed. **ONLY ONE OPTION IS NEEDED: YOU MAY EITHER TRIM THE OEM PIECE OR PURCHASE A REPLACEMENT TO TRIM INSTEAD.**

TRIMMING PROCEDURE

- With the bumper now off, you will take the supplied templates and align them on the front corner pieces. Tape at the specified areas on the template. See **Figure 6**
- Make sure that the template is aligned with the curve and is level across the bottom to ensure a straight cut.
- Using a cutting tool, trim the corner piece below the line as specified on the template. See **Figure 7**
- Repeat the process on the opposite side.
- Reinstall the corner pieces.

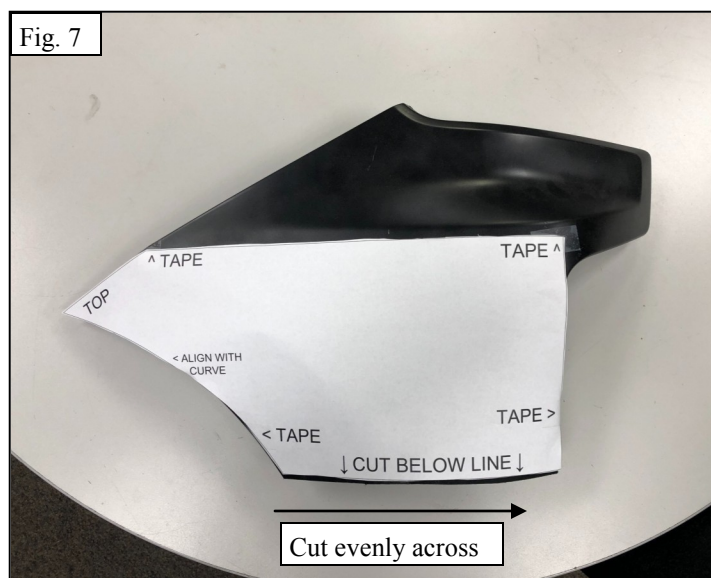
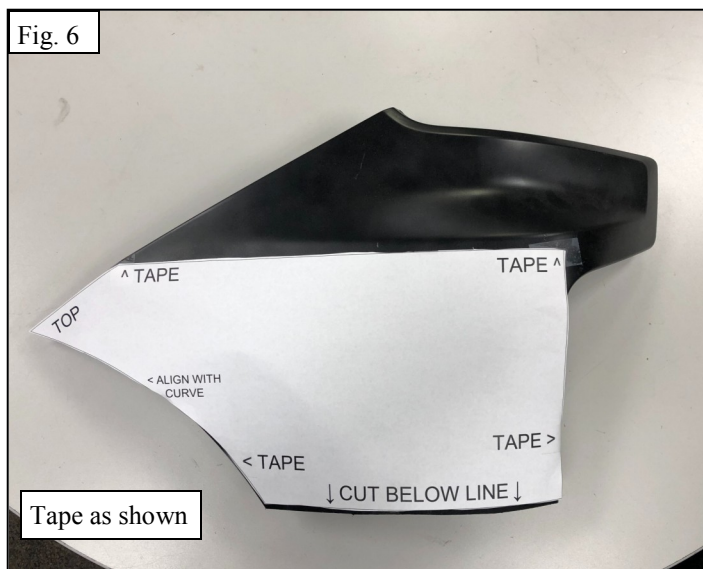

12. Locate the frame mounting brackets and skid plate support bracket. Reusing the factory bumper bolts, mount the bumper/skid plate brackets to the frame. See **Figure 8**.

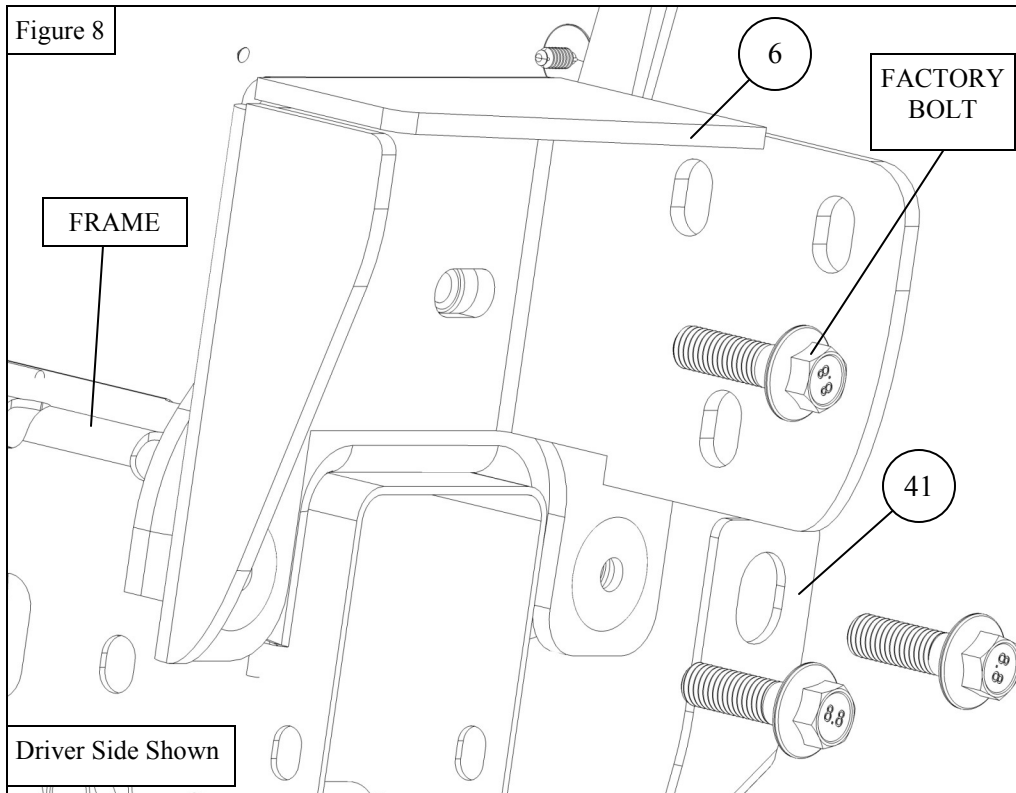

13. Proceed to install center light bar brackets (and light bar (s)) on the bumper. The LED brackets can be mounted in different configurations in order to have the necessary adjustment for various “30” inch light bar overall lengths. See **Figure 9-11**.

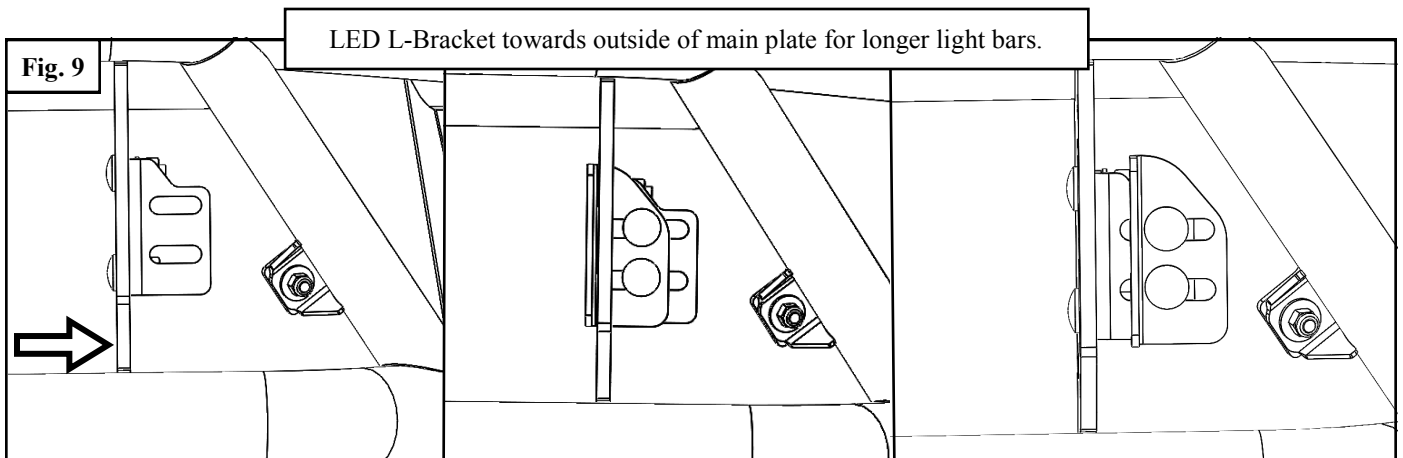

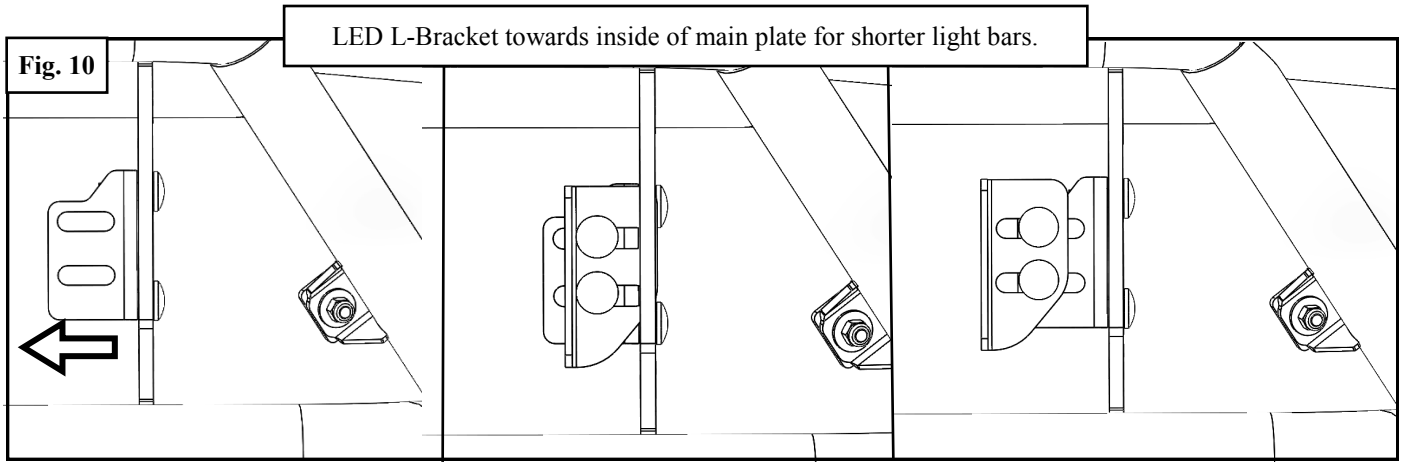
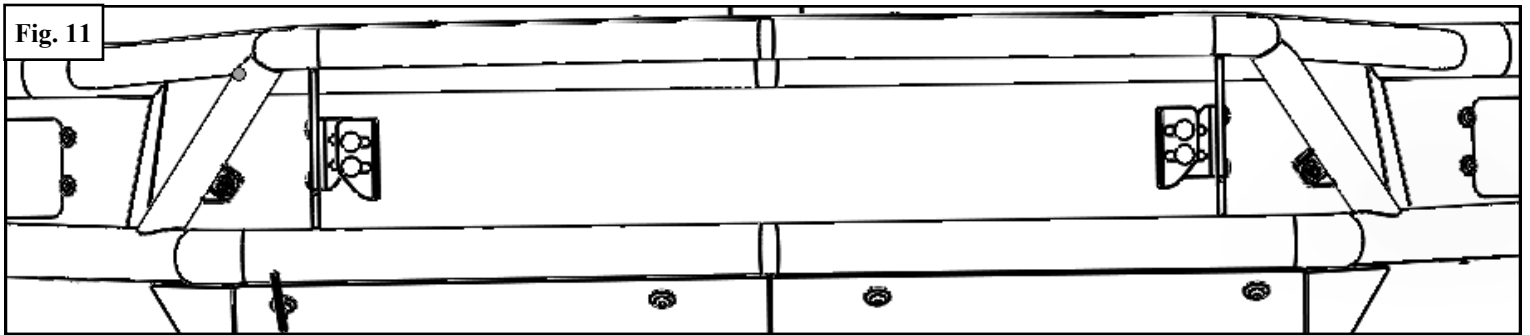
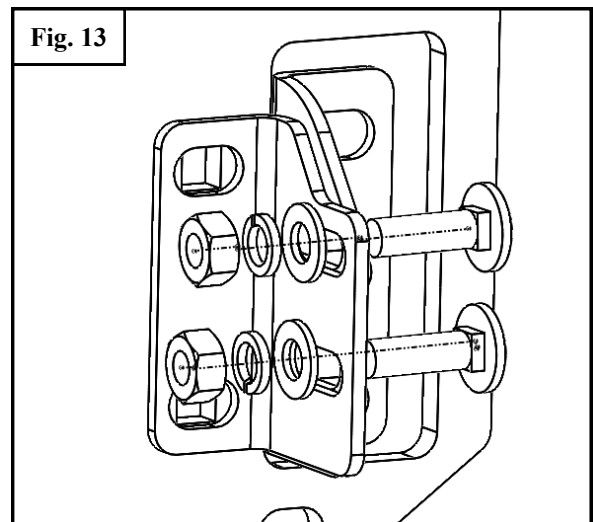
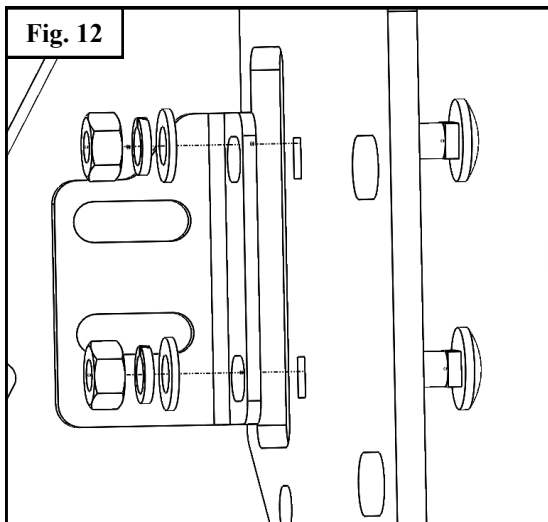
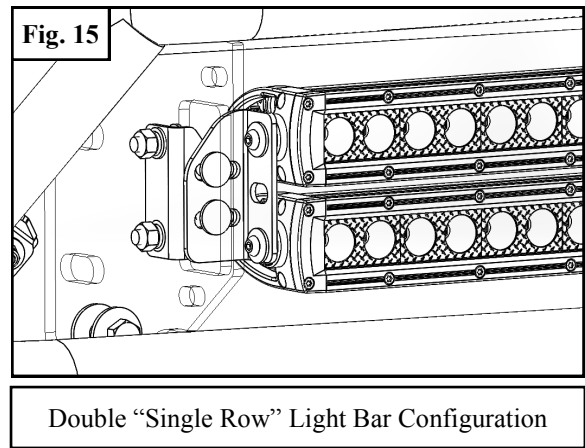
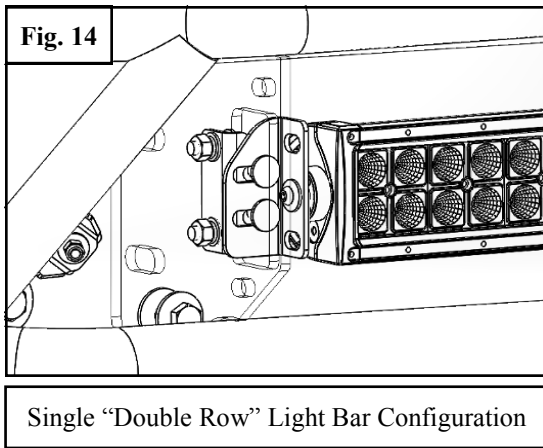

Figure 11 is an example that shows the LED brackets towards the inside adjusted in for the shortest light bar configuration.



14. Using items 24, 22, 23, and 25 fasten LED L-Brackets to main plate. Do not tighten. See **Figure 12**.
15. Using items 24, 22, 23, and 25 fasten LED Slider Bracket to LED L-Bracket. Do not tighten. See **Figure 13**.
16. Using hardware included in the LED light bar hardware kit, fasten to bracket according to **Figures 14 & 15**.
17. Position light bar as desired and tighten all M8 hardware to 15-18 ft-lbs.





18. Position the meshed corner covers as seen in **Figures 16 & 17.**

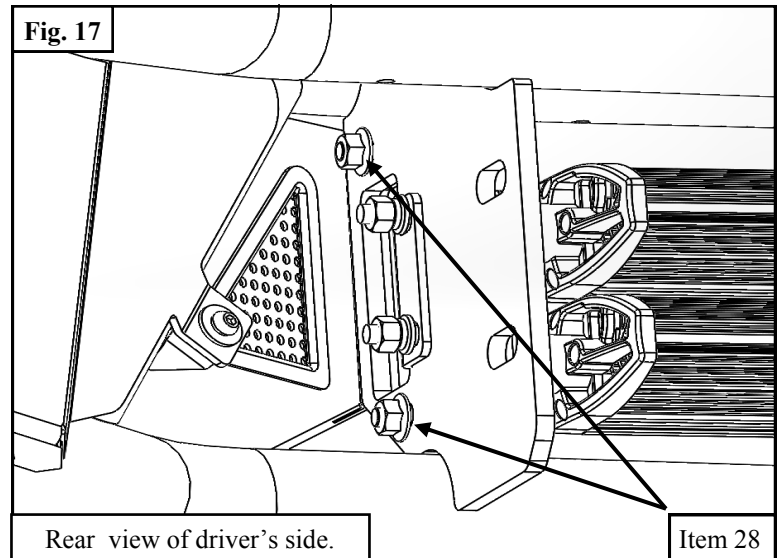
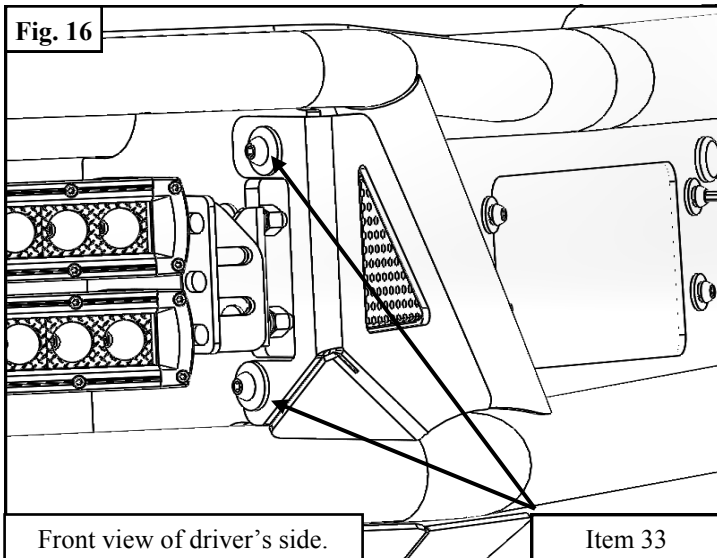

19. Using M8 serrated flange hex nuts, fasten corner covers into position. The serration on the nut should lock the nut in position allowing the installer to tighten button head bolts from the front using a 5mm Allen wrench. See **Figure .**
20. Using supplied M12 hardware , mount bumper to frame brackets according to **Figures 18-20.**
21. Torque all M12 hardware to 50-55 ft-lbs.

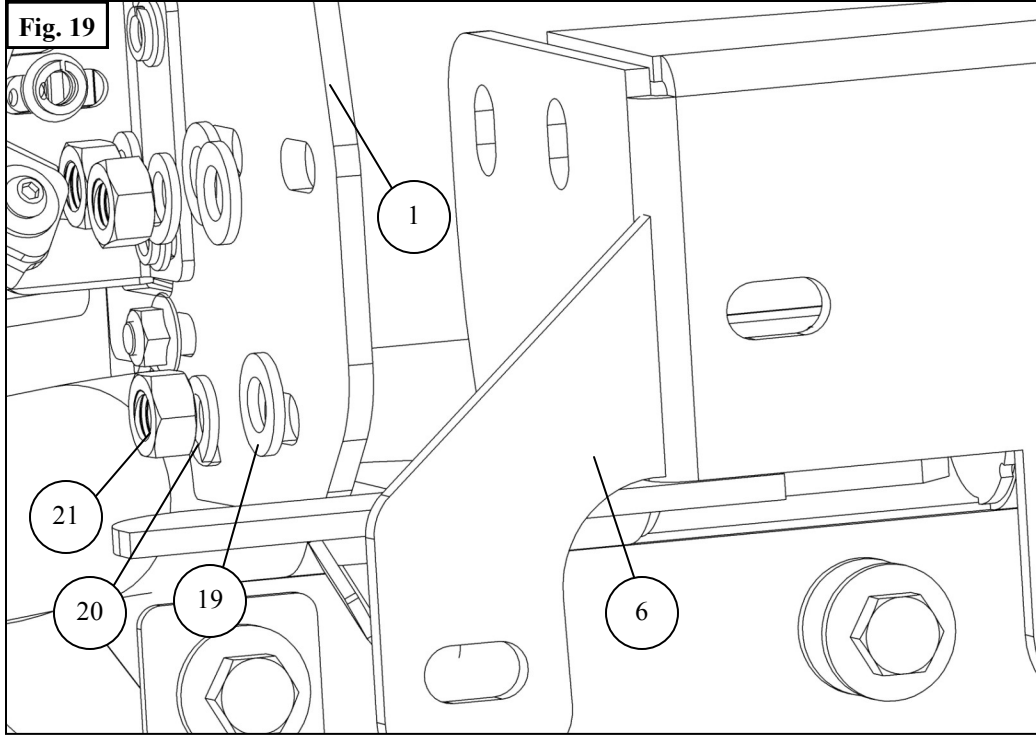
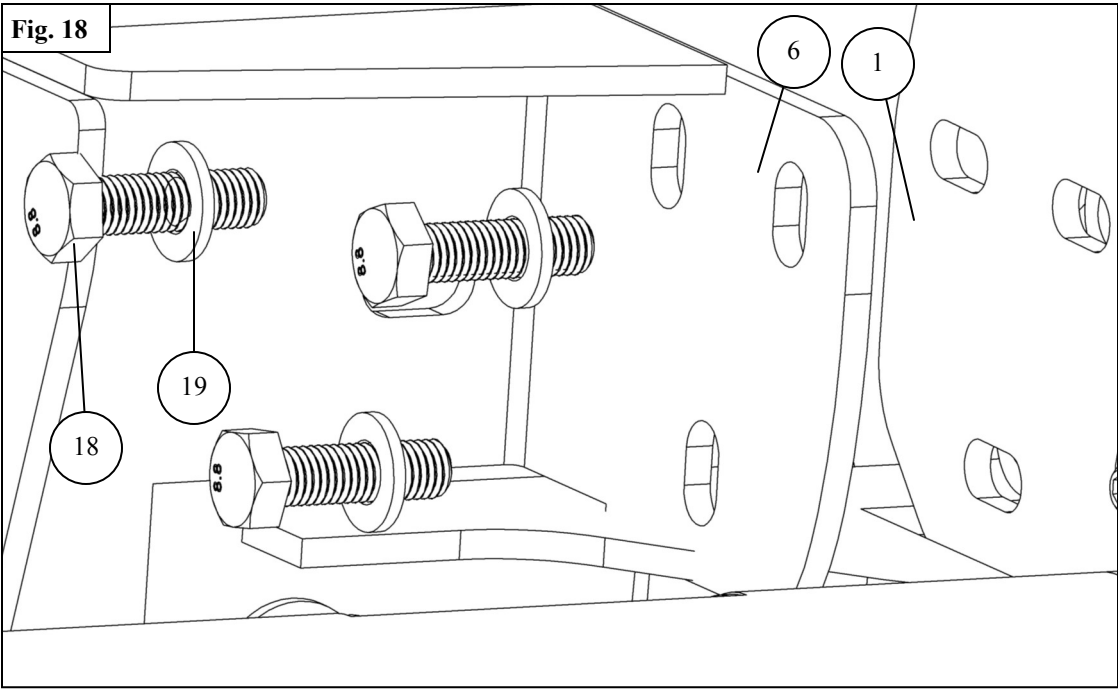
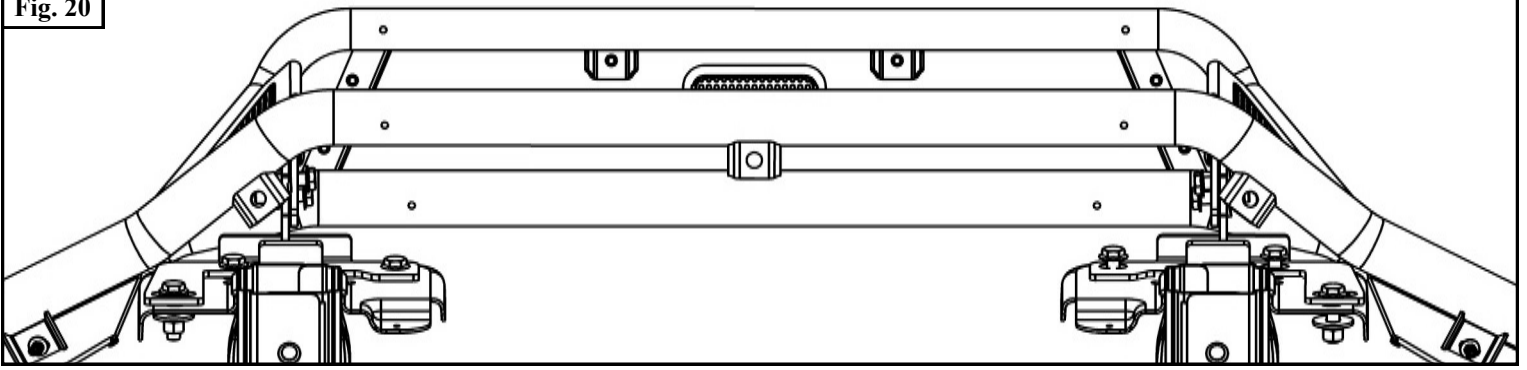

Fig. 20



22. Install M8 U-clips the tabs on lower tube of bumper according to **Figure 21**.

Fig. 21

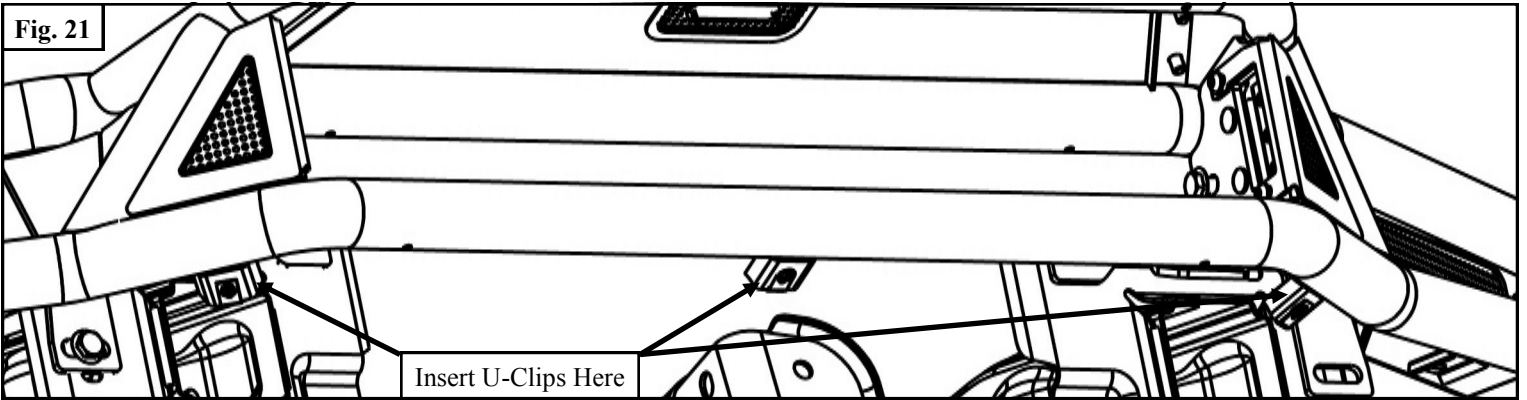
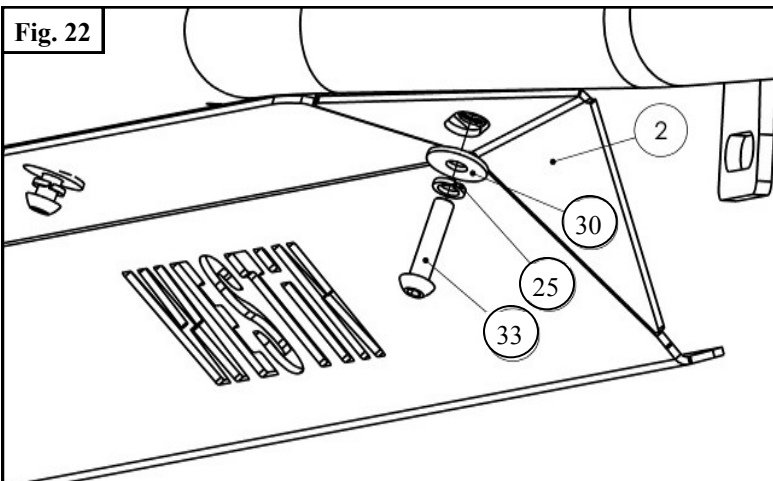

Fig. 22



23. Install upper skid plate using items 30, 25, and 33 .
See **Figures 22 and 23**.
24. Tighten M8 hardware to 15-18 ft-lbs.

Fig. 23

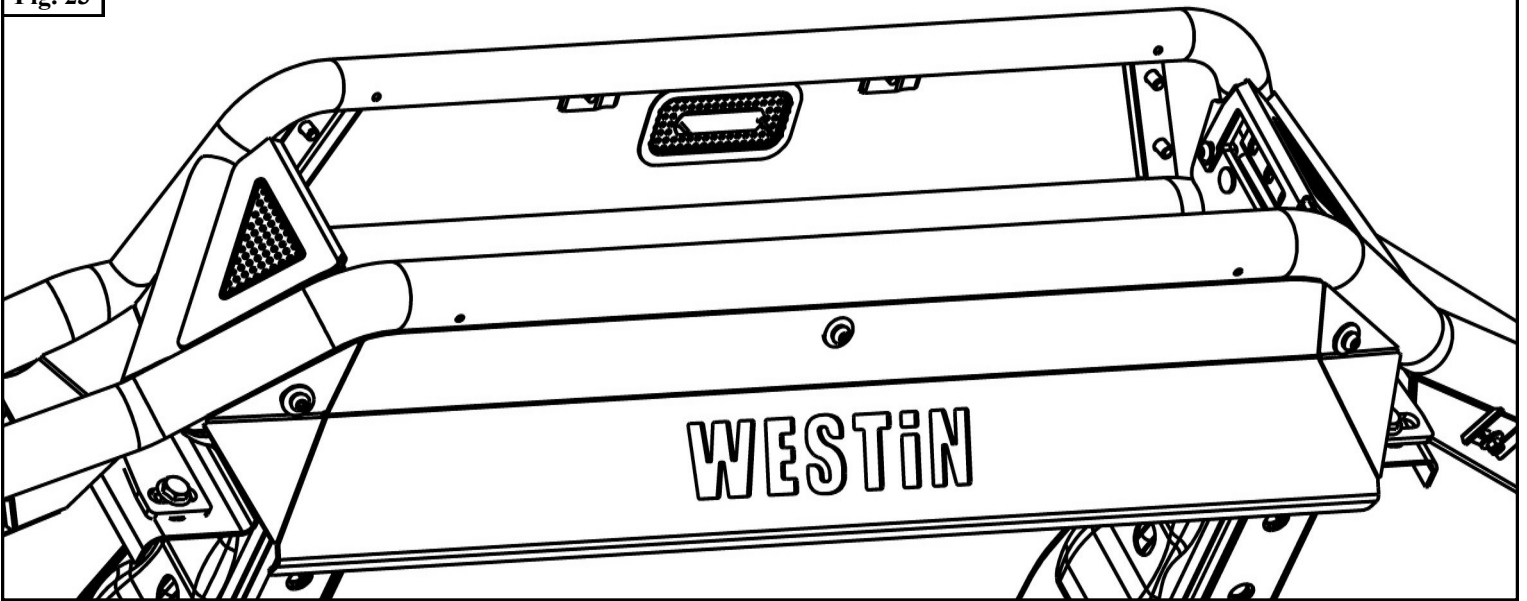
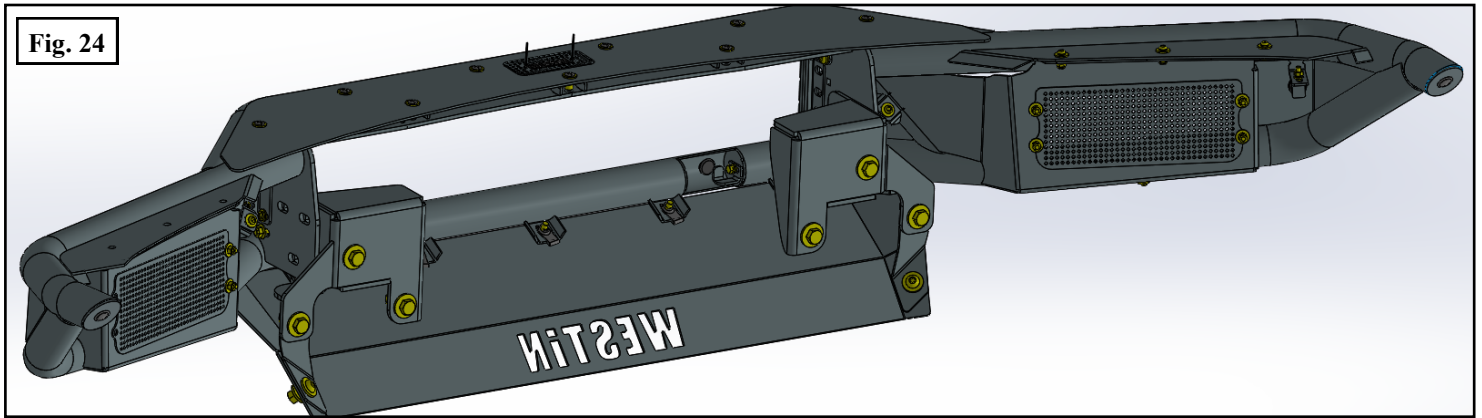

Fig. 24



CARE INSTRUCTIONS

- REGULAR WAXING IS RECOMMENDED. DO NOT USE ANY TYPE OF POLISH OR WAX THAT MAY CONTAIN ABRASIVES.
- STAINLESS STEEL PRODUCTS CAN BE CLEANED WITH MILD SOAP AND WATER. STAINLESS STEEL POLISH SHOULD BE USED TO POLISH SMALL SCRATCHES.
- GLOSS BLACK FINISHES SHOULD BE CLEANED WITH MILD SOAP AND WATER.

INSTALLATION COMPLETED



WESTiN



WARNING



Failure to follow these instructions could lead to death, personal injury, and / or property damage.

Failure to follow these instructions could lead to death, personal injury, and / or property damage.

FASTENERS:

All Westin supplied fasteners must be utilized and installed in accordance with the installation instructions and apply torque to the specifications as defined. **DOUBLE CHECK ALL FASTENERS BEFORE INITIAL USE, AND PERIODICALLY IN THE FUTURE TO ENSURE PROPER FUNCTION AND SAFETY.**

DRILLING:

Most Westin products do not require drilling for installation. If drilling is defined as required, use caution when drilling a vehicle. **FAILURE TO REVIEW AN AREA TO BE DRILLED MAY RESULT IN PERSONAL INJURY AND/OR INJURY TO OTHERS AS WELL AS VEHICLE DAMAGE.**

EYE PROTECTION:

ALWAYS WEAR SAFETY GLASSES OR GOGGLES DURING THE INSTALLATION PROCESS TO AVOID PERSONAL INJURY.

MAXIMUM TOWING/CARRYING CAPACITY: (if applicable)

The Westin Receiver Hitches will have a visible tow rating label affixed directly on the product. User should never exceed the vehicle manufacturers maximum tow and weight rating regardless of the capacity of the hitch. **FAILURE TO FOLLOW THESE GUIDELINES WILL VOID THE WESTIN WARRANTY AND MAY RESULT IN PERSONAL INJURY AND/OR INJURY TO OTHERS AS WELL AS VEHICLE DAMAGE.**

FOR CALIFORNIA RESIDENTS ONLY-PROP 65 WARNING:

Some products may contain chemicals such as DEHP, which can cause cancer, birth defects or other reproductive harm.



Learn more about off-road bumpers we have.