

INSTALLATION INSTRUCTIONS

OUTLAW FRONT BUMPER

WESTiN®

APPLICATION:
2016-2018 Toyota Tacoma
PART NUMBER:
58-61045

CONTENT			
ITEM	QUANTITY	DESCRIPTION	TOOLS NEEDED
1	1	OUTLAW FRONT BUMPER	14MM SOCKET
2,3	2	FRAME BRACKET, DRIVER (2) AND PASSENGER (3)	RATCHET
4,5	2	SUPPORT STRAP, DRIVER (4) AND PASSENGER (5)	TORQUE WRENCH
6,7	2	LED SLIDER BRACKET, DRIVER (6) AND PASSENGER (7)	17MM SOCKET
8,9	2	LED L-BRACKET, DRIVER (8) AND PASSENGER (9)	13MM SOCKET
10,11	2	MESHED CORNER COVER, DRIVER (10) AND PASSENGER (11)	19MM SOCKET
12	2	MESHED SIDE LED COVER	19MM WRENCH
13	2	SPACER BRACKET	14MM WRENCH
14	4	M10 HEX HEAD BOLT (BLACK ZINC)	13MM WRENCH
15	8	M10 FLAT WASHER (BLACK ZINC)	17MM WRENCH
16	4	M10 SPLIT LOCK WASHER (BLACK ZINC)	5MM ALLEN
17	4	M10 HEX NUT (BLACK ZINC)	PRY TOOL
18	6	M12 SERRATED FLANGE HEX HEAD BOLT (BLACK ZINC)	MASKING TAPE
19	12	M12 FLAT WASHER (BLACK ZINC)	TRIMMING TOOL
20	6	M12 SPLIT LOCK WASHER (BLACK ZINC)	MARKER
21	6	M12 HEX NUT (BLACK ZINC)	RULER
22	8	M8 CARRIAGE BOLT (BLACK ZINC)	LEVEL
23	8	M8 HEX NUT (BLACK ZINC)	PHILLIPS SCREW-DRIVER
24	12	M8SPLIT LOCK WASHER (BLACK ZINC)	10MM SOCKET
25	12	M8 FLAT WASHER (BLACK ZINC)	
26	4	M8 BUTTON HEAD BOLT (BLACK ZINC)	
27	4	M8 SERRATED FLANGE NUT (BLACK ZINC)	

ANTI-SEIZE LUBRICANT MUST BE USED ON ALL STAINLESS STEEL FASTENERS TO PREVENT THREAD DAMAGE AND GALLING

CARE INSTRUCTIONS

- REGULAR WAXING IS RECOMMENDED. DO NOT USE ANY TYPE OF POLISH OR WAX THAT MAY CONTAIN ABRASIVES.
- STAINLESS STEEL PRODUCTS CAN BE CLEANED WITH MILD SOAP AND WATER. STAINLESS STEEL POLISH SHOULD BE USED TO POLISH SMALL SCRATCHES.
- GLOSS BLACK FINISHES SHOULD BE CLEANED WITH MILD SOAP AND WATER.

WESTiN

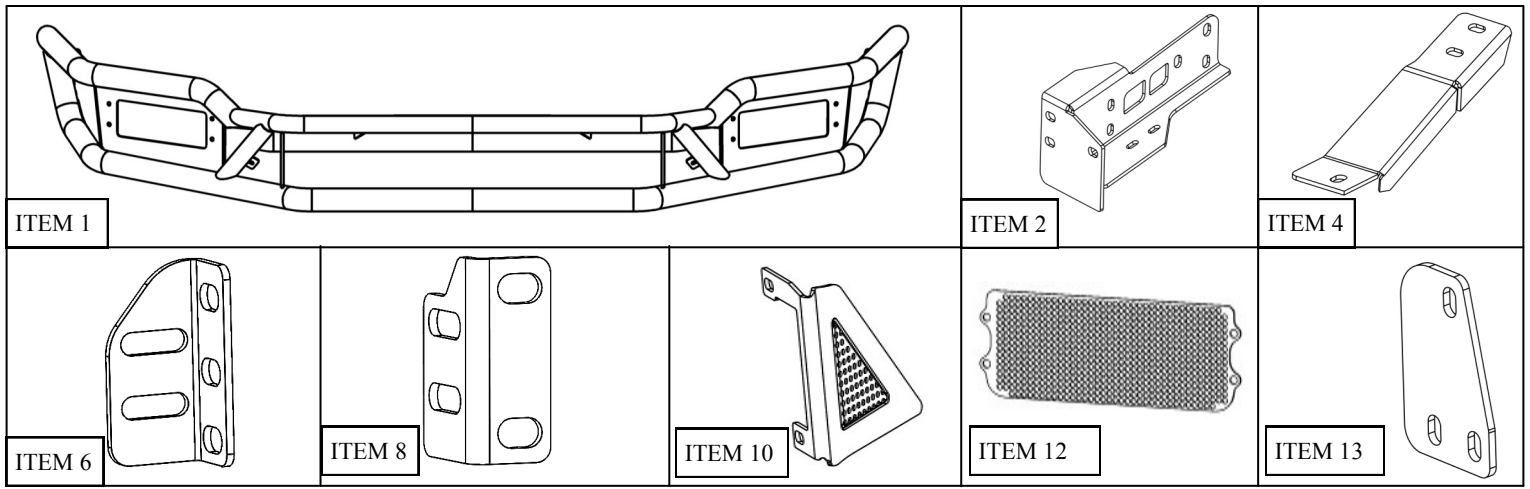

PROCEDURE

1. Remove contents from box, verify if all parts listed are present and free from damage. Carefully read and understand all instructions before attempting installation.

Failure to identify damage before installation could lead to a rejection of any claim.

2. To remove front bumper, first remove the grill, fender flares and valance.

To remove grill, remove two screws and push pins fastening it to the radiator area. See **Figure 1 and 2**. Once all fasteners have been removed, firmly pull radiator from top towards the front of the vehicle.

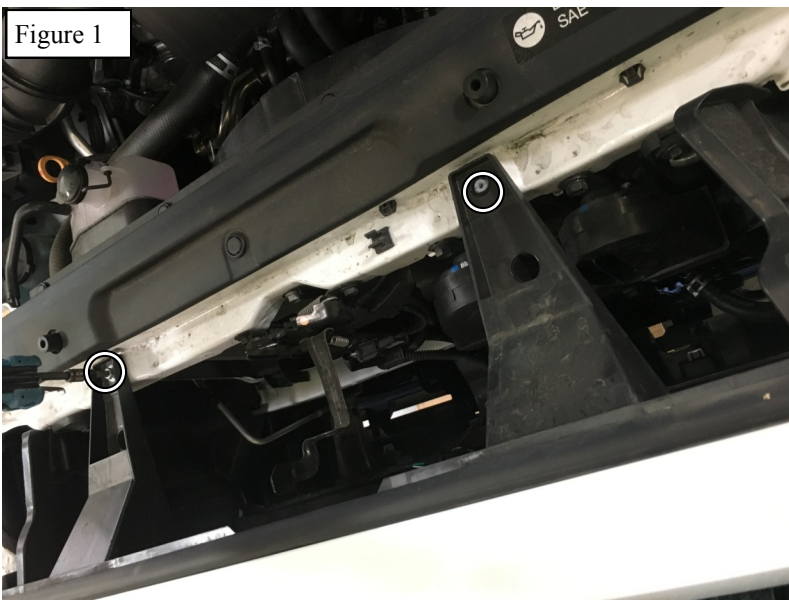

3. Next, remove fender flares by removing screws around the wheel well area; once all visible fasteners have been removed, firmly and carefully pull to unclip push pins. Save fender flares for later. They will be installed back and trimmed. See Figure 3

Figure 3



Figure 4

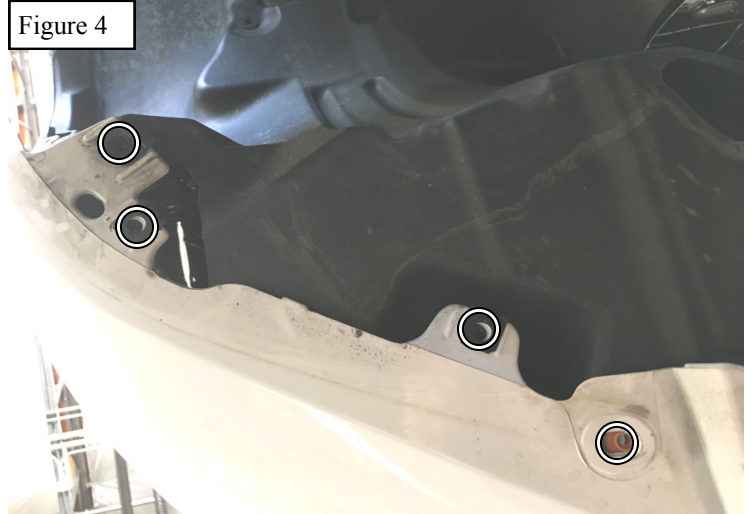

4. Remove valance by removing all fasteners holding it to the bottom of the bumper and wheel well liners. See Figures 4 and 5.

5. Remove all push pins fastening the bumper to the vehicle around the grille area and around head lights. Also, make sure to disconnect all wires and fog lights attached to the bumper.

Figure 5

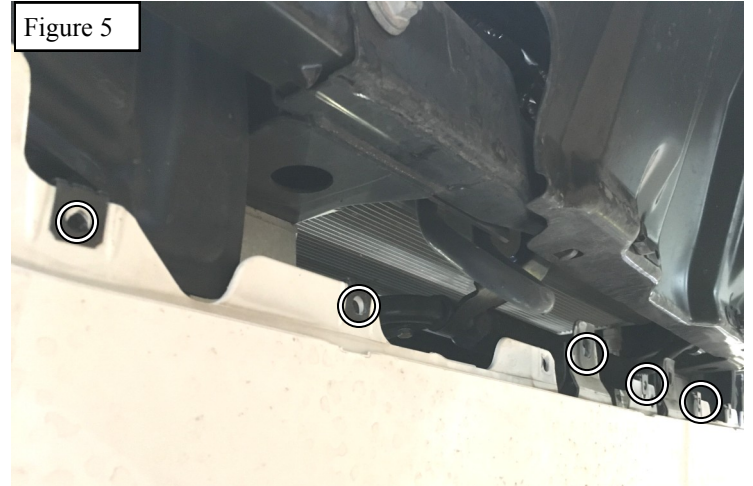
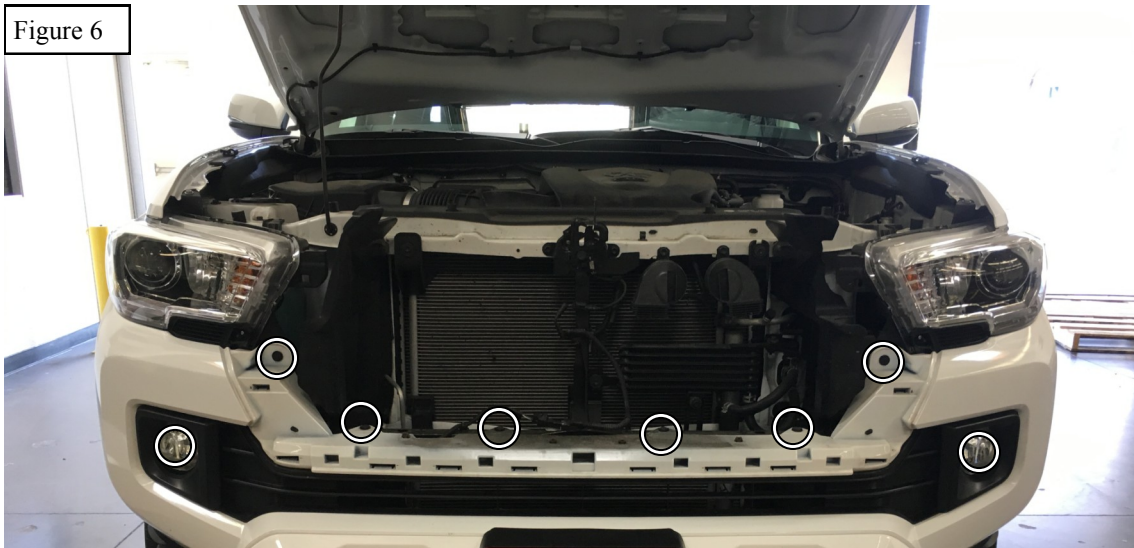

Figure 6



6. To remove bumper, it is recommended to seek assistance from a second person. Begin by pushing back wheel well plastic to expose a red push pin holding the bumper to a black plastic piece bolted to the metallic fender. See **Figure 7 and 8**.

Figure 7



Figure 8

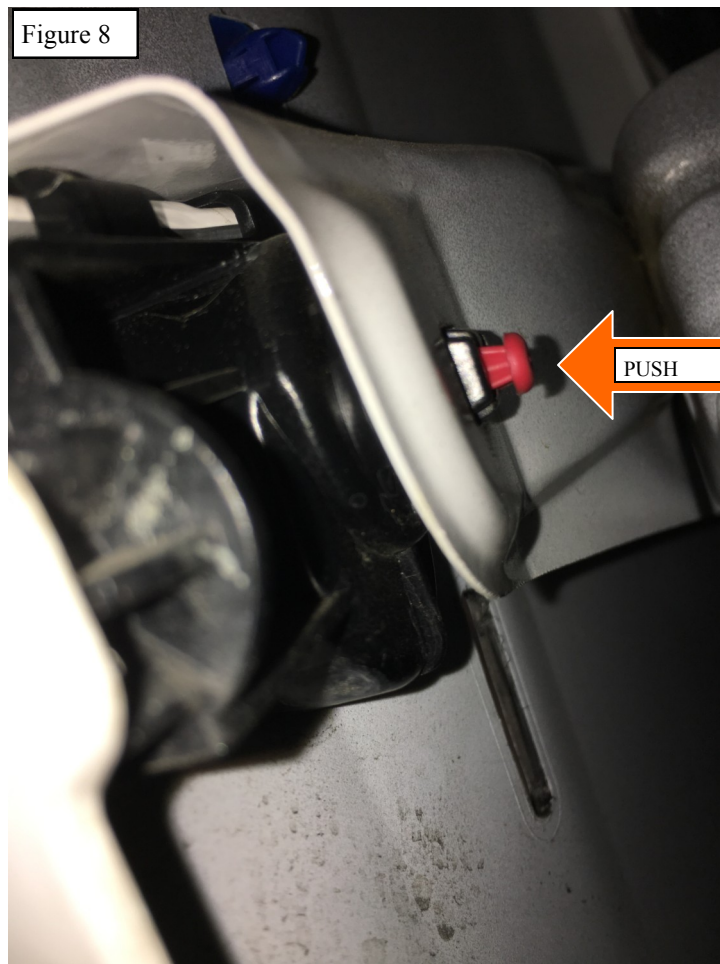

7. Push red pin to allow black plastic piece to be separated from metallic fender See **Figure 8**, then using a pry tool, insert under tab to separate from bumper. Carefully separate the three tabs on each side of the truck. See **Figure 9**. When you completely detach one side, have someone hold the bumper for you to avoid damage on the other side. It is not necessary to unbolt black plastic piece from the fender. The bumper will be installed back again later to prepare for trimming.

Figure 9



8. Next, remove the aluminum bar attached to the frame of the vehicle using a 14MM socket or wrench. Remove by pulling firmly both sides at the same time. Save these nuts, they will be re-used. See **Figure 10**.

9. Install item 13 to frame studs exposed on step 8. Do not thread nuts. Then, install main bracket item 2. Install OEM nuts removed on step 8 but do not tighten. See **Figures 11 and 12**.

Figure 10



Figure 11

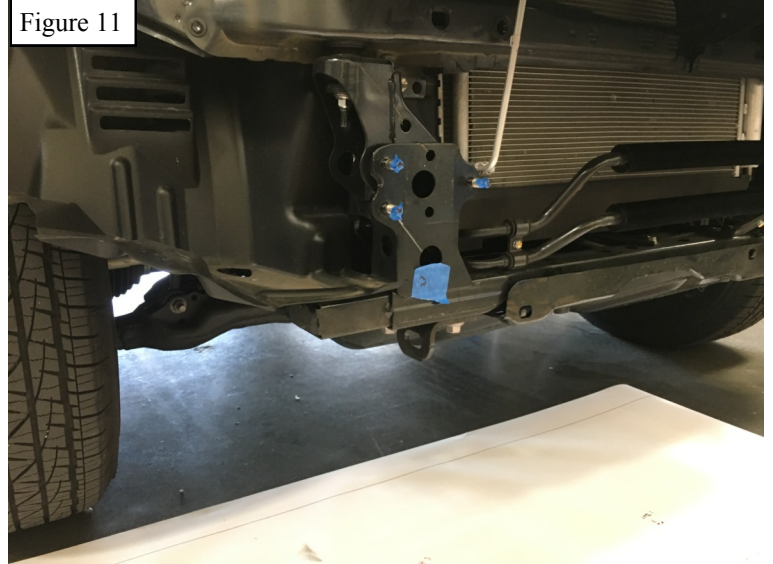

Figure 13

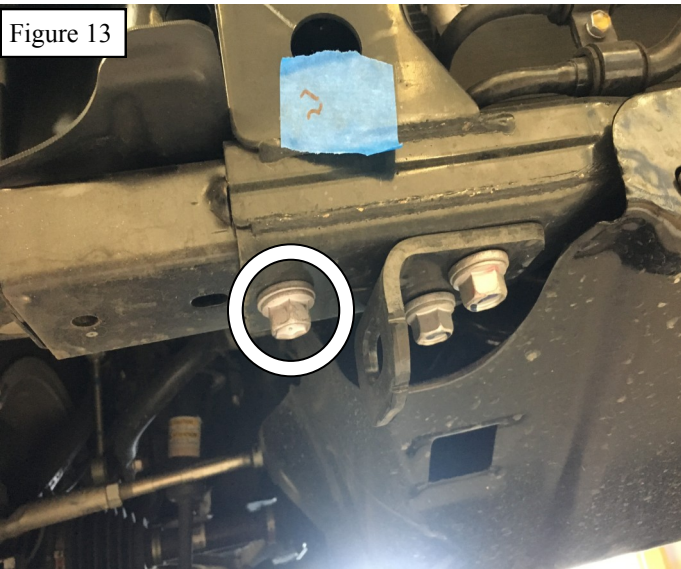
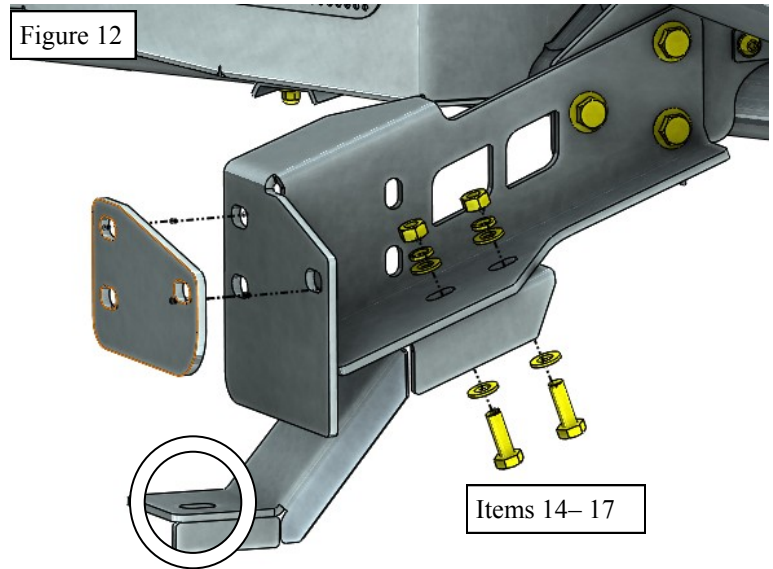

Figure 12



10. Item 4 (See **Figure 12**) bolt to stock bolt circled in **Figure 13**.

11. Proceed to install bumper according to **Figure 14**.

Use items 18-21 to fasten bumper to main bracket.

Position bumper straight and centered. When desired position is reached, tighten enough to prevent it from moving. No need to torque at this point. Then, using a ruler or measuring tape, measure the distance from the top of the upper tube to the ground. Make use is leveled. Record this distance. See **Figure 15**.

Then, remove Outlaw bumper and install OEM plastic bumper back on the truck .

Figure 14

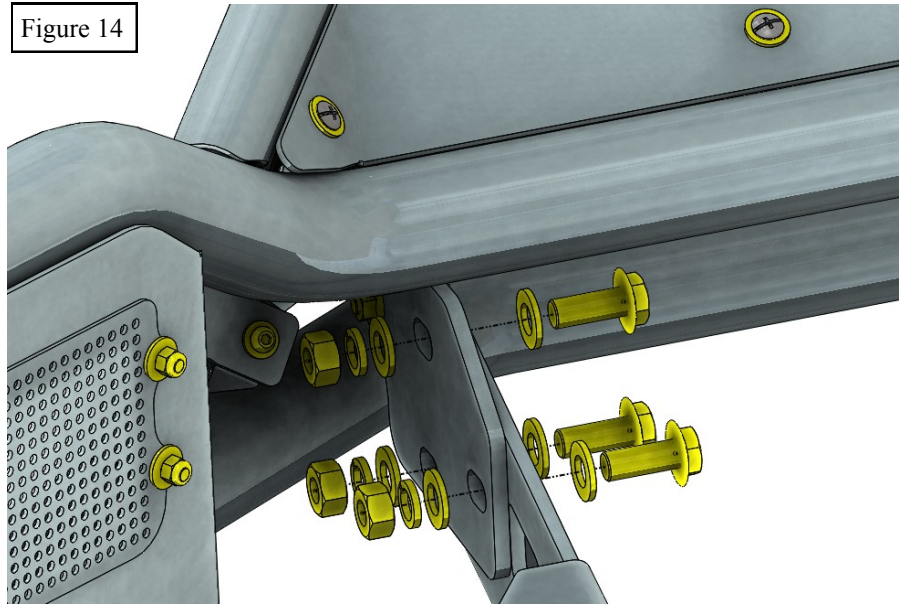
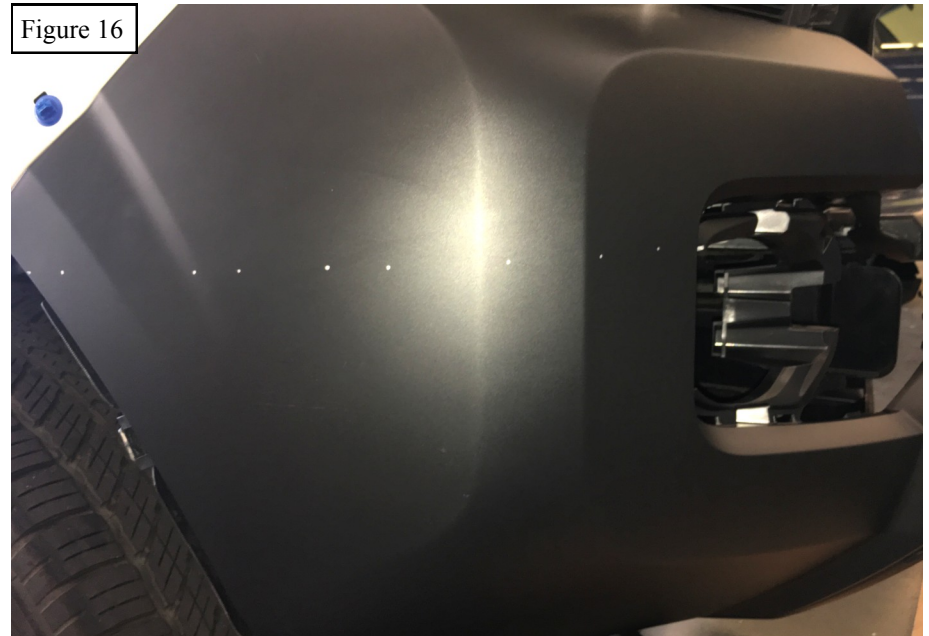

Figure 15



Figure 16



12. Measure the distance recorded on step 11 and mark OEM bumper and connect with masking tape. See **Figures 16-17**.

Remove bumper and vary carefully trim using a very sharp knife or cutting tool.

Leave some extra material, it can be tucked towards the back of the Outlaw bumper tube or trimmed again after. Use the same method to trim fender flares. These cuts should be straight cuts, only the area under the headlights from the fog light pockets to the wheel well will require trimming. (Top of tape on **figure 17**.)

Figure 17



13. Next, proceed to install center light bar brackets and light bar (s). The LED brackets (6-9) can be mounted in different configurations in order to have the necessary adjustment for various “30” inch light bar overall lengths. See **Figure 18-20**. *Note:* Lights sold separately.

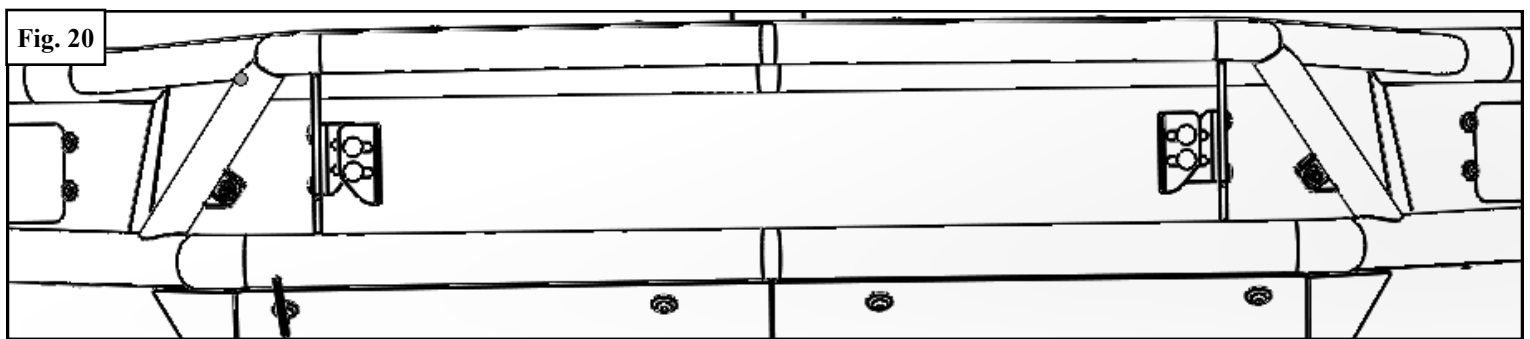
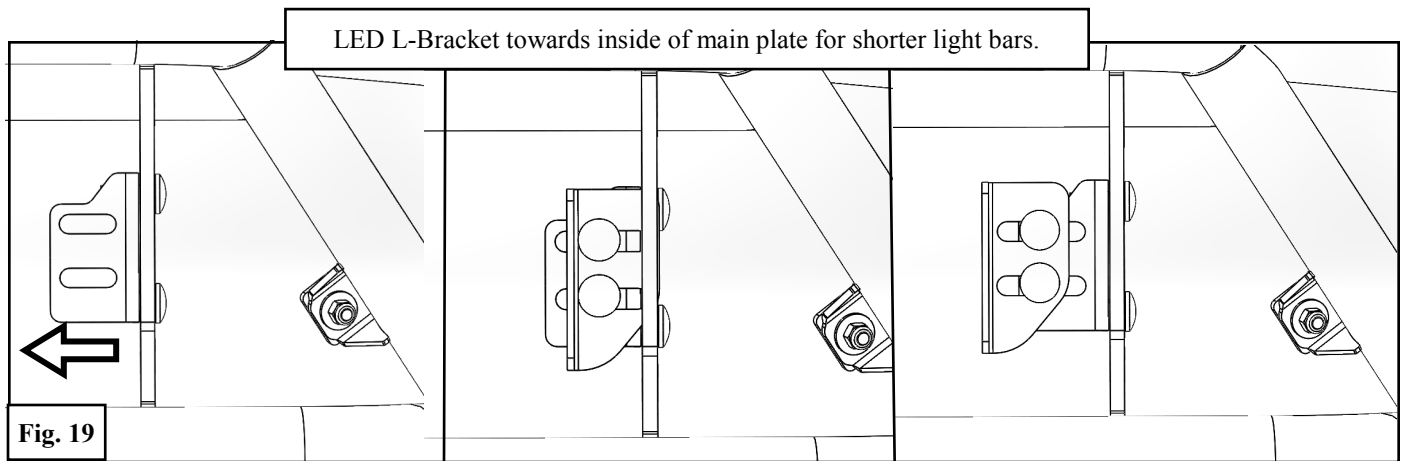
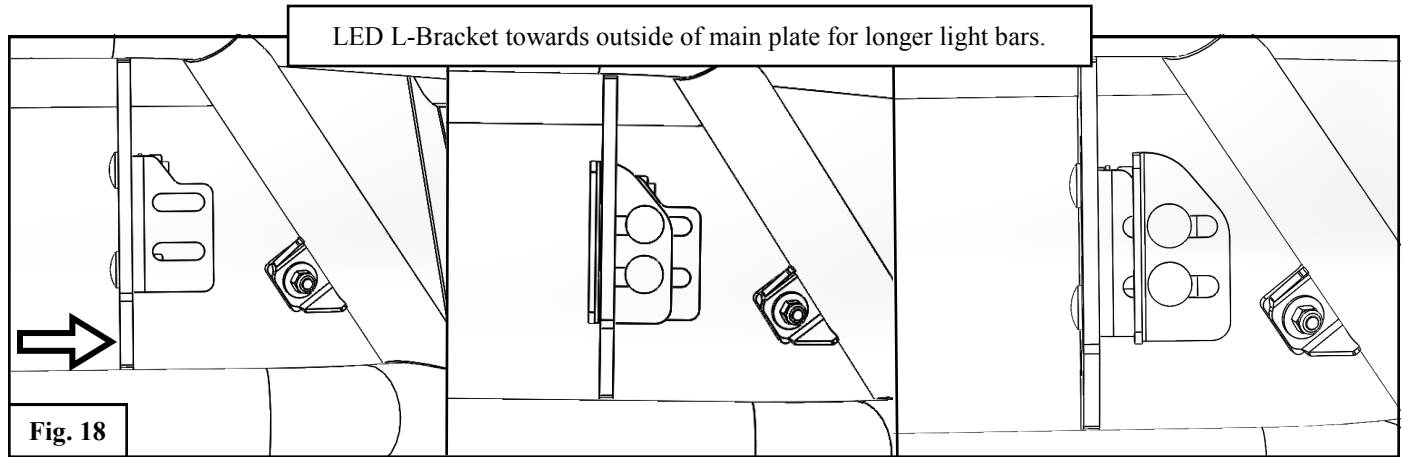
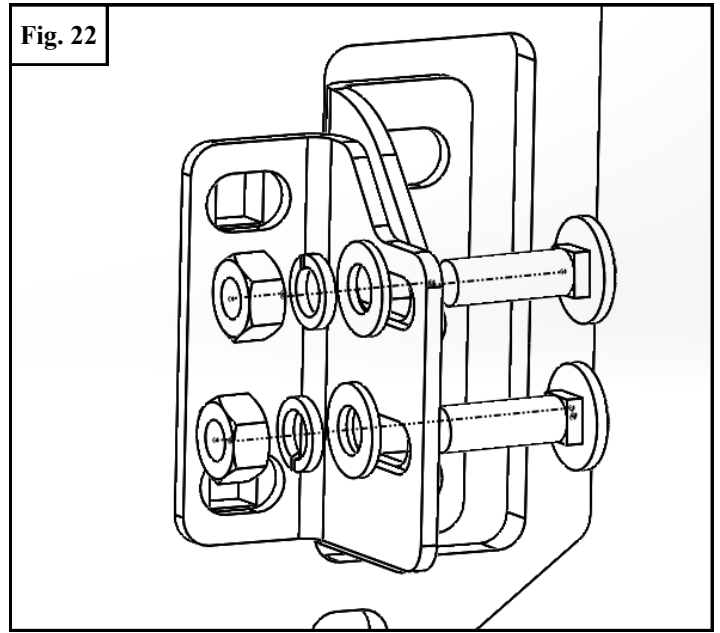
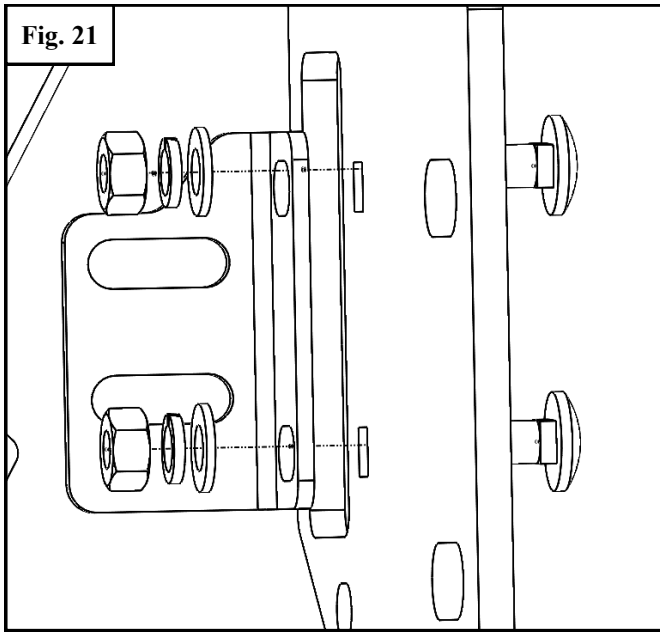
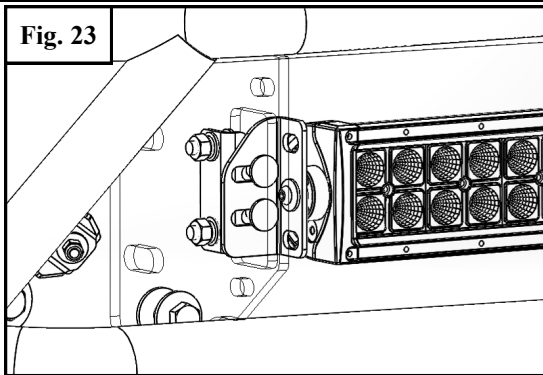

Figure 20 is an example showing the LED brackets adjusted in for the shortest light bar configuration.

14. Using the supplied M8 hardware (22-25), loosely fasten LED L-Brackets (8 & 9) to main plate. See **Figure 12**.
15. Using the supplied M8 hardware (22-25), loosely fasten LED Slider Bracket (6 & 7) to LED L-Bracket. See **Figure 21-22**.



16. Using hardware included in the LED light bar hardware kit, fasten light bar to bracket according to **Figures 23 & 24**.
17. Position light bar as desired and tighten all M8 hardware to 15-18 ft-lbs.



Single "Double Row" Light Bar Configuration

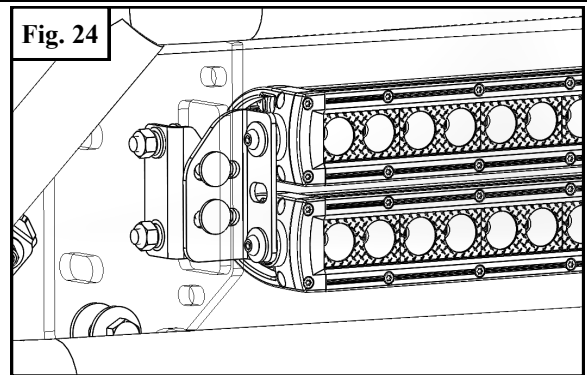

Double "Single Row" Light Bar Configuration

18. Position the meshed corner covers (10 & 11) as seen in **Figures 16 & 17**.

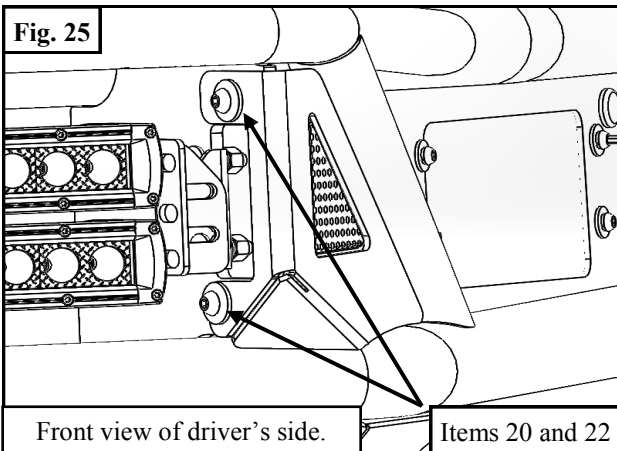

Front view of driver's side.

Items 20 and 22

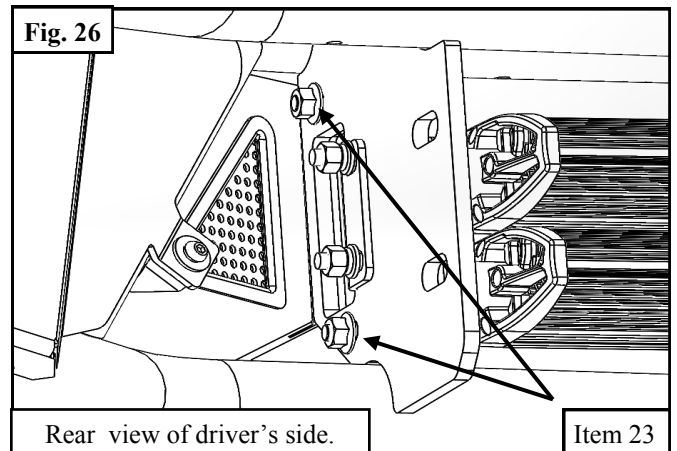

Rear view of driver's side.

Item 23

19. Using M8 serrated flange hex nuts (Item 27), fasten corner cover into position. The serration on the nut should lock the nut in position allowing the installer to tighten button head bolts from the front using a 5mm Allen wrench. See **Figure 26**.

20. Next, install bumper on vehicle according to steps 9 to 11. Torque M8 hardware to 15-18 ft-lbs. , M10 hardware to 55-60 ft-lbs and M12 hardware to 65-70 ft-lbs

Installation Complete



WESTIN

Check out a selection of off-road bumpers offered in our online store.