

INSTALLATION INSTRUCTIONS

OUTLAW NERF STEP BARS



APPLICATION:
2020 Jeep Gladiator
PART NUMBER:
58-54165

CONTENT			
ITEM	QUANTITY	DESCRIPTION	TOOLS NEEDED
1	1	OUTLAW NERF STEP BAR DRIVER SIDE	RATCHET
2	1	OUTLAW NERF STEP BAR PASSENGER SIDE	TORQUE WRENCH
3	1	FRONT MOUNTING BRACKET DRIVER SIDE	10MM SOCKET
4	1	FRONT MOUNTING BRACKET PASSENGER SIDE	13MM SOCKET
5	1	CENTER MOUNTING BRACKET DRIVER SIDE	13MM WRENCH
6	1	CENTER MOUNTING BRACKET PASSENGER SIDE	SOCKET EXT.
7	1	REAR MOUNTING BRACKET DRIVER SIDE	ALLEN WRENCH
8	1	REAR MOUNTING BRACKET PASSENGER SIDE	
9	3	SUPPORT BRACKET DRIVER SIDE	
10	3	SUPPORT BRACKET PASSENGER SIDE	
11	6	M8 EXTRUDED U-NUT (YELLOW ZINC)	
12	24	M8 HEX HEAD CAP SCREW (YELLOW ZINC)	
13	24	M8 SPLIT LOCK WASHER (YELLOW ZINC)	
14	18	M8 HEX NUT (YELLOW ZINC)	
15	42	M8 FLAT WASHER (YELLOW ZINC)	
16	12	M6 HEX NUT (YELLOW ZINC)	
17	12	M6 FLAT WASHER (YELLOW ZINC)	
18	12	M6 SPLIT LOCK WASHER (YELLOW ZINC)	
19	12	M6 CARRIAGE BOLT (BLACK ZINC)	

ANTI-SEIZE LUBRICANT MUST BE USED ON ALL STAINLESS STEEL FASTENERS TO PREVENT THREAD DAMAGE AND GALLING

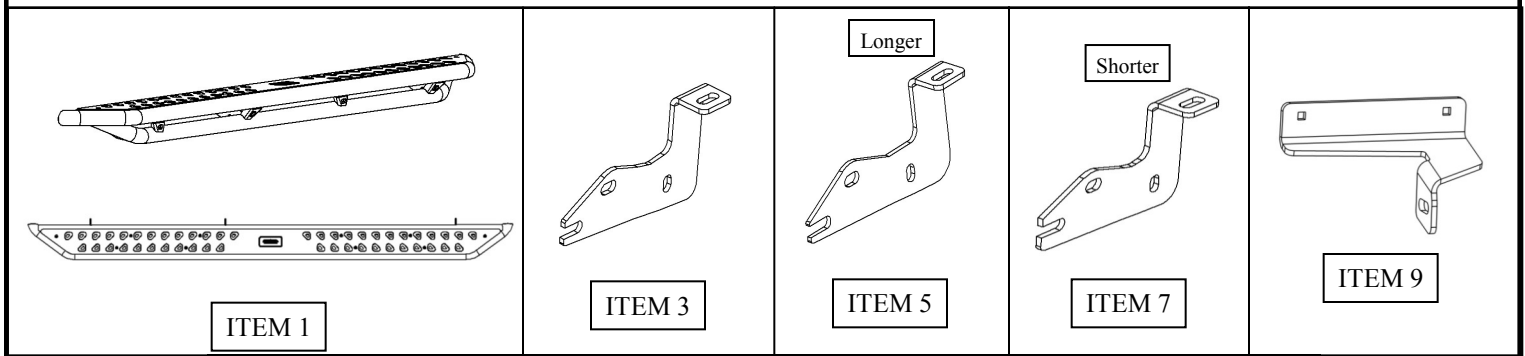

NOTE: DRIVER SIDE ITEMS SHOWN. PASSENGER SIDE ITEMS ARE OPPOSITES.



PROCEDURE

1. Remove contents from box, verify if all parts listed are present and free from damage. Carefully read and understand all instructions before attempting installation.
Failure to identify damage before installation could lead to a rejection of any claim.
2. Starting at the front mount location, locate (1) Driver Support Bracket (Item 9). Loosely secure brackets, using the supplied M6 hardware as shown in **Figure 1 and Figure 2**.

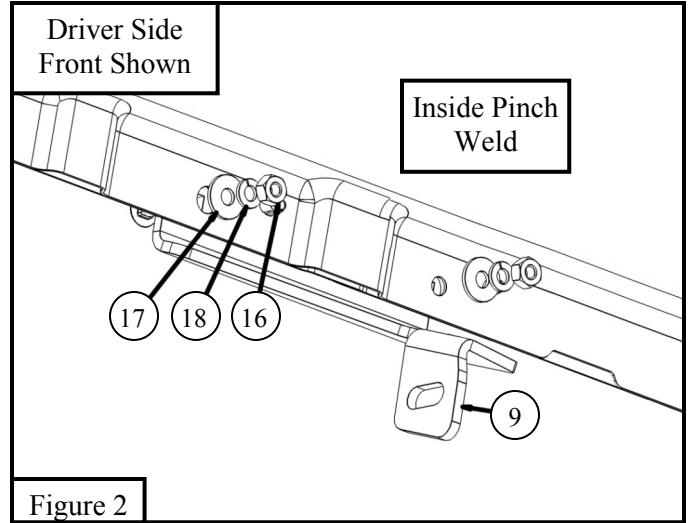
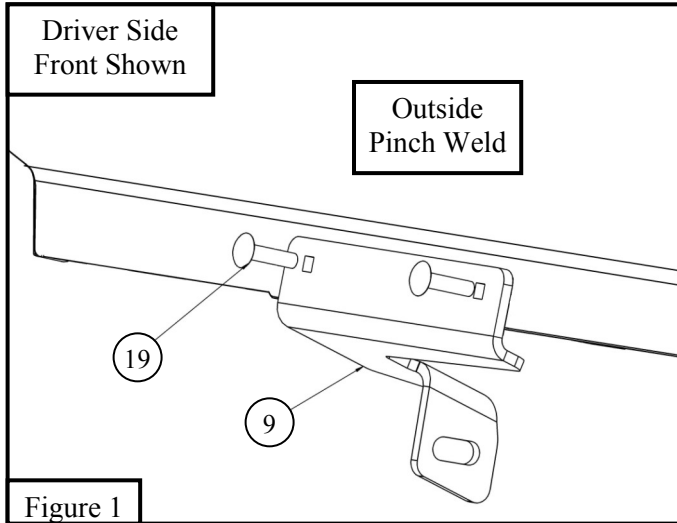

3. Starting on the drivers side loosely install Rear and Center brackets. Installation is similar to Front Mounting bracket. Please refer to **Figure 3 and Figure 5 and 6** for bracket orientation and location.
4. Locate (1) Nerf Step Bar and loosely secure it onto the previously installed rear and center brackets using the provided M8 hardware. Partially insert M8 hardware into board and slide the slotted bracket onto the bolt. See **Figure 4**.
5. Torque the bolts as far as they can go while still having adjustment.
6. Then locate (1) Front Driver Side Mounting Bracket (Item 3). Loosely secure bracket to vehicle and previously installed support bracket using the supplied M8 hardware as shown in **Figure 3**. *[Note: If a threaded hole is not present use the supplied M8 U-Nut Clip (Item 11)].*

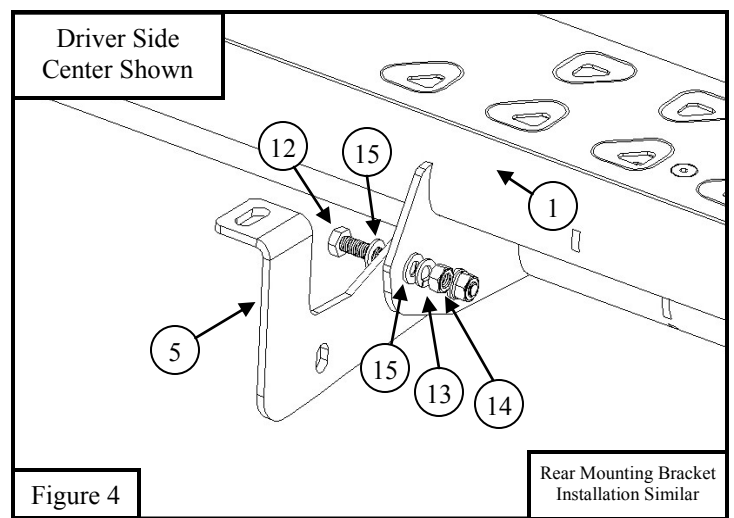
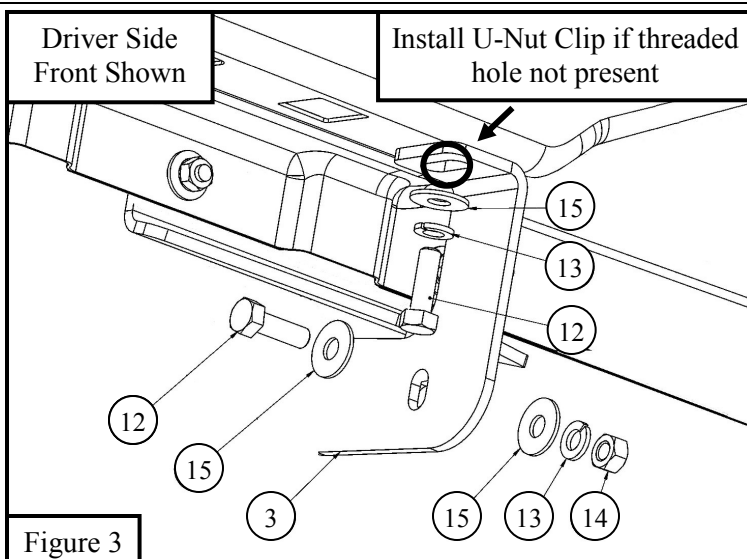

7. Loosely install Front Mounting Bracket with supplied M8 hardware. *Note: Front Mounting Bracket install is similar to Center and Rear Mounting Bracket.*
8. Repeat steps 2 - 7 for passenger side.
9. Align running boards and brackets to desired positioning then torque and tighten all: M6 Hardware to 7 ft-lbs, M8 hardware to 16 ft-lbs.

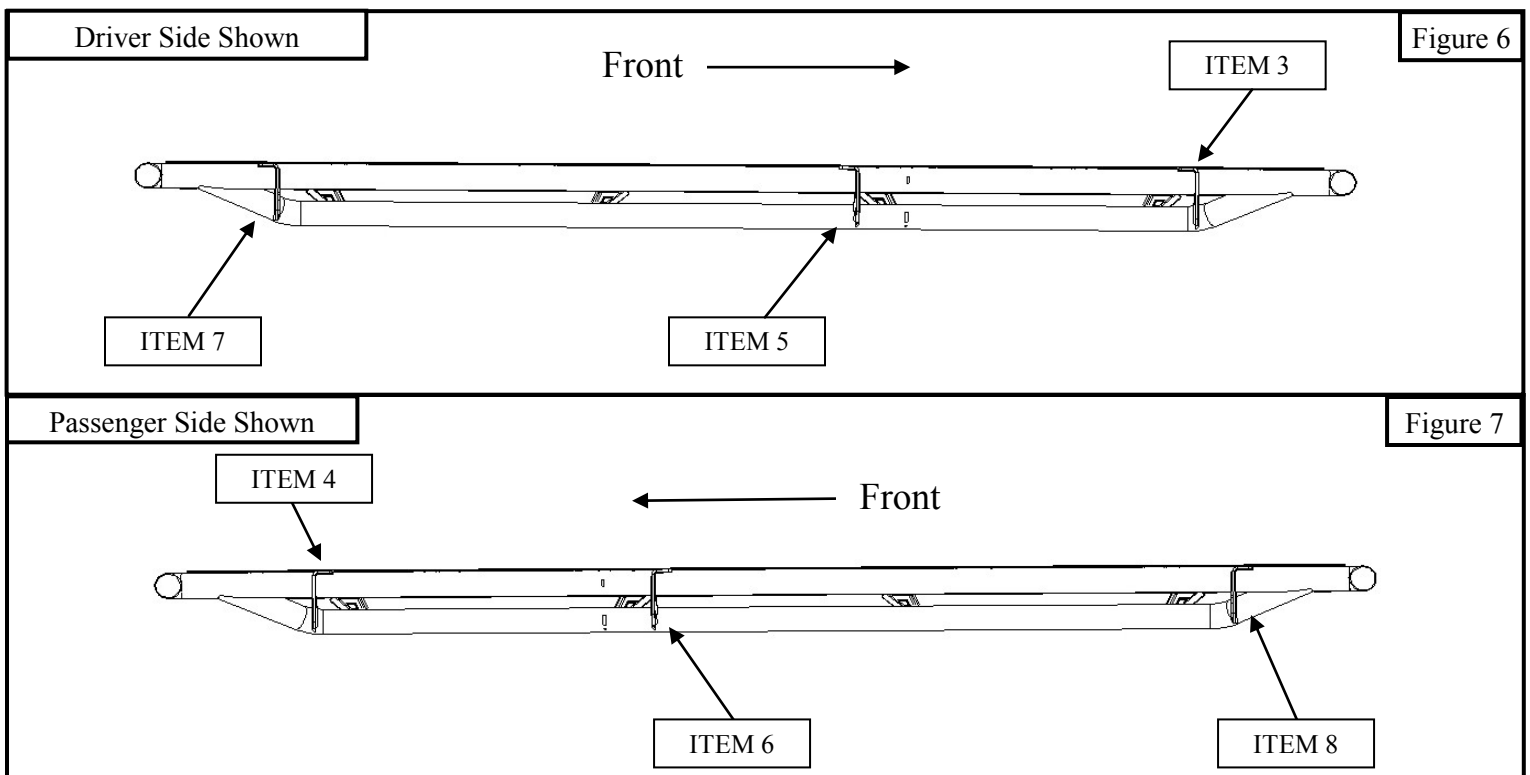

INSTALLATION COMPLETE



CARE INSTRUCTIONS

- REGULAR WAXING IS RECOMMENDED. DO NOT USE ANY TYPE OF POLISH OR WAX THAT MAY CONTAIN ABRASIVES.
- STAINLESS STEEL PRODUCTS CAN BE CLEANED WITH MILD SOAP AND WATER. STAINLESS STEEL POLISH SHOULD BE USED TO POLISH SMALL SCRATCHES.
- GLOSS BLACK FINISHES SHOULD BE CLEANED WITH MILD SOAP AND WATER.

WESTiN