

INSTALLATION INSTRUCTIONS

OUTLAW NERF STEP BARS



APPLICATION:
2019 Ram 1500 Crew Cab (Excl. 2019 Ram 1500 Classic)
PART NUMBER:
58-54085

CONTENT			
ITEM	QUANTITY	DESCRIPTION	TOOLS NEEDED
1	1	DRIVER STEP BAR ASSEMBLY	13MM SOCKET
2	1	PASSENGER STEP BAR ASSEMBLY	13MM WRENCH
3	1	DRIVER FRONT MOUNTING BRACKET	16MM SOCKET
4	1	PASSENGER FRONT MOUNTING BRACKET	16MM WRENCH
5	2	CENTER MOUNTING BRACKET	RATCHET
6	2	REAR MOUNTING BRACKET	TORQUE WRENCH
7	6	UNIVERSAL BRACKET	
8	24	M8 SPLIT LOCK WASHER	
9	24	M8 FLAT WASHER	
10	24	M8 HEX NUT	
11	6	M8 CARRIAGE BOLT	
12	12	M10 HEX HEAD CAP SCREW	
13	12	M10 BELLVILLE WASHER	
14	12	M10 SERRATED FLANGE NUT	

ANTI-SEIZE LUBRICANT MUST BE USED ON ALL STAINLESS STEEL FASTENERS TO PREVENT THREAD DAMAGE AND GALLING

Passenger Side Opposite

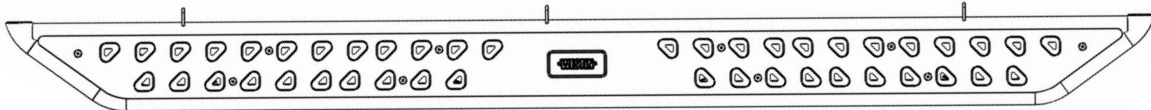

ITEM 1

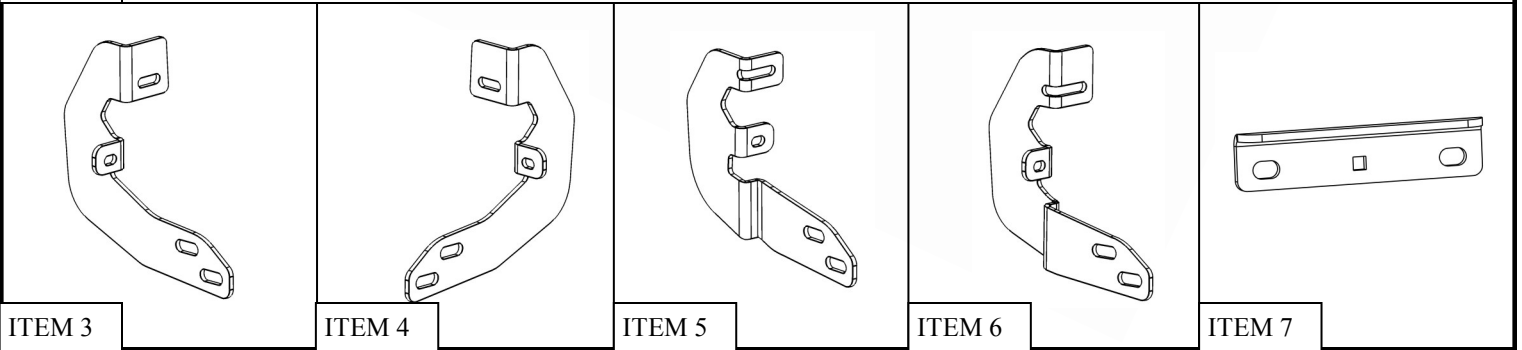

PROCEDURE

1. Remove contents from box, verify if all parts listed are present and free from damage.
Carefully read and understand all instructions before attempting installation.
Failure to identify damage before installation could lead to a rejection of any claim.

2. Preassemble the Mounting Brackets (3-7). Do not tighten hardware at this time. See **Figure 1**.

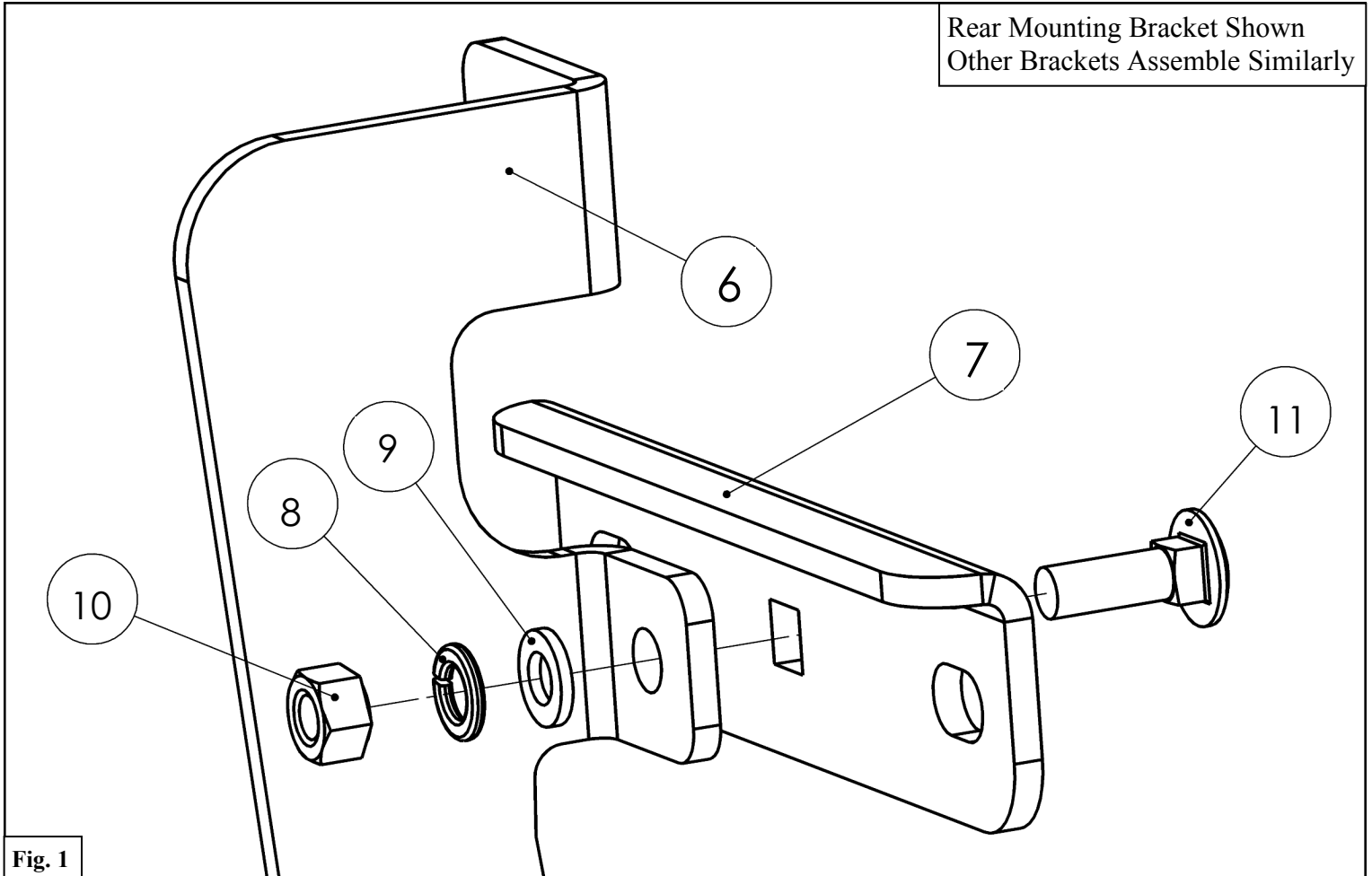

3. Starting on the passenger side of the vehicle, locate the 3 mounting locations on the rocker panel.

Note A: The rear mounting location is shown in **Figure 2**.

Other mounting locations are similar.

Note B: The lower two studs on the rocker panel have a thick coat of paint on them. When installing the M8 hex nuts, apply extra pressure to start. If necessary, back M8 hex nuts off the studs to clear build up.

See **Figure 2**.

Rear Mounting Location Shown
Other Mounting Locations are Similar

Fig. 2

4. At the rear mounting location, loosely install Rear Mounting Bracket (6) with preassembled Universal Bracket (7) using the supplied M8 hardware. See **Figures 3 & 4**.

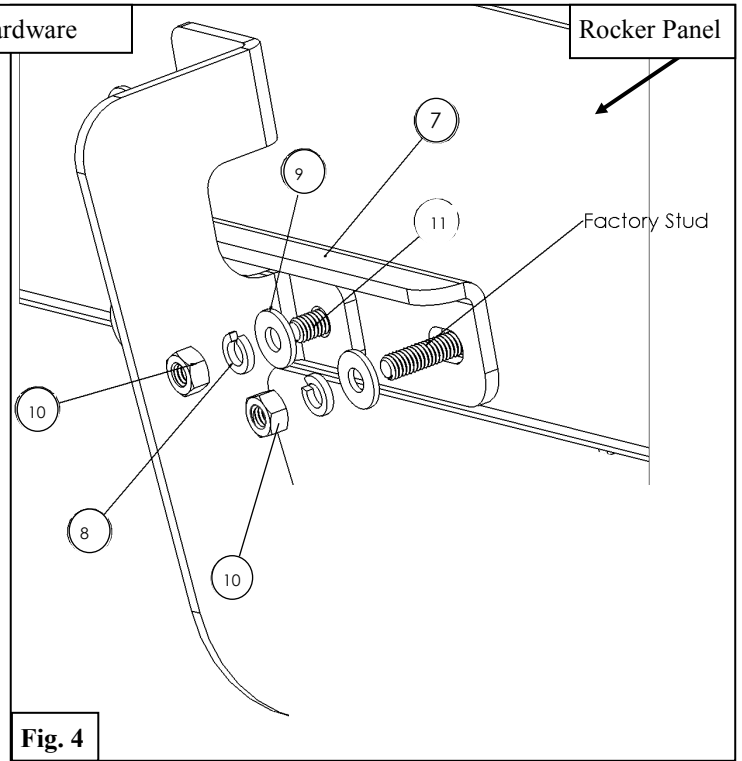
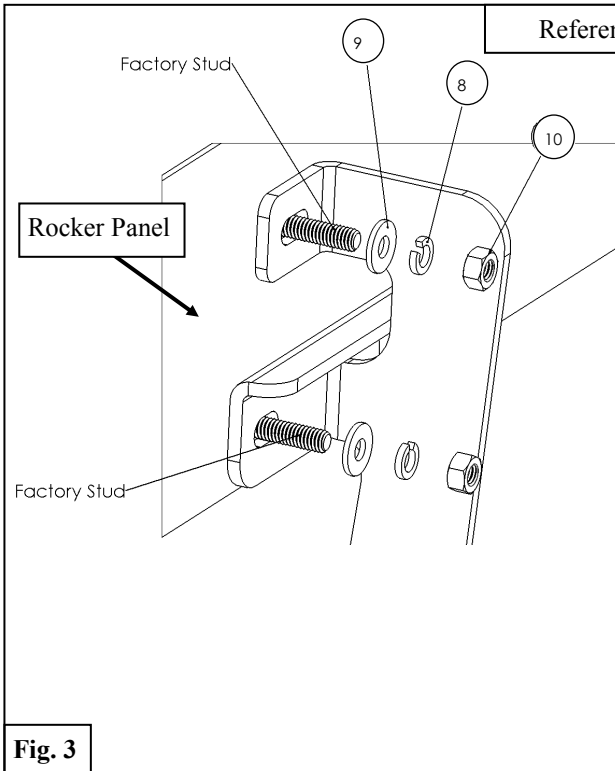

- At the center passenger mounting location, loosely install Center Mount Bracket (5) with preassembled Universal Bracket (7) using the supplied M8 hardware. See **Figures 5 & 6**.

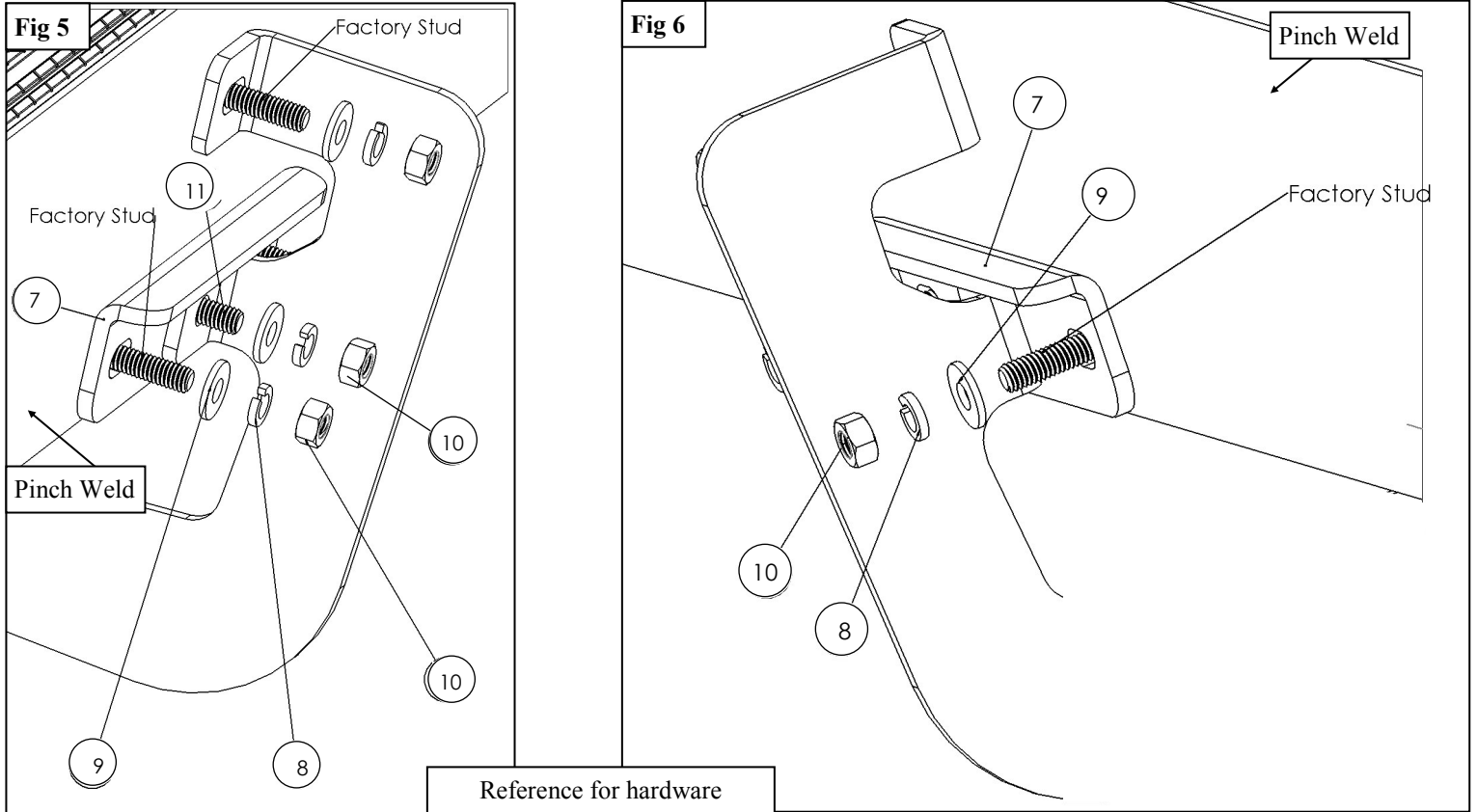

- At the front passenger mounting location, loosely install Front Mounting Brackets (3 & 4) with preassembled Universal Mounting Bracket (7). **Note:** Installation is similar to Rear Mounting Bracket
- Repeat **Steps 4-7** on the driver side of the vehicle.

8. For step bar installation, use the supplied M10 Hardware to loosely secure the step bar to the preinstalled brackets. See **Figures 7 & 8**. *Note: All brackets install similarly to step bar.*
9. Align and adjust the step bars and brackets as needed, then fully tighten all hardware: M8 to 18 ft-lbs, M10 to 38 ft-lbs.

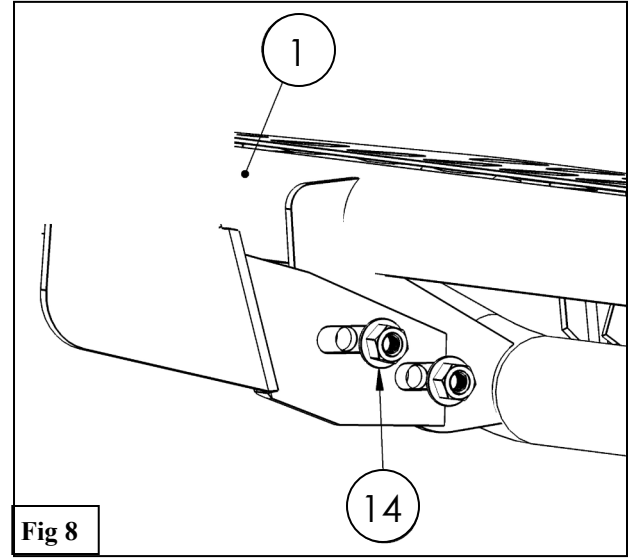
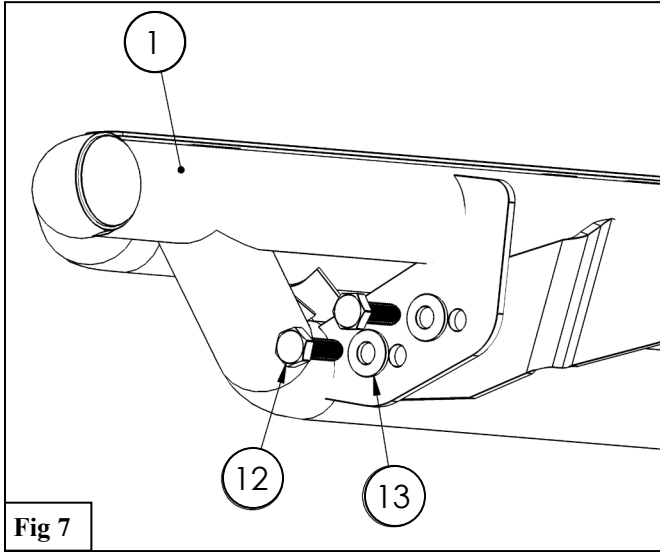

BRACKET LOCATION REFERENCE

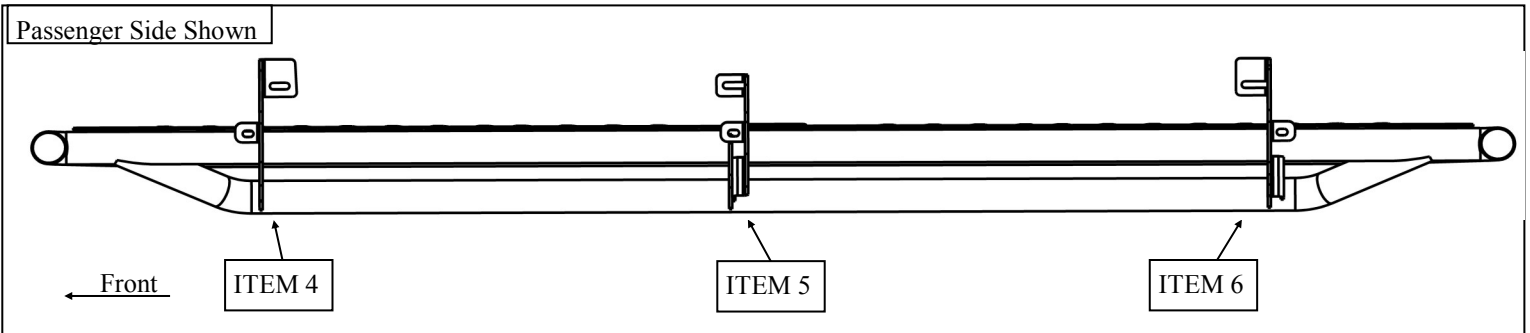
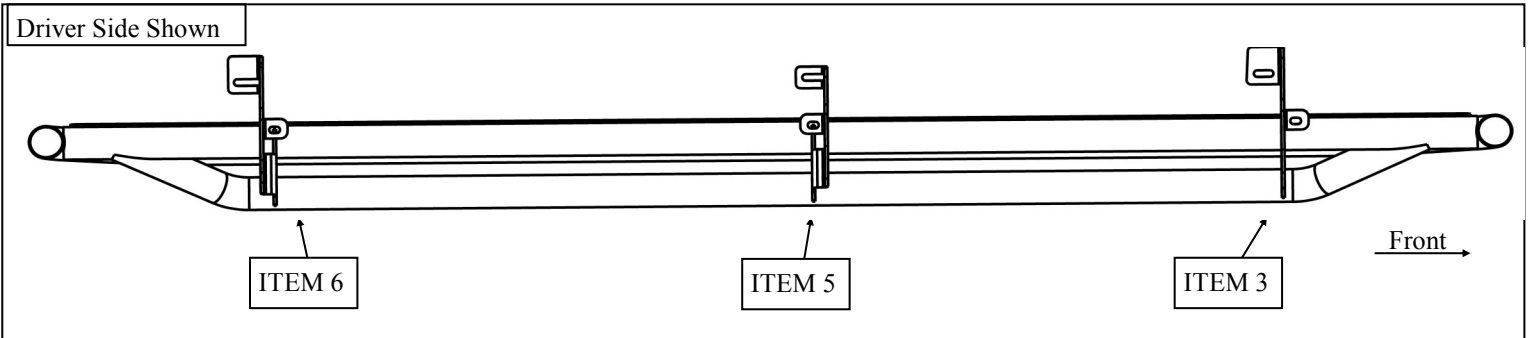

INSTALLATION COMPLETE



CARE INSTRUCTIONS

- REGULAR WAXING IS RECOMMENDED. DO NOT USE ANY TYPE OF POLISH OR WAX THAT MAY CONTAIN ABRASIVES.
- STAINLESS STEEL PRODUCTS CAN BE CLEANED WITH MILD SOAP AND WATER. STAINLESS STEEL POLISH SHOULD BE USED TO POLISH SMALL SCRATCHES.
- GLOSS BLACK FINISHES SHOULD BE CLEANED WITH MILD SOAP AND WATER

WESTiN



WARNING



Failure to follow these instructions could lead to death, personal injury, and / or property damage.

Failure to follow these instructions could lead to death, personal injury, and / or property damage.

FASTENERS:

All Westin supplied fasteners must be utilized and installed in accordance with the installation instructions and apply torque to the specifications as defined. **DOUBLE CHECK ALL FASTENERS BEFORE INITIAL USE, AND PERIODICALLY IN THE FUTURE TO ENSURE PROPER FUNCTION AND SAFETY.**

DRILLING:

Most Westin products do not require drilling for installation. If drilling is defined as required, use caution when drilling a vehicle. **FAILURE TO REVIEW AN AREA TO BE DRILLED MAY RESULT IN PERSONAL INJURY AND/OR INJURY TO OTHERS AS WELL AS VEHICLE DAMAGE.**

EYE PROTECTION:

ALWAYS WEAR SAFETY GLASSES OR GOGGLES DURING THE INSTALLATION PROCESS TO AVOID PERSONAL INJURY.

MAXIMUM TOWING/CARRYING CAPACITY: (if applicable)

The Westin Receiver Hitches will have a visible tow rating label affixed directly on the product. User should never exceed the vehicle manufacturers maximum tow and weight rating regardless of the capacity of the hitch. **FAILURE TO FOLLOW THESE GUIDELINES WILL VOID THE WESTIN WARRANTY AND MAY RESULT IN PERSONAL INJURY AND/OR INJURY TO OTHERS AS WELL AS VEHICLE DAMAGE.**



Learn more about running boards and step bars we have.