

INSTALLATION INSTRUCTIONS

OUTLAW NERF STEP BARS



APPLICATION:

2014-2018 Chevrolet/GMC Silverado/Sierra 1500 Crew and Double Cab; 2019 Silverado LD/Sierra Limited Double Cab; 2015-2019 Chevrolet/GMC Silverado/Sierra 2500/3500 Crew and Double Cab

PART NUMBER:

58-53715, 58-53725

GAS MODEL INSTALLATION SHEET FOR DIESEL MODELS PROCEED TO PAGE 6

CONTENT			
ITEM	QUANTITY	DESCRIPTION	TOOLS NEEDED
1,2	2	OUTLAW STEP BAR (1-DRIVER, 2-PASSENGER)	13MM SOCKET
3	4	MOUNTING BRACKET	13MM WRENCH
4	1	FLANGE MOUNTING BRACKET LEFT	16MM SOCKET
5	1	FLANGE MOUNTING BRACKET RIGHT	
6	12	M8 U-CLIP	16MM WRENCH
7	12	M8 SPLIT LOCK WASHER	RATCHET
8	12	M8 FLAT WASHER	TORQUE WRENCH
9	12	M8 HEX HEAD SCREW	
10	12	M10 HEX HEAD SCREW	
11	12	M10 BELLVILLE WASHER	
12	12	M10 SERRATED FLANGE NUT	

ANTI-SEIZE LUBRICANT MUST BE USED ON ALL STAINLESS STEEL FASTENERS TO PREVENT THREAD DAMAGE AND GALLING

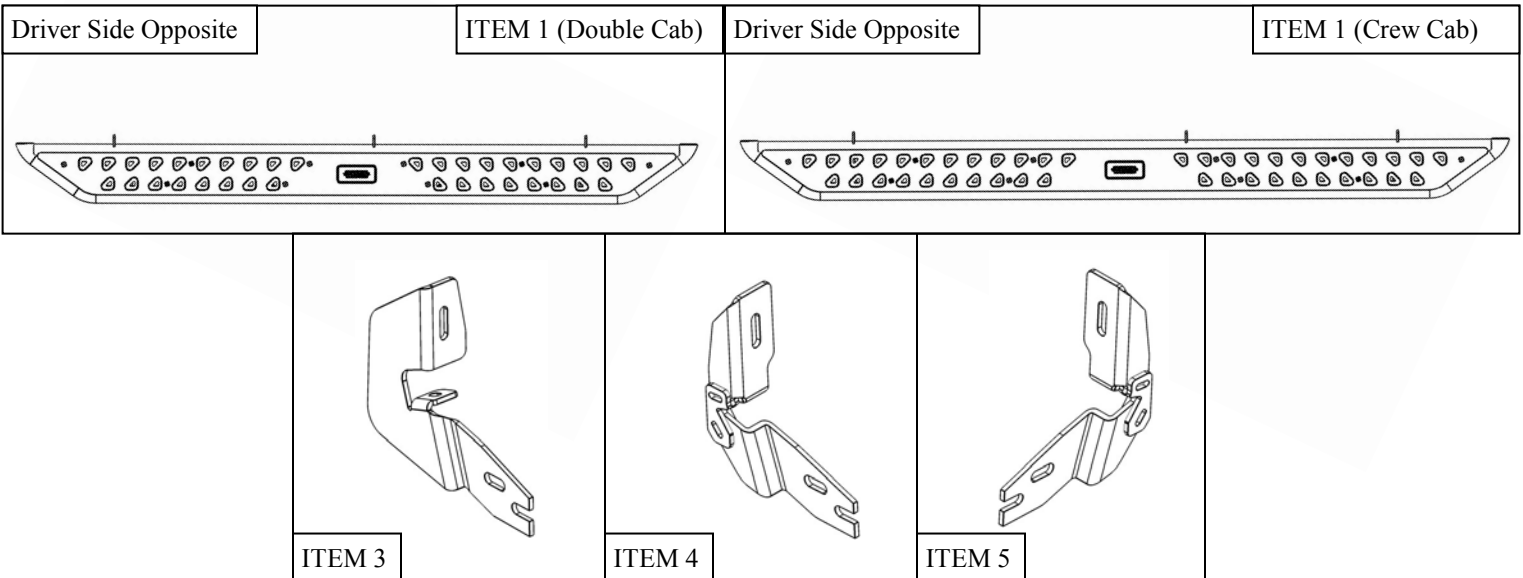

PROCEDURE

1. Remove contents from box, verify if all parts listed are present and free from damage.
Carefully read and understand all instructions before attempting installation.
Failure to identify damage before installation could lead to a rejection of any claim.
2. Starting on the driver side, remove the rubber plugs located on the rocker panel at each mounting location. See **Figure 1**.
3. At each bracket mounting location on the pinch weld there should either be a welded factory nut or a hole. If there is a factory welded nut present, then the M8 U-Nut Clip (Item 6) will not be used at that location. See **Figure 2**. If there is a hole present then (Item 6) will be used. See **Figure 3**

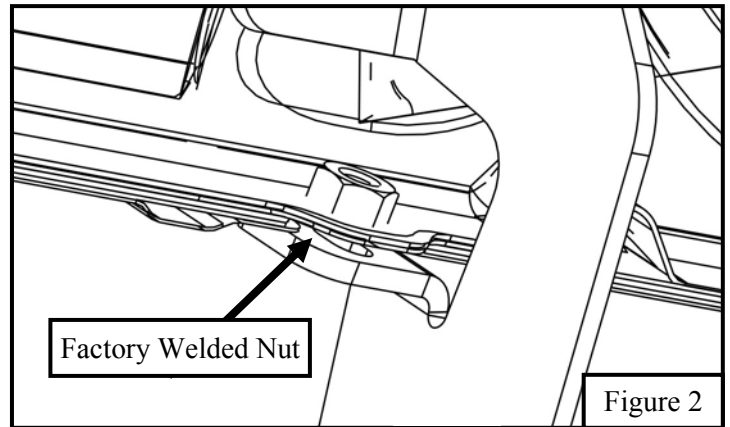
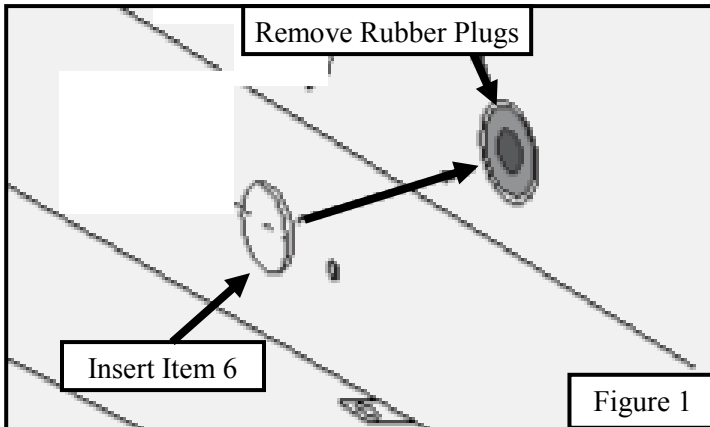

4. In order to place the brackets in the correct location use the figures in **Page 3** together with the instructions below.
5. Insert (1) M8 u-nut clip (Item 6) into the hole where the rubber plug was removed. Clip (1) M8 u-nut clip onto pinch weld if no factory welded nut is present. Locate (1) Mounting Bracket (Item 3) and loosely secure it to the rocker panel using the provided hardware: (2) M8 hex head screw, (2) M8 flat washer, and (2) M8 lock washer. See **Figure 3**.
6. Repeat **Step 5** for every other bracket mounting location that uses Mounting Bracket (Item 3).
7. Locate (1) Flange Mounting Bracket Left (Item 4) and loosely secure it to the rocker panel using (2) M8 hex head screw, (2) M8 flat washer, (2) M8 lock washer and (2) M8 u-nut clip. Repeat for location using (Item 5), See **Figure 4**.

(Note: Refer to **Page 3** for bracket orientation figures.)

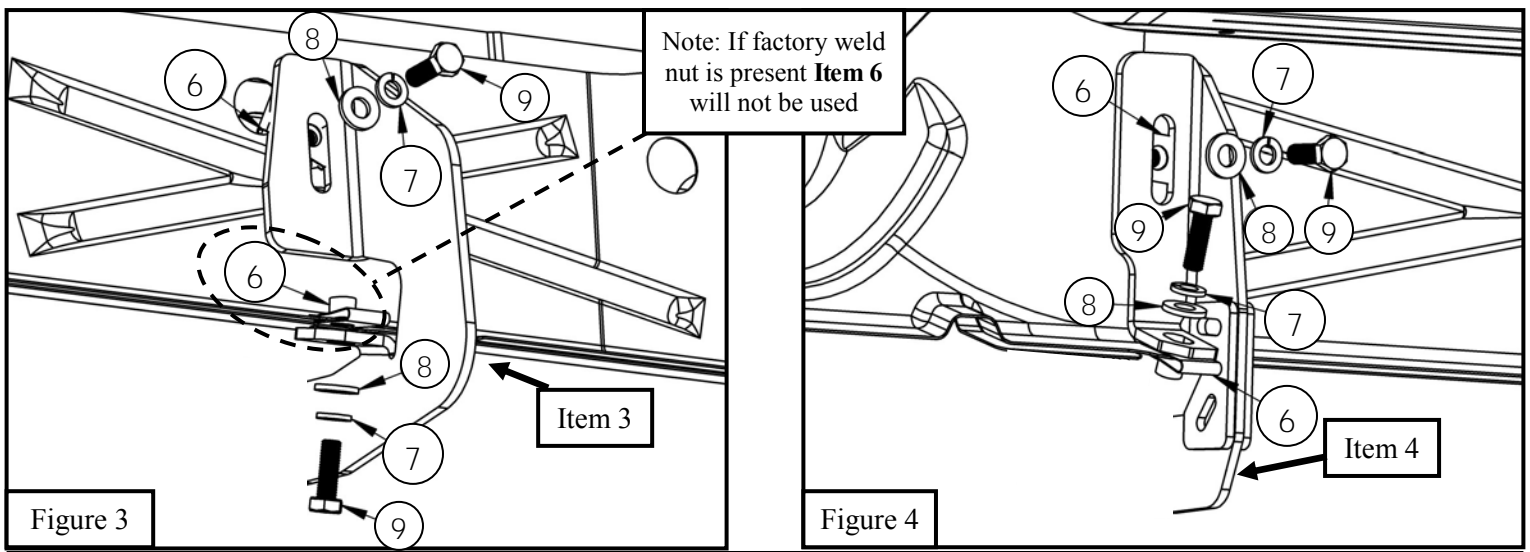

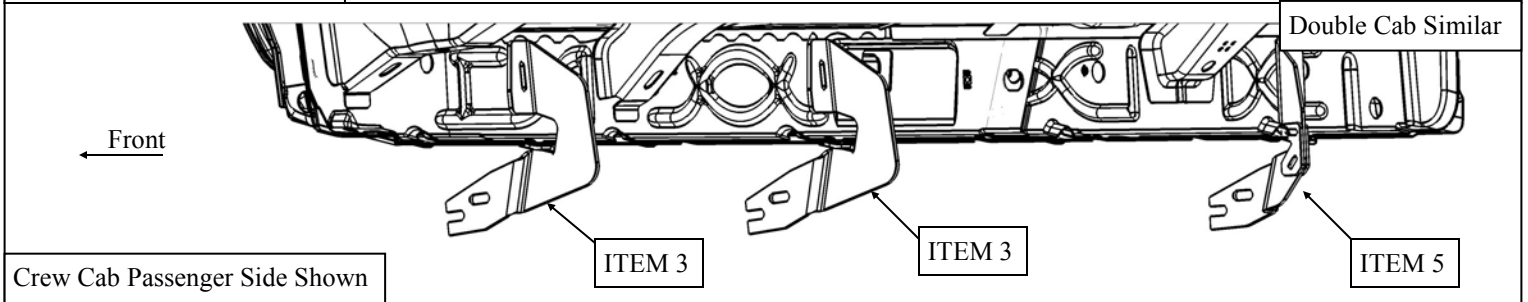
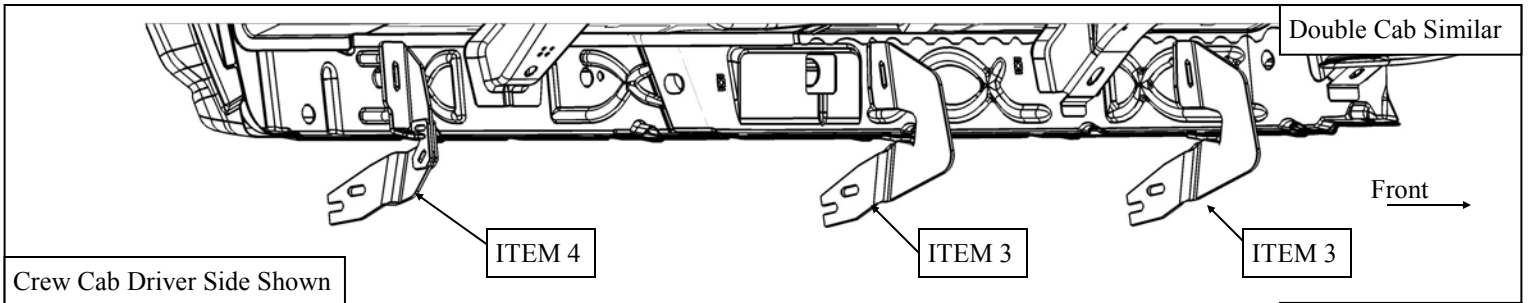

8. For step bar installation, use the supplied M10 Hardware to loosely secure the step bar to the preinstalled brackets. See **Figures 5 & 6**. (**Note:** Mounting Bracket (Item 3) is shown; bar installs to other brackets similarly.)
9. Align and adjust the step bars and brackets as needed, then fully tighten all hardware: M8 to 18 ft-lbs, M10 to 38 ft-lbs.

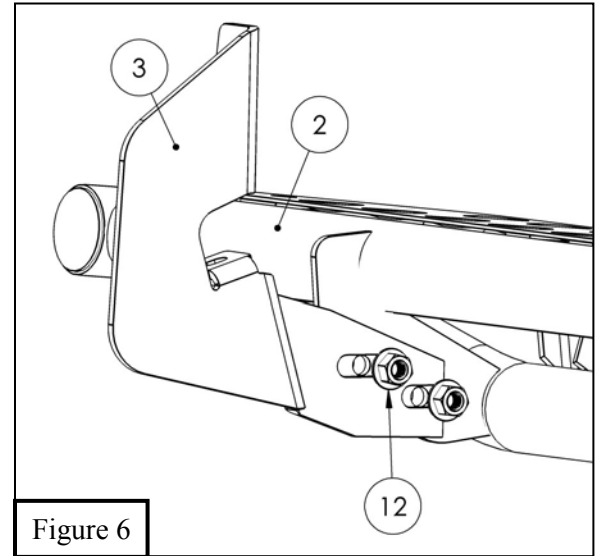
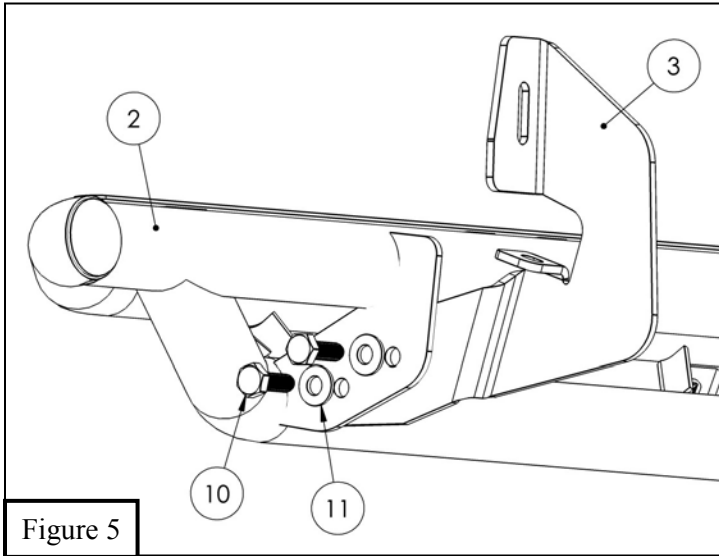

INSTALLATION COMPLETE



Sierra 2500 Crew Cab Shown

CARE INSTRUCTIONS

- REGULAR WAXING IS RECOMMENDED. DO NOT USE ANY TYPE OF POLISH OR WAX THAT MAY CONTAIN ABRASIVES.
- STAINLESS STEEL PRODUCTS CAN BE CLEANED WITH MILD SOAP AND WATER. STAINLESS STEEL POLISH SHOULD BE USED TO POLISH SMALL SCRATCHES.
- GLOSS BLACK FINISHES SHOULD BE CLEANED WITH MILD SOAP AND WATER



WARNING



Failure to follow these instructions could lead to death, personal injury, and / or property damage.

Failure to follow these instructions could lead to death, personal injury, and / or property damage.

FASTENERS:

All Westin supplied fasteners must be utilized and installed in accordance with the installation instructions and apply torque to the specifications as defined. **DOUBLE CHECK ALL FASTENERS BEFORE INITIAL USE, AND PERIODICALLY IN THE FUTURE TO ENSURE PROPER FUNCTION AND SAFETY.**

DRILLING:

Most Westin products do not require drilling for installation. If drilling is defined as required, use caution when drilling a vehicle. **FAILURE TO REVIEW AN AREA TO BE DRILLED MAY RESULT IN PERSONAL INJURY AND/OR INJURY TO OTHERS AS WELL AS VEHICLE DAMAGE.**

EYE PROTECTION:

ALWAYS WEAR SAFETY GLASSES OR GOGGLES DURING THE INSTALLATION PROCESS TO AVOID PERSONAL INJURY.

MAXIMUM TOWING/CARRYING CAPACITY: (if applicable)

The Westin Receiver Hitches will have a visible tow rating label affixed directly on the product. User should never exceed the vehicle manufacturers maximum tow and weight rating regardless of the capacity of the hitch. **FAILURE TO FOLLOW THESE GUIDELINES WILL VOID THE WESTIN WARRANTY AND MAY RESULT IN PERSONAL INJURY AND/OR INJURY TO OTHERS AS WELL AS VEHICLE DAMAGE.**



INSTALLATION INSTRUCTIONS

OUTLAW NERF STEP BARS



APPLICATION:

2014-2018 Chevrolet/GMC Silverado/Sierra 1500 Crew and Double Cab; 2019 Silverado LD/Sierra Limited Double Cab; 2015-2019 Chevrolet/GMC Silverado/Sierra 2500/3500 Crew and Double Cab

PART NUMBER:

58-53715, 58-53725

DIESEL MODEL INSTALLATION SHEET

FOR GAS MODELS GO BACK TO PAGE 1

CONTENT			
ITEM	QUANTITY	DESCRIPTION	TOOLS NEEDED
1,2	2	OUTLAW STEP BAR (1-DRIVER, 2-PASSENGER)	13MM SOCKET
3	4	MOUNTING BRACKET	13MM WRENCH
4	1	FLANGE MOUNTING BRACKET LEFT	16MM SOCKET
5	1	FLANGE MOUNTING BRACKET RIGHT	
6	12	M8 U-CLIP	16MM WRENCH
7	12	M8 SPLIT LOCK WASHER	RATCHET
8	12	M8 FLAT WASHER	TORQUE WRENCH
9	12	M8 HEX HEAD SCREW	
10	12	M10 HEX HEAD SCREW	
11	12	M10 BELLVILLE WASHER	
12	12	M10 SERRATED FLANGE NUT	

ANTI-SEIZE LUBRICANT MUST BE USED ON ALL STAINLESS STEEL FASTENERS TO PREVENT THREAD DAMAGE AND GALLING

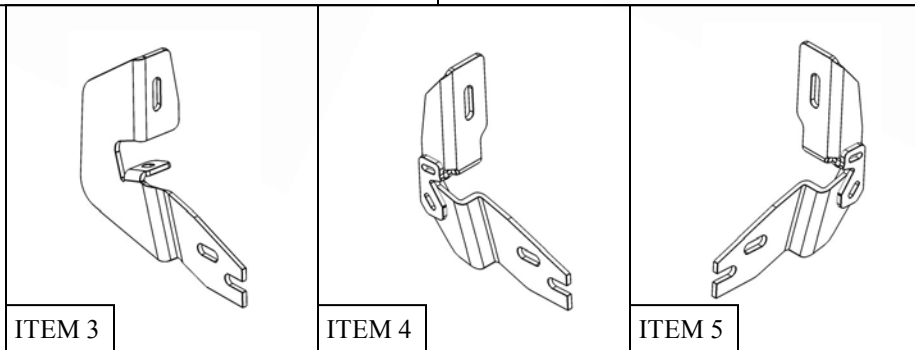
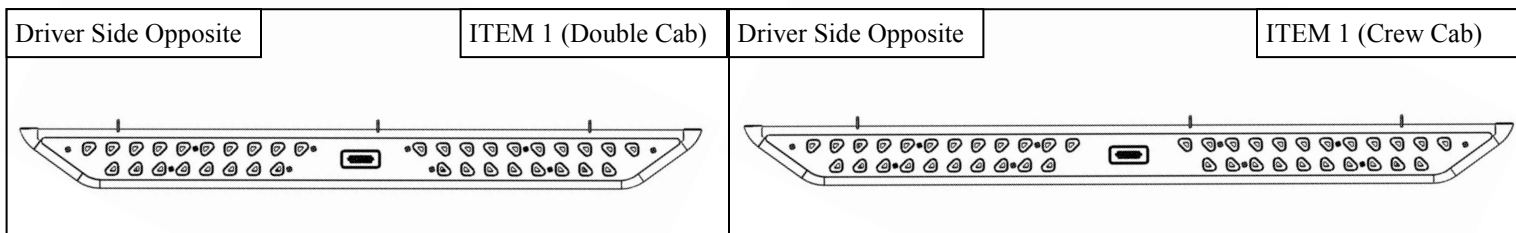

PROCEDURE

1. Remove contents from box, verify if all parts listed are present and free from damage.
Carefully read and understand all instructions before attempting installation.
Failure to identify damage before installation could lead to a rejection of any claim.
2. Starting on the driver side, remove the rubber plugs located on the rocker panel at each mounting location. See **Figure 1**.
3. There may be mounting locations where the rocker panel all ready has welded nuts and the U-Nut Clips (Item 6) will not be needed. Use the provided hardware and mount the brackets utilizing the OE welded nuts.

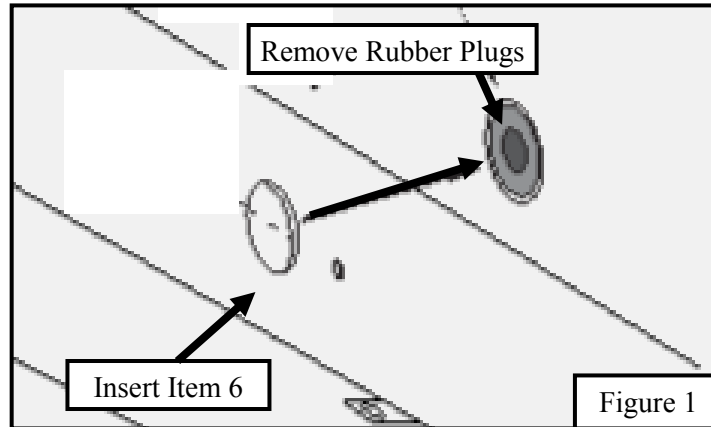

For 2015-2016 MODEL OWNERS please continue to PAGE 9 for instructions on how to drop the DEF tank before proceeding with the bracket installation.

4. In order to place the brackets in the correct location use the figures in **Page 8** together with the instructions below.
5. Insert (1) M8 u-nut clip (Item 6) into the hole where the rubber plug was removed. Clip (1) M8 u-nut clip onto pinch weld. Locate (1) Mounting Bracket (Item 3) and loosely secure it to the rocker panel using the provided hardware: (2) M8 hex head screw, (2) M8 flat washer, and (2) M8 lock washer. See **Figure 3**.
6. Repeat **Step 5** for every other bracket mounting location that uses Mounting Bracket (Item 3).
7. Locate (1) Flange Mounting Bracket Left (Item 4) and loosely secure it to the rocker panel using (2) M8 hex head screw, (2) M8 flat washer, (2) M8 lock washer and (2) M8 u-nut clip. Repeat for location using (Item 5), See **Figure 4**.

(Note: Refer to **Page 8** for bracket orientation figures.)

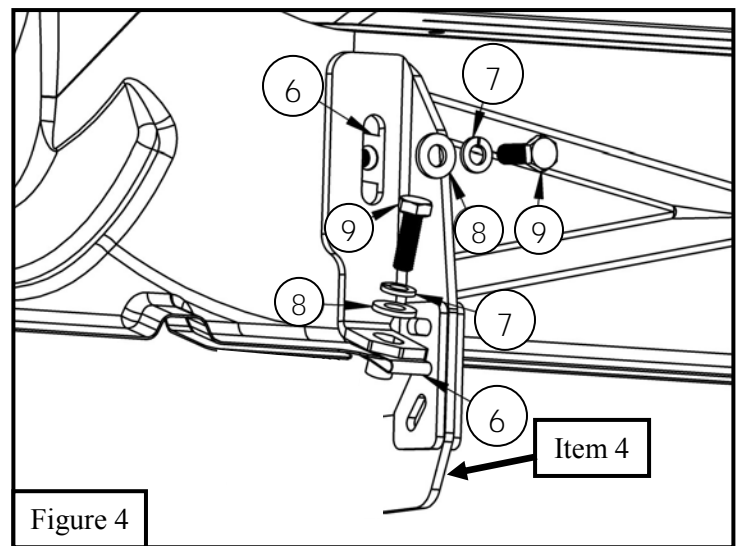
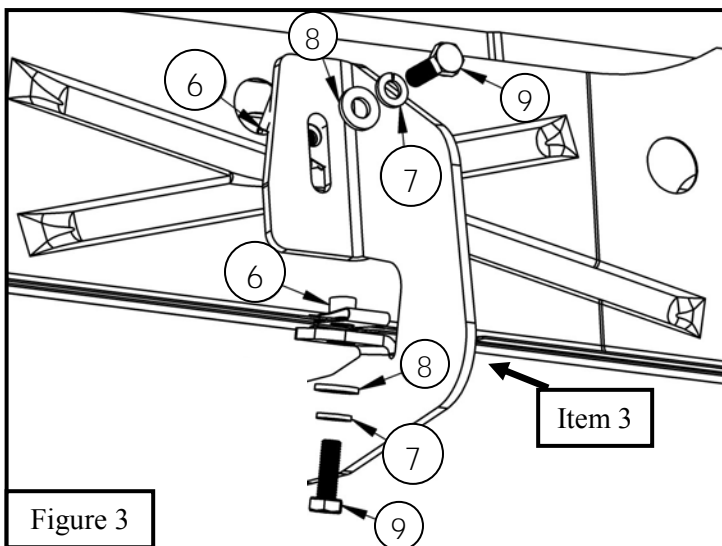

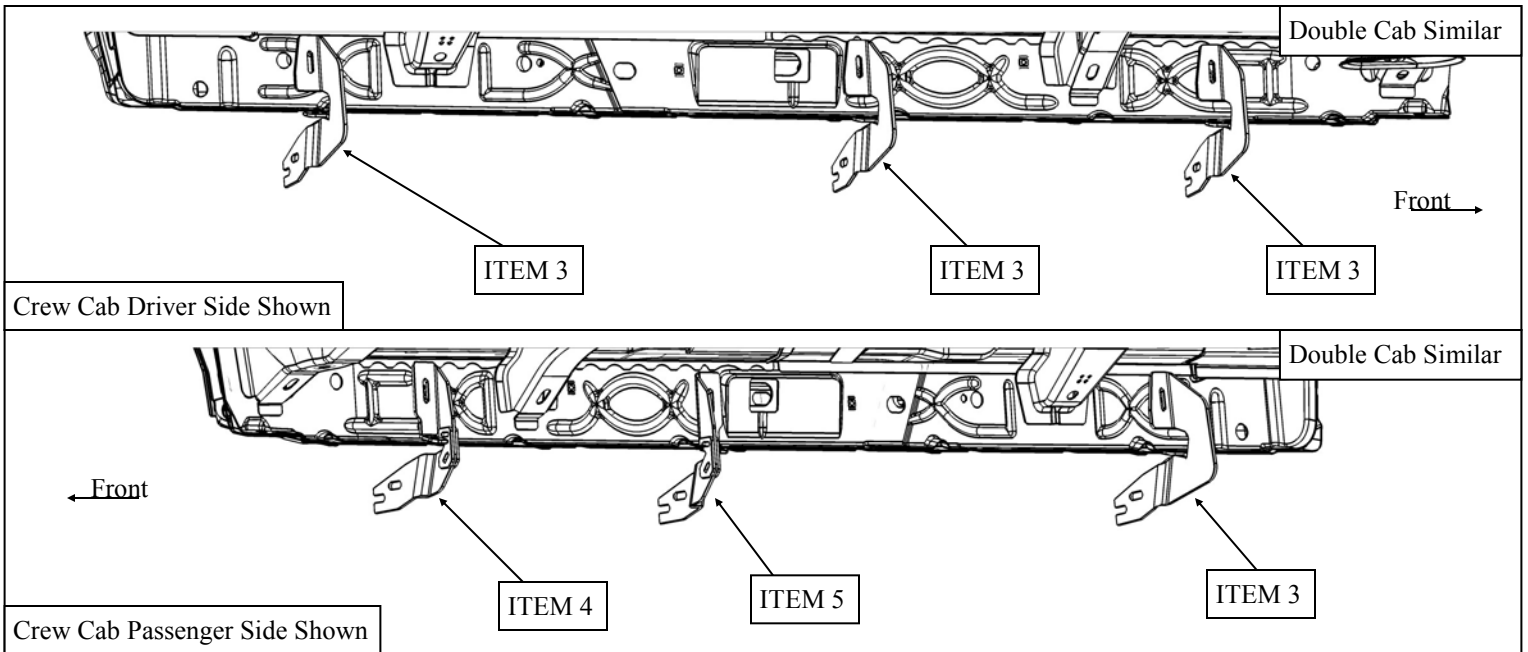

8. For step bar installation, use the supplied M10 Hardware to loosely secure the step bar to the preinstalled brackets. See **Figures 5 & 6**. (Note: Mounting Bracket (Item 3) is shown; bar installs to other brackets similarly.)
9. Align and adjust the step bars and brackets as needed, then fully tighten all hardware: M8 to 18 ft-lbs, M10 to 38 ft-lbs.
10. **2015-2016 model owners reinstall the DEF tank after everything has been fully tightened in the reverse order of the instructions detailed on page 9.**

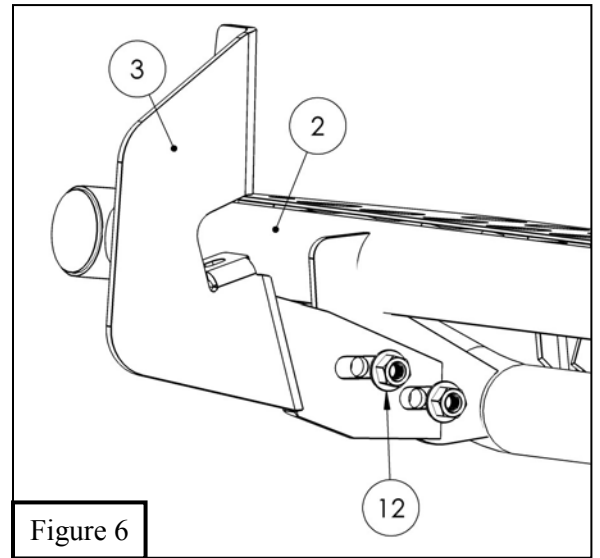
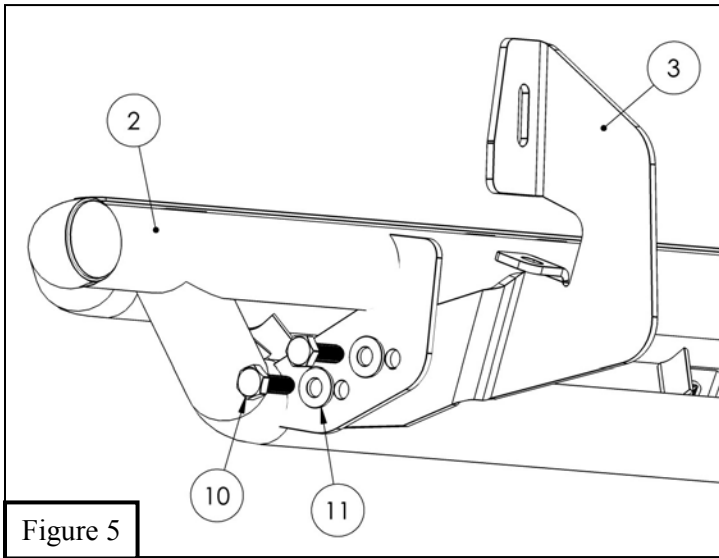

**DEF TANK REMOVAL INSTRUCTIONS FOR 2015-2016
(NOT REQUIRED FOR 2017-2019)**

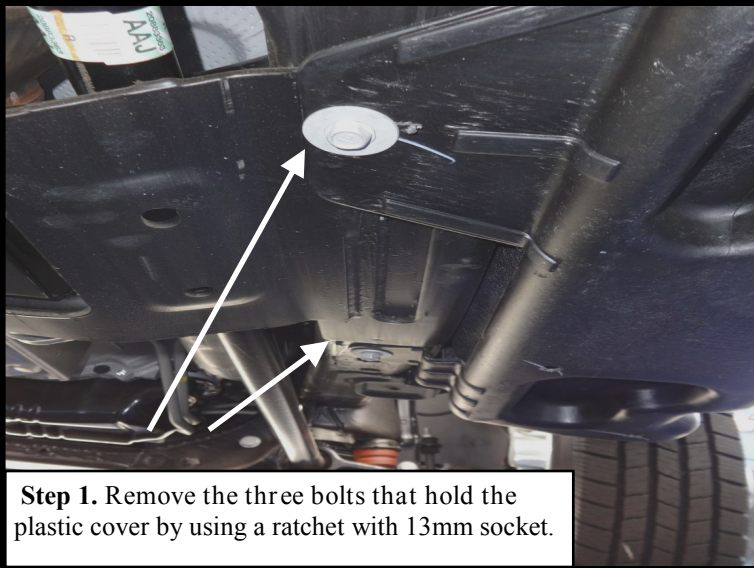

Step 1. Remove the three bolts that hold the plastic cover by using a ratchet with 13mm socket.

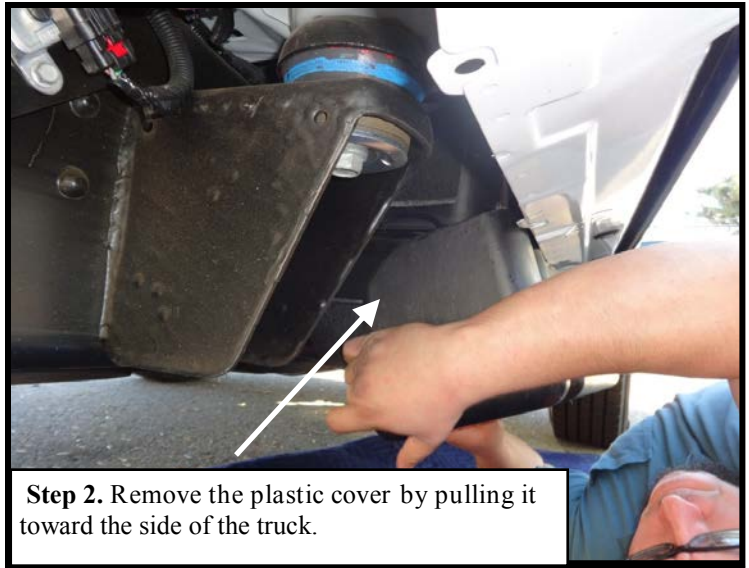

Step 2. Remove the plastic cover by pulling it toward the side of the truck.

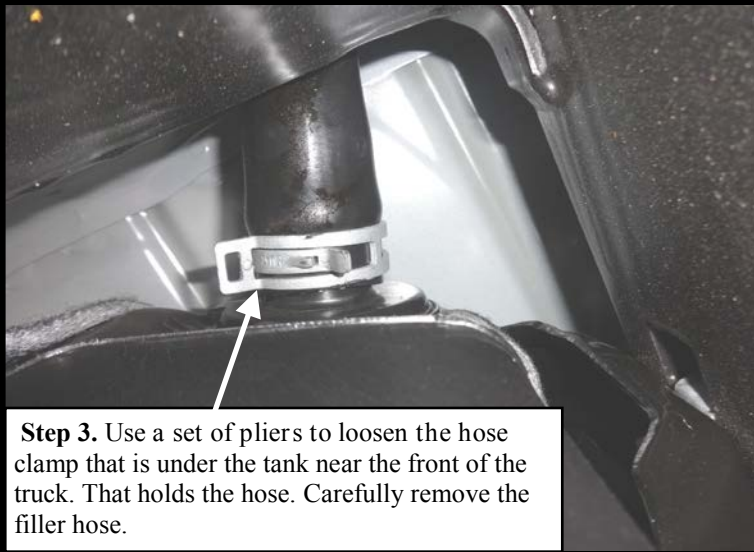

Step 3. Use a set of pliers to loosen the hose clamp that is under the tank near the front of the truck. That holds the hose. Carefully remove the filler hose.

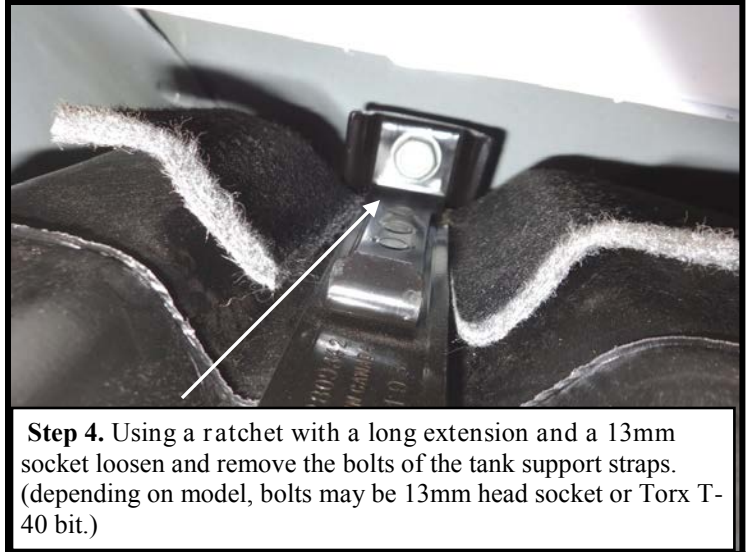

Step 4. Using a ratchet with a long extension and a 13mm socket loosen and remove the bolts of the tank support straps. (depending on model, bolts may be 13mm head socket or Torx T-40 bit.)

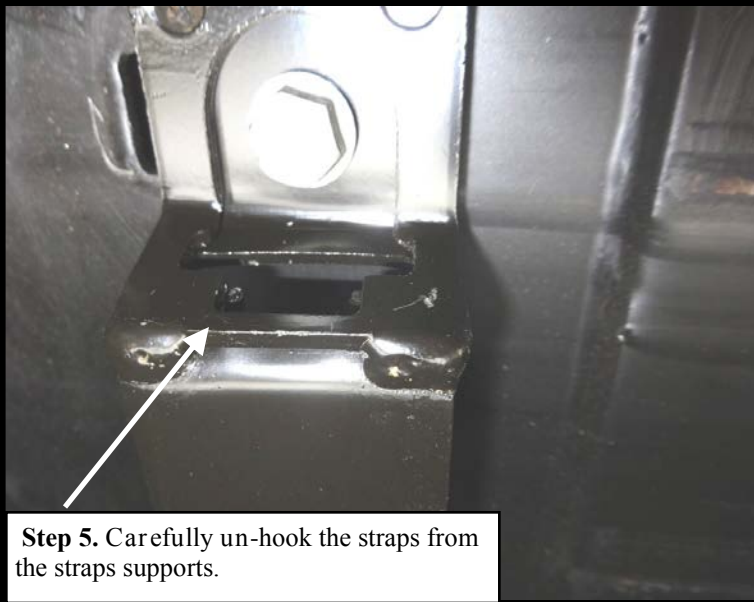

Step 5. Carefully un-hook the straps from the straps supports.

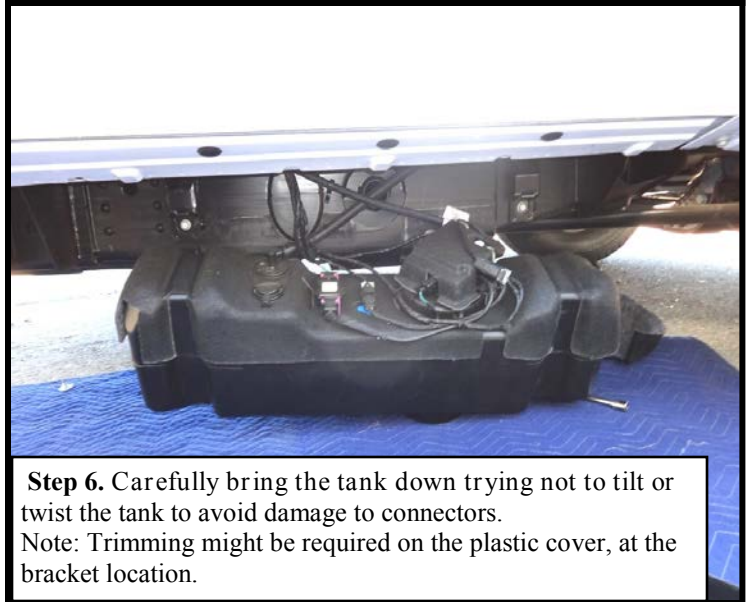

Step 6. Carefully bring the tank down trying not to tilt or twist the tank to avoid damage to connectors. Note: Trimming might be required on the plastic cover, at the bracket location.

INSTALLATION COMPLETE



Sierra 2500 Crew Cab Shown

CARE INSTRUCTIONS

- REGULAR WAXING IS RECOMMENDED. DO NOT USE ANY TYPE OF POLISH OR WAX THAT MAY CONTAIN ABRASIVES.
- STAINLESS STEEL PRODUCTS CAN BE CLEANED WITH MILD SOAP AND WATER. STAINLESS STEEL POLISH SHOULD BE USED TO POLISH SMALL SCRATCHES.
- GLOSS BLACK FINISHES SHOULD BE CLEANED WITH MILD SOAP AND WATER



WARNING



Failure to follow these instructions could lead to death, personal injury, and / or property damage.

Failure to follow these instructions could lead to death, personal injury, and / or property damage.

FASTENERS:

All Westin supplied fasteners must be utilized and installed in accordance with the installation instructions and apply torque to the specifications as defined. **DOUBLE CHECK ALL FASTENERS BEFORE INITIAL USE, AND PERIODICALLY IN THE FUTURE TO ENSURE PROPER FUNCTION AND SAFETY.**

DRILLING:

Most Westin products do not require drilling for installation. If drilling is defined as required, use caution when drilling a vehicle. **FAILURE TO REVIEW AN AREA TO BE DRILLED MAY RESULT IN PERSONAL INJURY AND/OR INJURY TO OTHERS AS WELL AS VEHICLE DAMAGE.**

EYE PROTECTION:

ALWAYS WEAR SAFETY GLASSES OR GOGGLES DURING THE INSTALLATION PROCESS TO AVOID PERSONAL INJURY.

MAXIMUM TOWING/CARRYING CAPACITY: (if applicable)

The Westin Receiver Hitches will have a visible tow rating label affixed directly on the product. User should never exceed the vehicle manufacturers maximum tow and weight rating regardless of the capacity of the hitch. **FAILURE TO FOLLOW THESE GUIDELINES WILL VOID THE WESTIN WARRANTY AND MAY RESULT IN PERSONAL INJURY AND/OR INJURY TO OTHERS AS WELL AS VEHICLE DAMAGE.**



Learn more about running boards and step bars we have.