

INSTALLATION INSTRUCTIONS

PRO SERIES REAR BUMPER



APPLICATION:

Chevrolet Silverado/ Sierra 1500 2019-2020
(Excl. 2019 Silverado LD/Limited); 2500/3500 2020

PART NUMBER:

58-421215

CONTENT			
ITEM	QUANTITY	DESCRIPTION	TOOLS NEEDED
1	1	REAR BUMPER	10MM SOCKET
2	1	DRIVER MAIN BRACKET	10MM WRENCH
3	1	PASSENGER MAIN BRACKET	19MM SOCKET
4	1,1	MONITOR MOUNTING PLATE DVR, PASS	19MM WRENCH
5	1	DRIVER MONITOR BRACE	RATCHET
6	1	PASSENGER MONITOR BRACE	TORQUE WRENCH
7	1	DRIVER EXHAUST TIP BRACKET	ALLEN
8	1	PASSENGER EXHAUST TIP BRACKET	13MM SOCKET
9	4	SENSOR L-TAB	13MM WRENCH
10	4	SENSOR HOLE PLUG	
11	10	M12 SPLIT LOCK WASHER (YELLOW ZINC)	
12	10	M12 SERRATED FLANGE BOLT (YELLOW ZINC)	
13	20	M12 FLAT WASHER (YELLOW ZINC)	
14	10	M12 HEX NUT (YELLOW ZINC)	
15	4	M6 FLAT WASHER (YELLOW ZINC)	
16	4	M6 HEX NUT (YELLOW ZINC)	
17	4	M6 CARRIAGE BOLT (YELLOW ZINC)	
18	4	M6 SPLIT LOCK WASHER (YELLOW ZINC)	
19	2	M8 HEX HEAD BOLT (YELLOW ZINC)	
20	4	M8 FLAT WASHER (YELLOW ZINC)	
21	2	M8 SPLIT LOCK WASHER (YELLOW ZINC)	
22	2	M8 HEX NUT (YELLOW ZINC)	
23	6	M6 BUTTON HEAD BOLT (BLACK ZINC)	
24	6	M6 SERRATED FLANGE NUT (BLACK ZINC)	
25	6	M6 FLAT WASHER (BLACK ZINC)	
26	12	M5 BUTTON HEAD BOLT (BLACK ZINC)	
27	12	M5 SERRATED FLANGE NUT (BLACK ZINC)	
28	12	M5 FLAT WASHER (BLACK ZINC)	

ANTI-SEIZE LUBRICANT MUST BE USED ON ALL STAINLESS STEEL FASTENERS TO PREVENT THREAD DAMAGE AND GALLING



ITEM 1

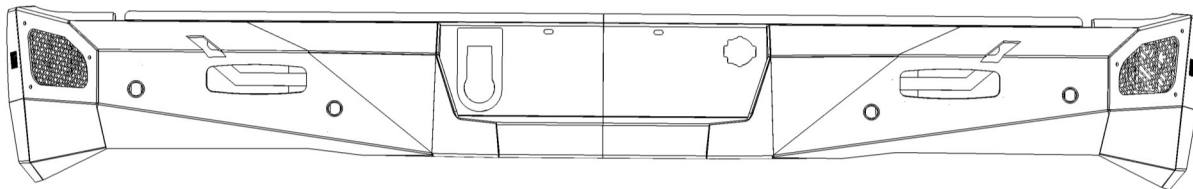

ITEM 2

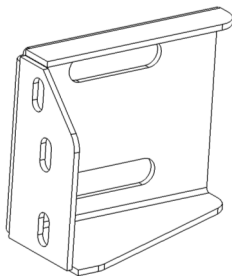

ITEM 4

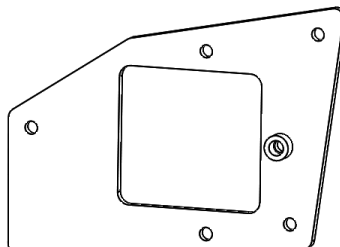

ITEM 7

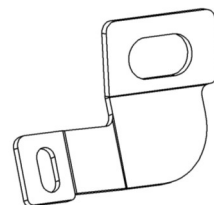

DVR SHOWN

ITEM 9

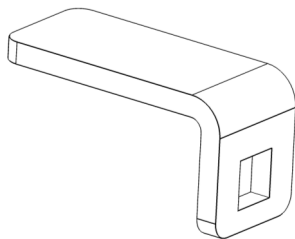

ITEM 10

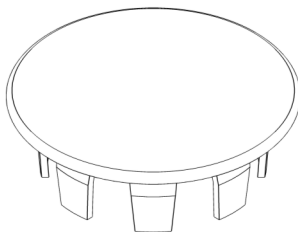

ITEM 5



PROCEDURE

1. Remove contents from box, verify if all parts listed are present and free from damage.
Carefully read and understand all instructions before attempting installation.
Failure to identify damage before installation could lead to a rejection of any claim.

2. Remove tubular supports on sides of bumper.
3. Remove all electrical connections from the rear bumper.
4. Remove the two nuts and two bolts on each side of the rear bumper. **See Figure 1-2**
5. Remove the rear bumper.

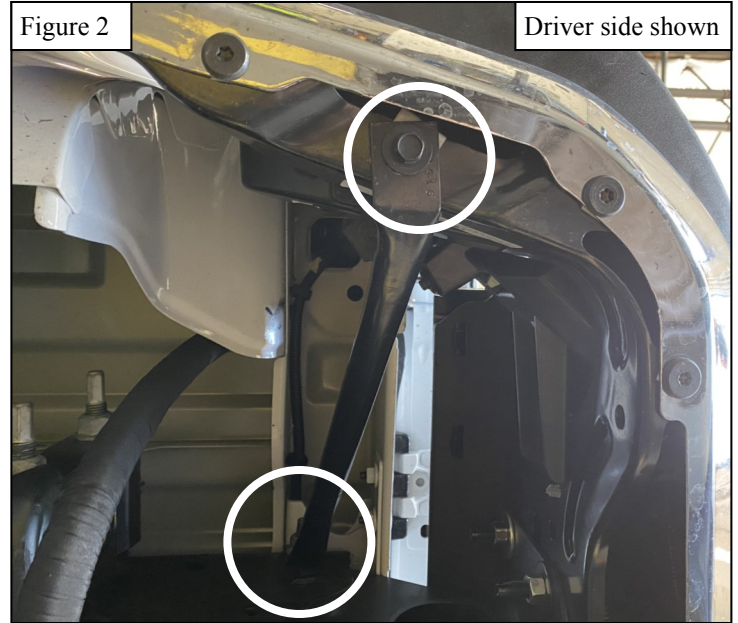
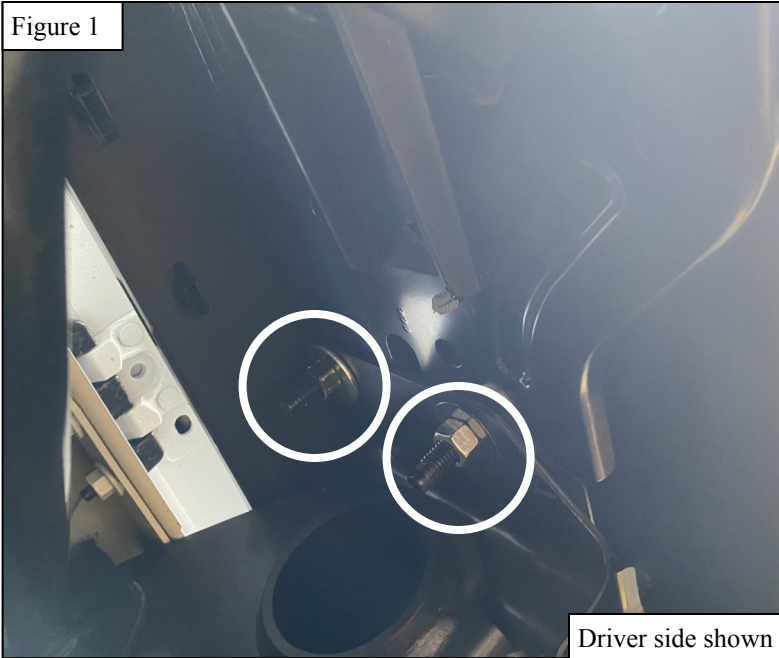

6. Install parking sensors by inserting into the holes on bumper and pressing with sensor L-tabs against bumper plate. Fasten L-tabs with the supplied M6 hardware (15-18). **See Figure 3-5.**
Note: Be sure to maintain the orientation of the sensor so that it remains consistent with its original orientation.
7. Tighten M6 hardware to 5-7 ft-lbs. *Note: if sensors are not equipped, install the supplied sensor plugs into the holes.*

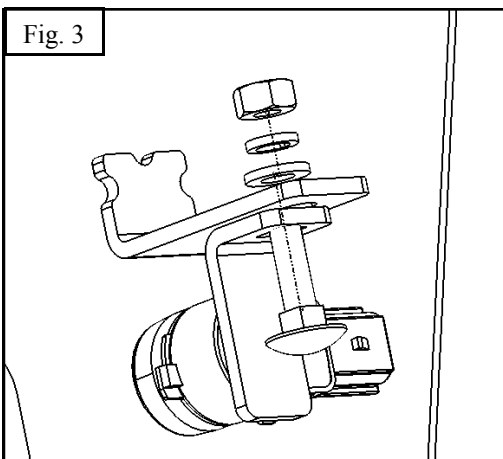

Make sure to maintain
OEM orientation of
sensors



Fig. 5

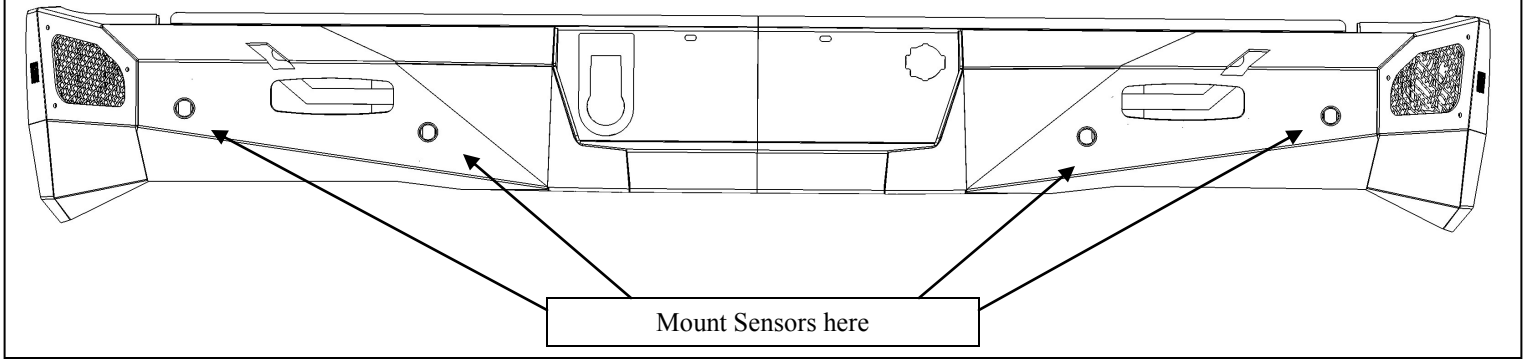

8. **If blind spot monitor is equipped**– Remove the blind spot monitor from the OE bumper and using items 4 and 5 mount monitor as shown on Fig. 6 and 7.
9. **If blind spot monitor is not equipped**- Leave cover attached on bumper and proceed to the next step.

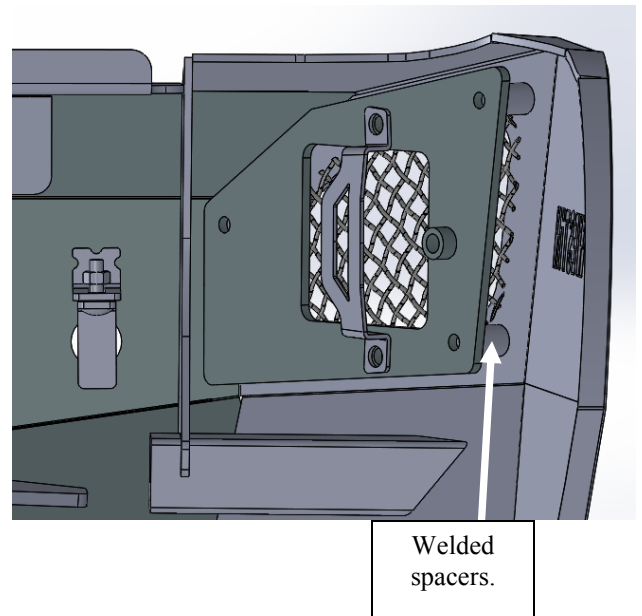
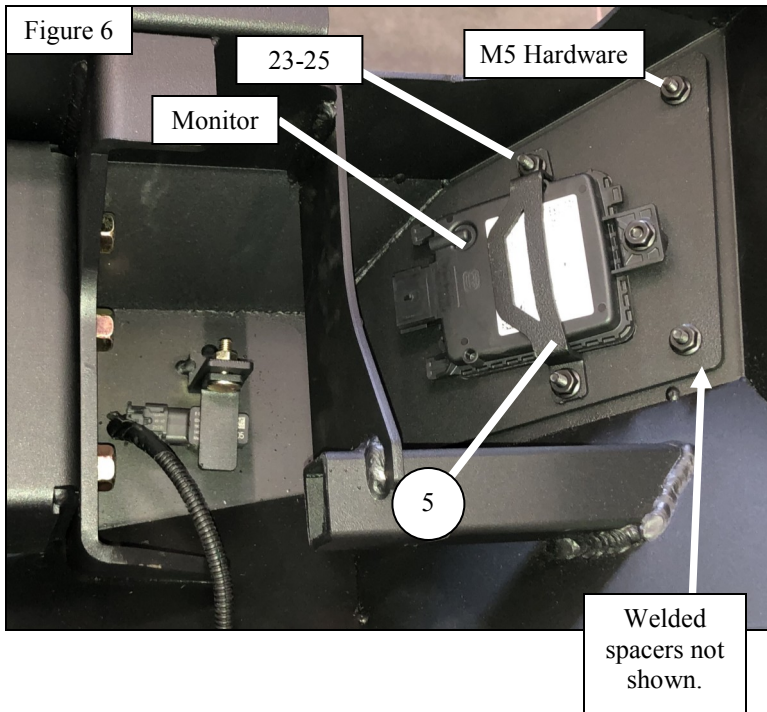

9. Using the supplied M12 hardware, loosely install bumper brackets on to the bumper. Then loosely assemble the bumper to the frame brackets. See Figure 7.

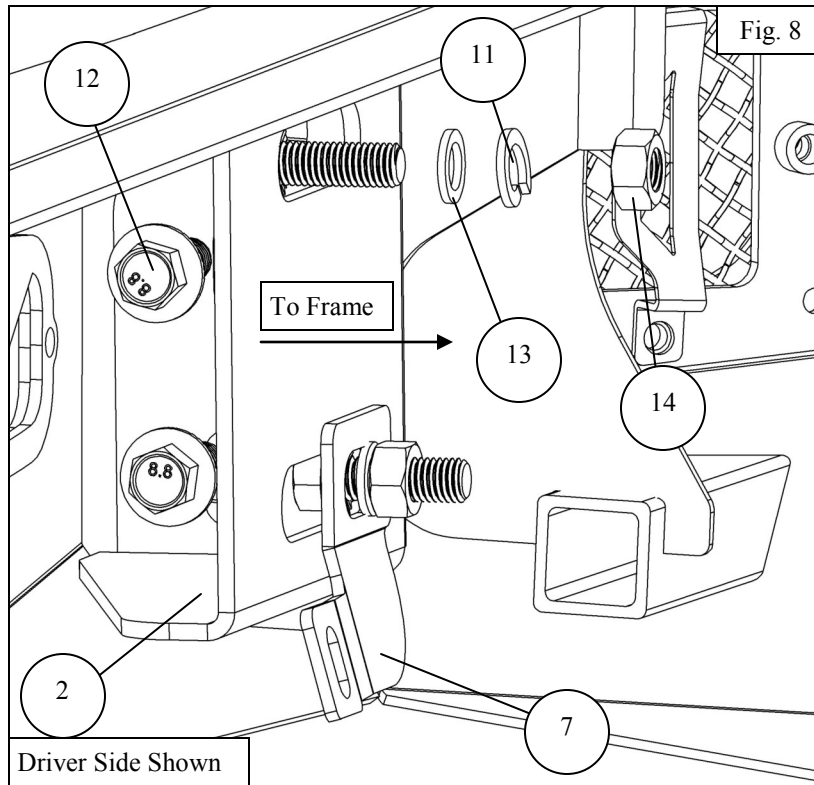

9. Install the Trailer plug and license plate at this time.

WARNING .

After you have mounted bumper on main brackets. CAREFULLY open tailgate. While tailgate is open, adjust the height of the bumper so that it has about 3/8" of clearance with respect to the tailgate. Torque to 50-55 ft-lbs.

INSTALLATION COMPLETE



CARE INSTRUCTIONS

- REGULAR WAXING IS RECOMMENDED. DO NOT USE ANY TYPE OF POLISH OR WAX THAT MAY CONTAIN ABRASIVES.
- STAINLESS STEEL PRODUCTS CAN BE CLEANED WITH MILD SOAP AND WATER. STAINLESS STEEL POLISH SHOULD BE USED TO POLISH SMALL SCRATCHES.
- GLOSS BLACK FINISHES SHOULD BE CLEANED WITH MILD SOAP AND WATER.

WESTIN



WARNING



Failure to follow these instructions could lead to death, personal injury, and / or property damage.

Failure to follow these instructions could lead to death, personal injury, and / or property damage.

FASTENERS:

All Westin supplied fasteners must be utilized and installed in accordance with the installation instructions and apply torque to the specifications as defined. **DOUBLE CHECK ALL FASTENERS BEFORE INITIAL USE, AND PERIODICALLY IN THE FUTURE TO ENSURE PROPER FUNCTION AND SAFETY.**

DRILLING:

Most Westin products do not require drilling for installation. If drilling is defined as required, use caution when drilling a vehicle. **FAILURE TO REVIEW AN AREA TO BE DRILLED MAY RESULT IN PERSONAL INJURY AND/OR INJURY TO OTHERS AS WELL AS VEHICLE DAMAGE.**

EYE PROTECTION:

ALWAYS WEAR SAFETY GLASSES OR GOGGLES DURING THE INSTALLATION PROCESS TO AVOID PERSONAL INJURY.

MAXIMUM TOWING/CARRYING CAPACITY: (if applicable)

The Westin Receiver Hitches will have a visible tow rating label affixed directly on the product. User should never exceed the vehicle manufacturers maximum tow and weight rating regardless of the capacity of the hitch. **FAILURE TO FOLLOW THESE GUIDELINES WILL VOID THE WESTIN WARRANTY AND MAY RESULT IN PERSONAL INJURY AND/OR INJURY TO OTHERS AS WELL AS VEHICLE DAMAGE.**

FOR CALIFORNIA RESIDENTS ONLY-PROP 65 WARNING:

Some products may contain chemicals such as DEHP, which can cause cancer, birth defects or other reproductive harm.



Learn more about off-road bumpers we have.