

INSTALLATION INSTRUCTIONS

PRO-SERIES REAR BUMPER



APPLICATION:
2011-2016 Ford F-250/350/450/550 Super Duty
PART NUMBER:
58-421205

CONTENT			
ITEM	QUANTITY	DESCRIPTION	TOOLS NEEDED
1	1	REAR BUMPER	10MM SOCKET
2	1	DRIVER MAIN BRACKET	10MM WRENCH
3	1	PASSENGER MAIN BRACKET	19MM SOCKET
4	1	DRIVER FRAME BRACKET	19MM WRENCH
5	1	PASSENGER FRAME BRACKET	TRIM TOOL
6	4	L-TAB SENSOR	RATCHET
7	4	SENSOR PLUG	TORQUE WRENCH
8	18	M12 SPLIT LOCK WASHER (YELLOW ZINC)	
9	18	M12 SERRATED FLANGE BOLT (YELLOW ZINC)	
10	36	M12 FLAT WASHER (YELLOW ZINC)	
11	18	M12 HEX NUT (YELLOW ZINC)	
12	4	M6 FLAT WASHER (YELLOW ZINC)	
13	4	M6 HEX NUT (YELLOW ZINC)	
14	4	M6 CARRIAGE BOLT (YELLOW ZINC)	
15	4	M6 SPLIT LOCK WASHER (YELLOW ZINC)	
16	6	M6 BUTTON HEAD BOLT (BLACK ZINC)	
17	6	M6 SERRATED FLANGE NUT (BLACK ZINC)	
18	6	M6 FLAT WASHER (BLACK ZINC)	

ANTI-SEIZE LUBRICANT MUST BE USED ON ALL STAINLESS STEEL FASTENERS TO PREVENT THREAD DAMAGE AND GALLING

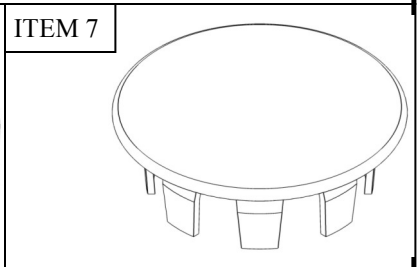
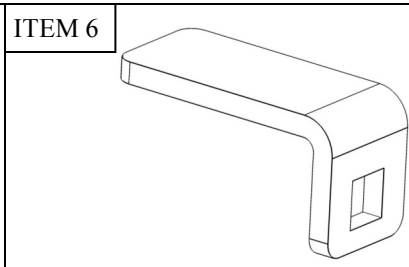
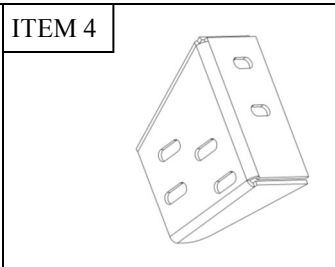
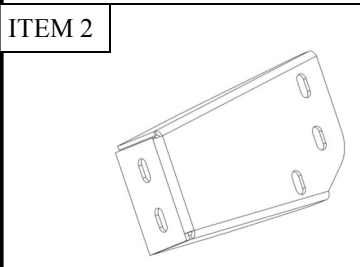
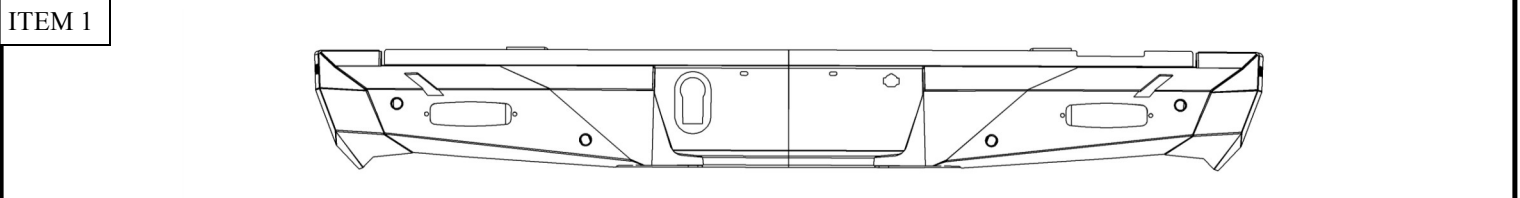

PROCEDURE

1. Remove contents from box, verify if all parts listed are present and free from damage.
Carefully read and understand all instructions before attempting installation.
Failure to identify damage before installation could lead to a rejection of any claim.

2. Remove all electrical connections (plugs wires, etc.) from the rear bumper.
3. Unbolt the two nuts from the frame holding the bumper brackets on each side of the vehicle. Slide the bumper off. **See Figure 1**

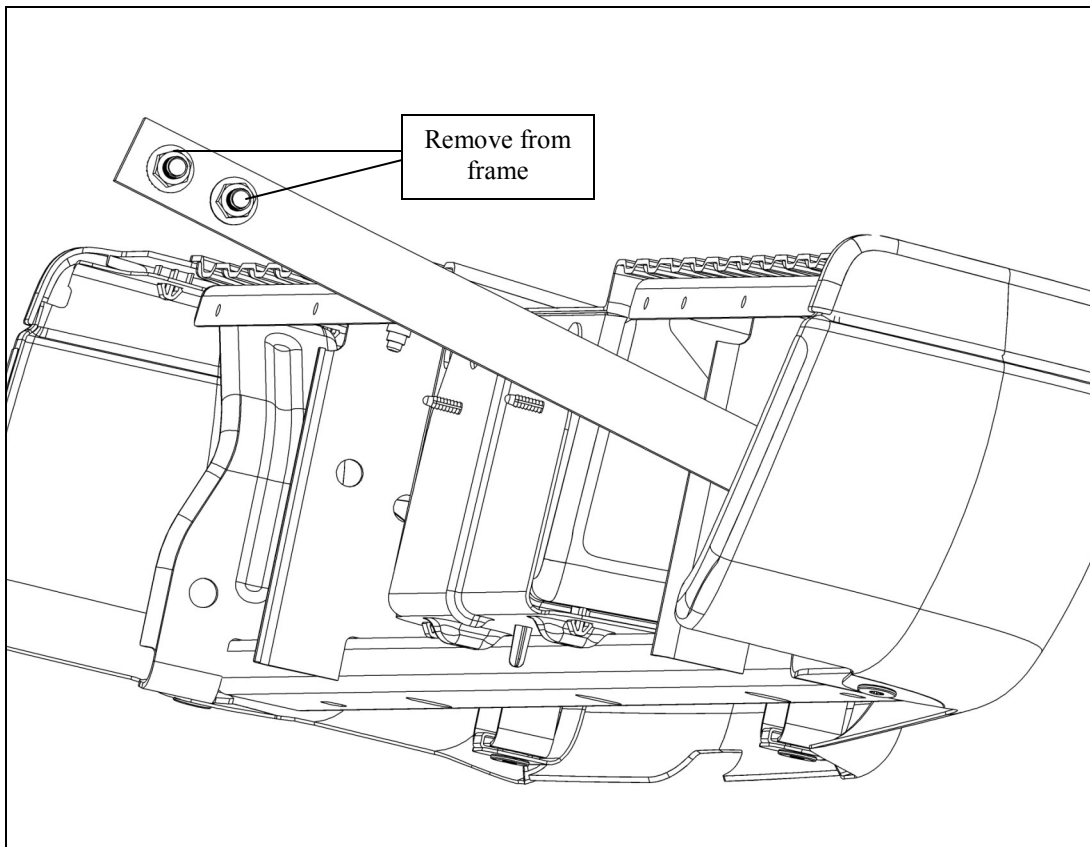

4. Install parking sensors by inserting into the holes on bumper and pressing with sensor L-tabs against bumper plate. Fasten L-tabs with the supplied M6 hardware (12-15). **See Figure 2-4.**
Note: Be sure to maintain the orientation of the sensor so that it remains consistent with its original orientation.
5. Tighten M6 hardware to 5-7 ft-lbs. *Note: if sensors are not equipped, install the supplied sensor plugs into the holes.*

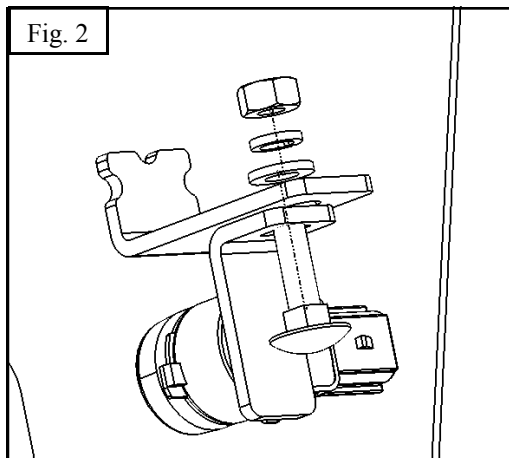

Make sure to maintain
OEM orientation of
sensors

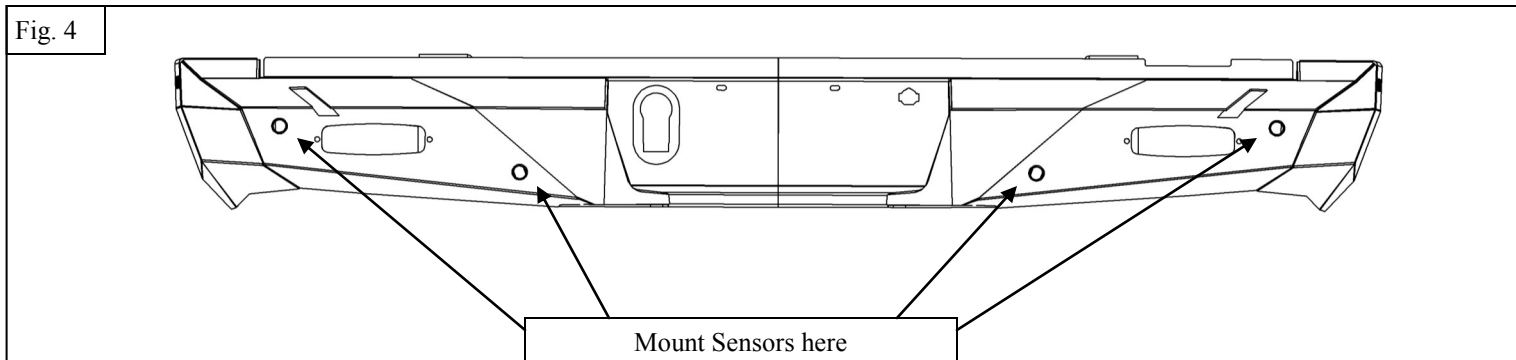

6. Loosely assemble the main brackets to the bumper using supplied M12 Hardware. See **Figure 5**.

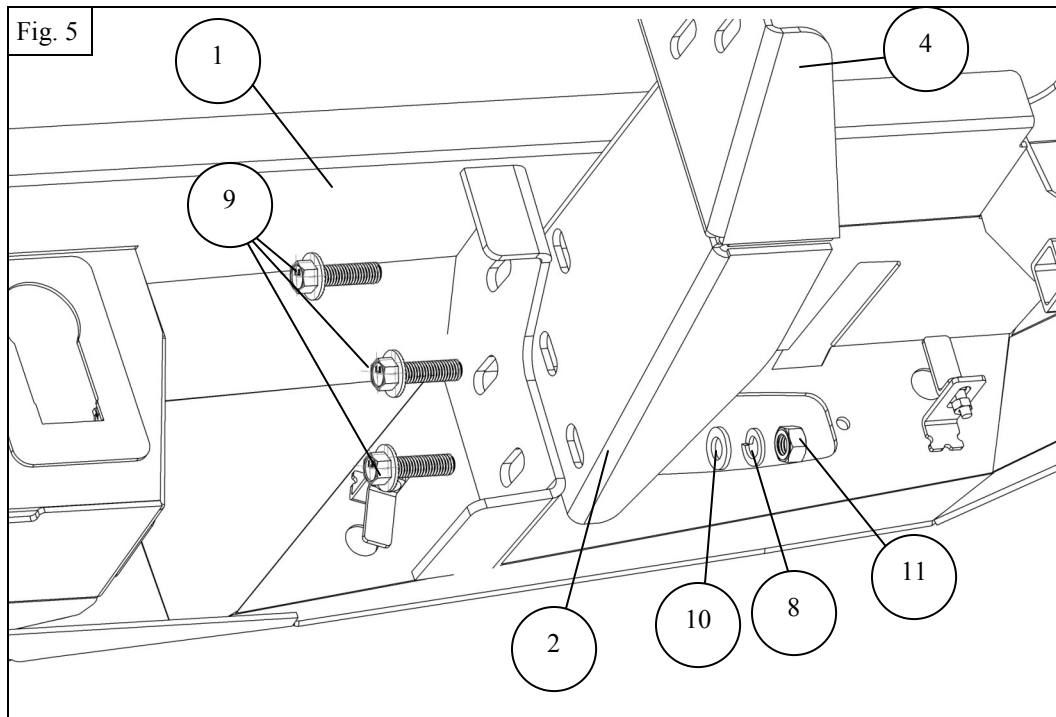

7. Loosely assemble the frame brackets to the frame using the supplied M12 hardware. *Note: Insert the bolt through the inside of the frame.* See **Figure 6**.

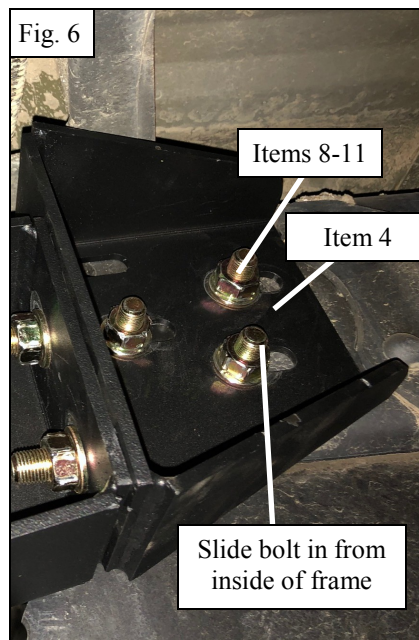

8. With help, loosely assemble the bumper assembly to the frame brackets using the supplied M12 Hardware. See **Figure 7**.

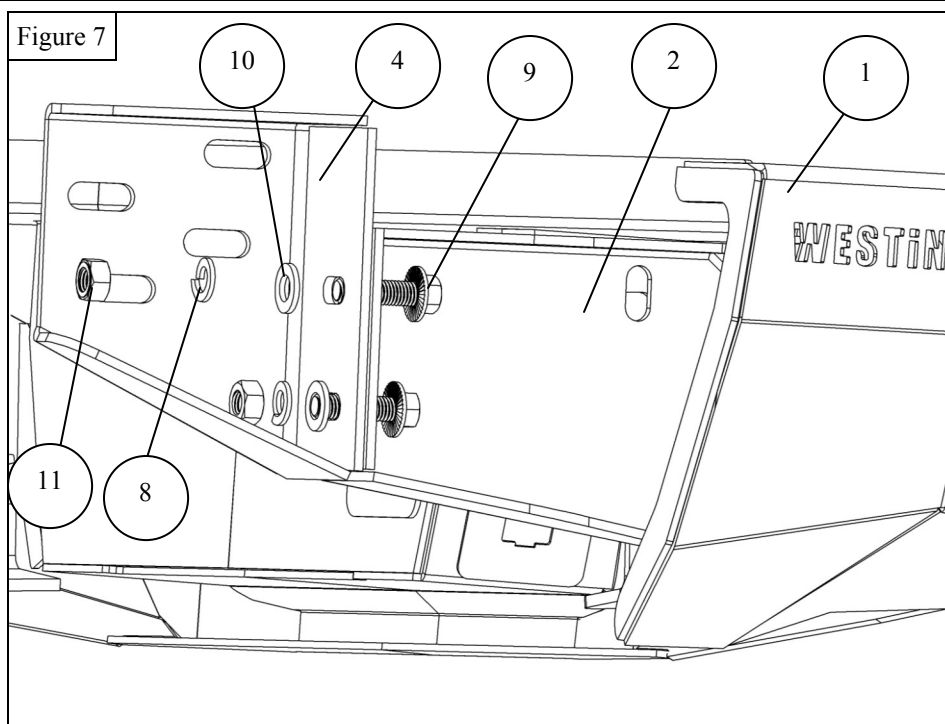

9. Install the Trailer plug and license plate, and accessory lights at this time (Black M6 hardware is provided).

WARNING .

After you have mounted bumper on main brackets. CAREFULLY open tailgate. While tailgate is open, adjust the height of the bumper so that it has about 3/8" of clearance with respect to the tailgate. Torque to 50-55 ft-lbs.

INSTALLATION COMPLETED



CARE INSTRUCTIONS

- REGULAR WAXING IS RECOMMENDED. DO NOT USE ANY TYPE OF POLISH OR WAX THAT MAY CONTAIN ABRASIVES.
- STAINLESS STEEL PRODUCTS CAN BE CLEANED WITH MILD SOAP AND WATER. STAINLESS STEEL POLISH SHOULD BE USED TO POLISH SMALL SCRATCHES.
- GLOSS BLACK FINISHES SHOULD BE CLEANED WITH MILD SOAP AND WATER.

WESTiN



WARNING



Failure to follow these instructions could lead to death, personal injury, and / or property damage.

Failure to follow these instructions could lead to death, personal injury, and / or property damage.

FASTENERS:

All Westin supplied fasteners must be utilized and installed in accordance with the installation instructions and apply torque to the specifications as defined. **DOUBLE CHECK ALL FASTENERS BEFORE INITIAL USE, AND PERIODICALLY IN THE FUTURE TO ENSURE PROPER FUNCTION AND SAFETY.**

DRILLING:

Most Westin products do not require drilling for installation. If drilling is defined as required, use caution when drilling a vehicle. **FAILURE TO REVIEW AN AREA TO BE DRILLED MAY RESULT IN PERSONAL INJURY AND/OR INJURY TO OTHERS AS WELL AS VEHICLE DAMAGE.**

EYE PROTECTION:

ALWAYS WEAR SAFETY GLASSES OR GOGGLES DURING THE INSTALLATION PROCESS TO AVOID PERSONAL INJURY.

MAXIMUM TOWING/CARRYING CAPACITY: (if applicable)

The Westin Receiver Hitches will have a visible tow rating label affixed directly on the product. User should never exceed the vehicle manufacturers maximum tow and weight rating regardless of the capacity of the hitch. **FAILURE TO FOLLOW THESE GUIDELINES WILL VOID THE WESTIN WARRANTY AND MAY RESULT IN PERSONAL INJURY AND/OR INJURY TO OTHERS AS WELL AS VEHICLE DAMAGE.**

FOR CALIFORNIA RESIDENTS ONLY-PROP 65 WARNING:

Some products may contain chemicals such as DEHP, which can cause cancer, birth defects or other reproductive harm.



Learn more about off-road bumpers we have.