

# INSTALLATION INSTRUCTIONS

## PROMOD FRONT BUMPER



**APPLICATION:**  
2011-2016 Ford F-250/350/450/550 Super Duty  
**PART NUMBER:**  
58-41205

<b>CONTENT</b>			
<b>ITEM</b>	<b>QUANTITY</b>	<b>DESCRIPTION</b>	<b>TOOLS NEEDED</b>
1	2	SIDE POD ASSEMBLY (1 DRIVER, 1 PASSENGER)	4MM ALLEN
2	2	MESH SIDE COVERS (1 DRIVER, 1 PASSENGER)	10MM WRENCH
3	1	CENTER SECTION	13MM SOCKET
4	2	LED LIGHT BRACKET	13MM WRENCH
5	1	DRIVER MOUNTING BRACKET	17MM SOCKET
6	1	PASSENGER MOUNTING BRACKET	17MM WRENCH
7	1	UPPER PASSENGER SUPPORT BRACKET	19MM SOCKET
8	1	UPPER DRIVER SUPPORT BRACKET	19MM WRENCH
9	1	DRIVER SIDE STRAP	RATCHET
10	1	PASSENGER SIDE STRAP	TORQUE WRENCH
11	1	LOWER DRIVER SUPPORT BRACKET	5MM ALLEN
12	1	LOWER PASSENGER SUPPORT BRACKET	
13	12	M6 BUTTON HEAD BOLT (BLACK ZINC)	
14	12	M6 FLAT WASHER (BLACK ZINC)	
15	12	M6 SERRATED FLANGE NUT (BLACK ZINC)	
16	12	M6 LOCK WASHER (BLACK ZINC)	
17	2	M10 HEX HEAD BOLT (BLACK ZINC)	
18	2	M10 SPLIT LOCK WASHER (BLACK ZINC)	
19	2	M10 FLAT WASHER (BLACK ZINC)	
20	2	M10 HEX NUT (BLACK ZINC)	
21	6	M8 BUTTON HEAD BOLT (BLACK ZINC)	
22	6	M8 SPLIT LOCK WASHER (BLACK ZINC)	
23	12	M8 FLAT WASHERS (BLACK ZINC)	
24	6	M8 HEX NUT (BLACK ZINC)	
25	16	M12 SERRATED FLANGE NUT (YELLOW ZINC)	
26	12	M12 HEX BOLT (YELLOW ZINC)	
27	16	M12 SPLIT LOCK WASHER (YELLOW ZINC)	
28	28	M12 FLAT WASHER (YELLOW ZINC)	

**ANTI-SEIZE LUBRICANT MUST BE USED ON ALL STAINLESS STEEL FASTENERS TO PREVENT THREAD DAMAGE AND GALLING**



29	4	M10 HEX HEAD BOLT (YELLOW ZINC)	
30	4	M10 SPLIT LOCK WASHER (YELLOW ZINC)	
31	8	M10 FLAT WASHER (YELLOW ZINC)	
32	4	M10 HEX NUT 8 M10 FLAT WASHER (YELLOW ZINC)	
33	4	M12 NYLOCK NUTS (YELLOW ZINC)	
34	6	M12 SPLIT LOCK WASHER (BLACK ZINC)	
35	6	M12 FLAT WASHER (BLACK ZINC)	
36	2	M12 HEX HEAD BOLT SHORT (BLACK ZINC)	
37	4	M12 HEX HEAD BOLT LONG (BLACK ZINC)	

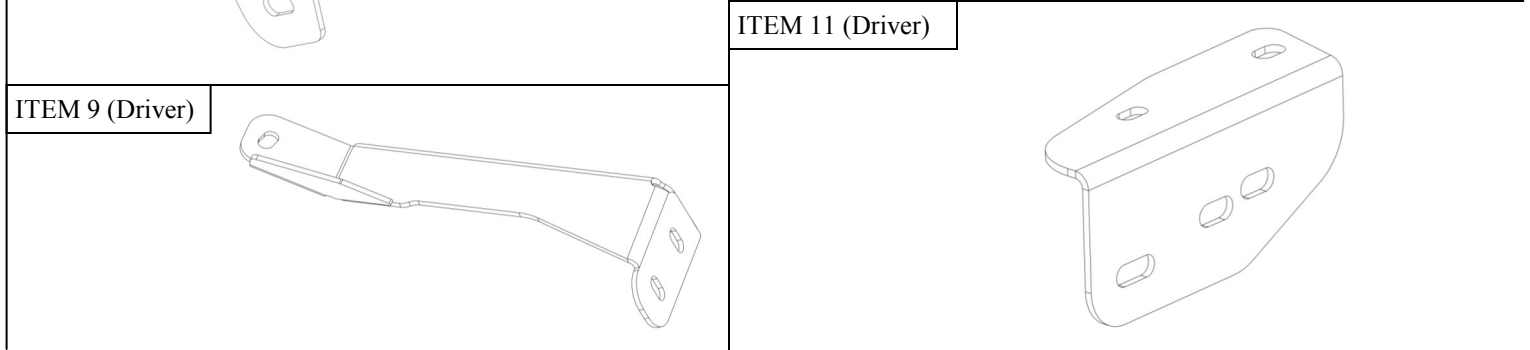
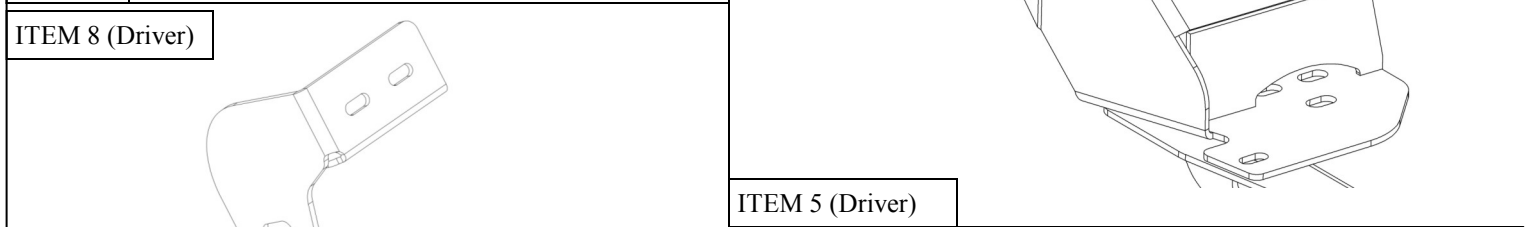
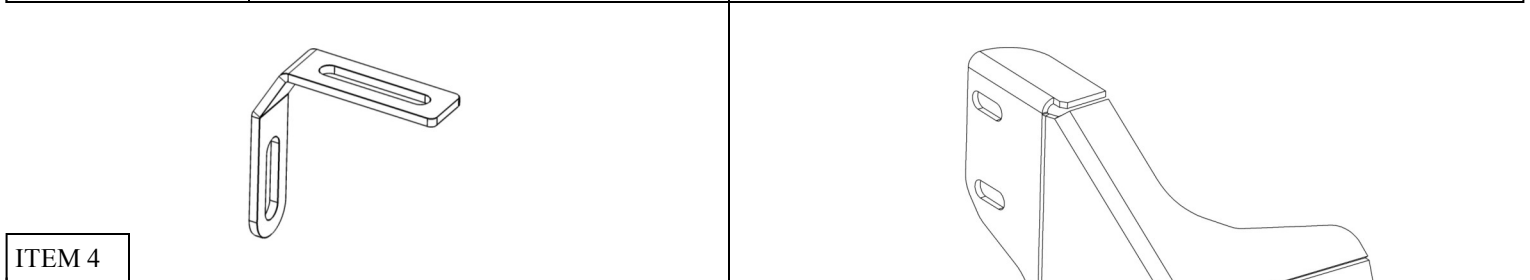
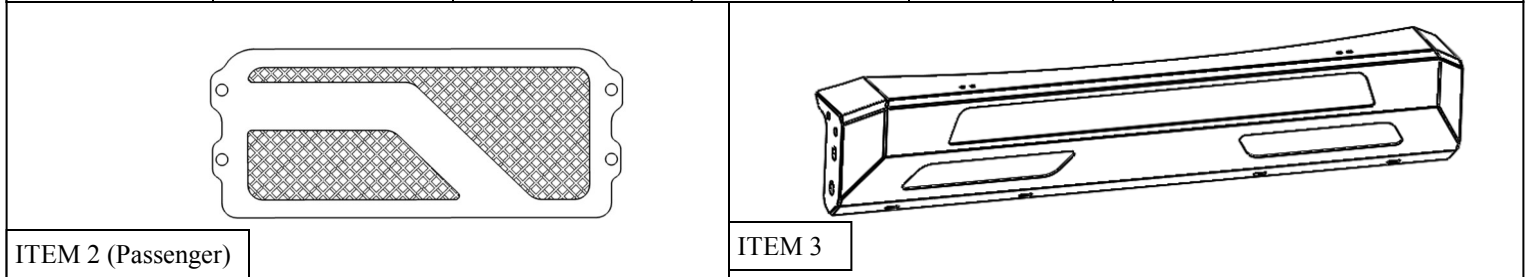
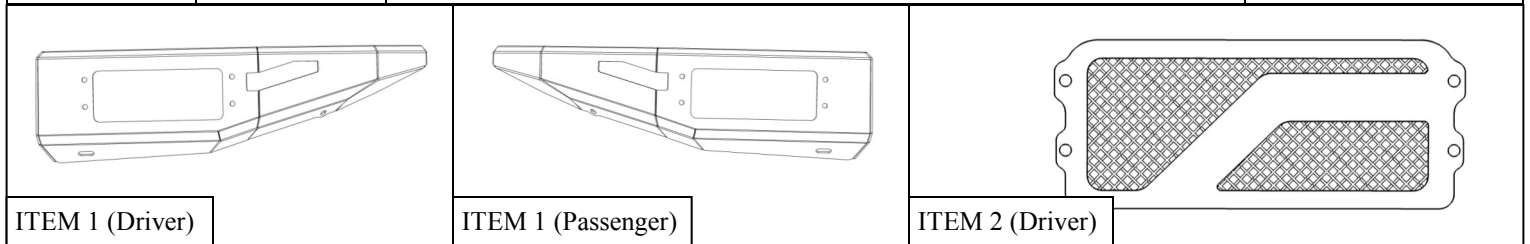

## PROCEDURE

1. Remove contents from box, verify if all parts listed are present and free from damage.  
Carefully read and understand all instructions before attempting installation.  
**Failure to identify damage before installation could lead to a rejection of any claim.**
2. Remove stock bumper.
  - a. Unbolt the plastic tow hook covers from the bumper. See **Figure 1**.
  - b. Disconnect all electrical connections to the bumper.
  - c. Unbolt the bumper from the two factory brackets. See **Figure 2**.
  - d. Remove stock bumper.



3. Unbolt the three bolts holding on the tow hooks. **See Figure 3** *Note: Factory tow hooks cannot be reused with this bumper.*
4. Unbolt the two bolts holding the factory box under the frame. **See Figure 3**



5. Unbolt the two bolts holding on the factory bumper support brackets on each side. **See Figure 4.**



6. Using the supplied M12 Hardware, loosely assemble the main mounting brackets (5, 6). See **Figure 5-6**. Note: All Hardware mounts in a similar way to **Figure 6** unless otherwise specified.

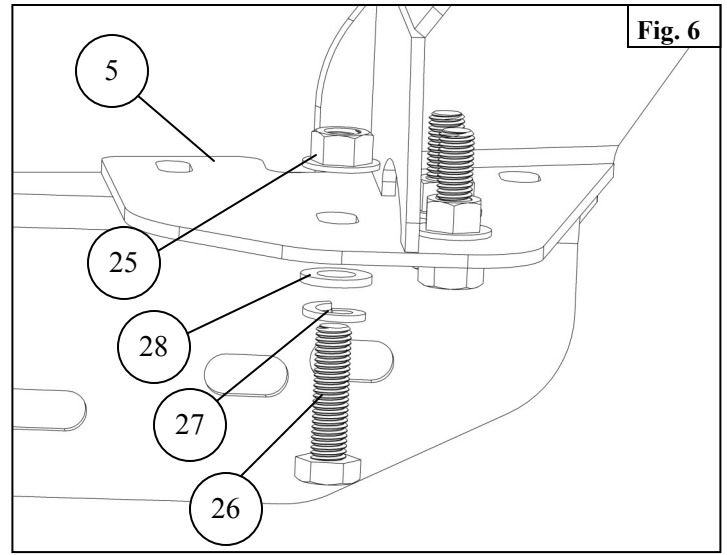
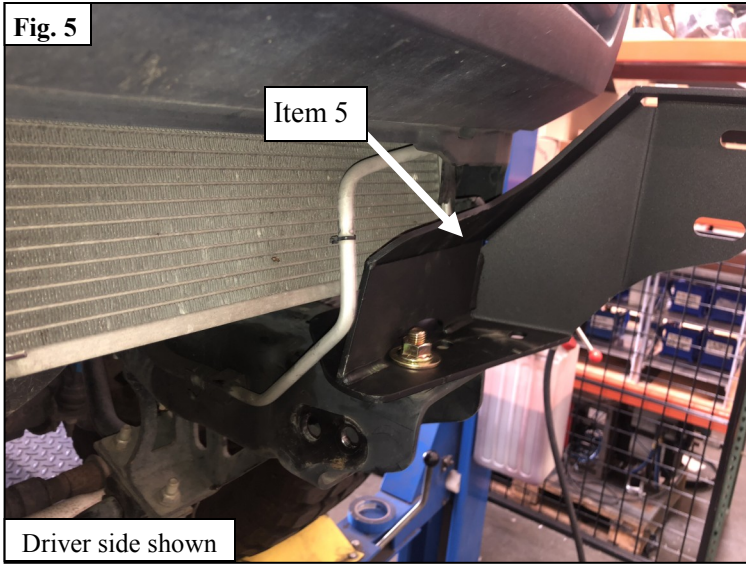

7. Using supplied M10 and M12 Hardware, Install the lower support bracket (11) onto the frame and the main bracket. Item 36 screws into item 25 through frame (not pictured). Note: black zinc and yellow zinc hardware is used simultaneously in this step. Be sure to pay attention to the figure below for part locations. See **Figure 7-9**

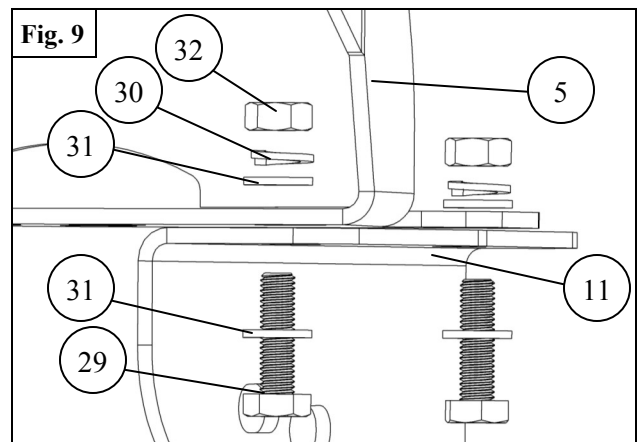
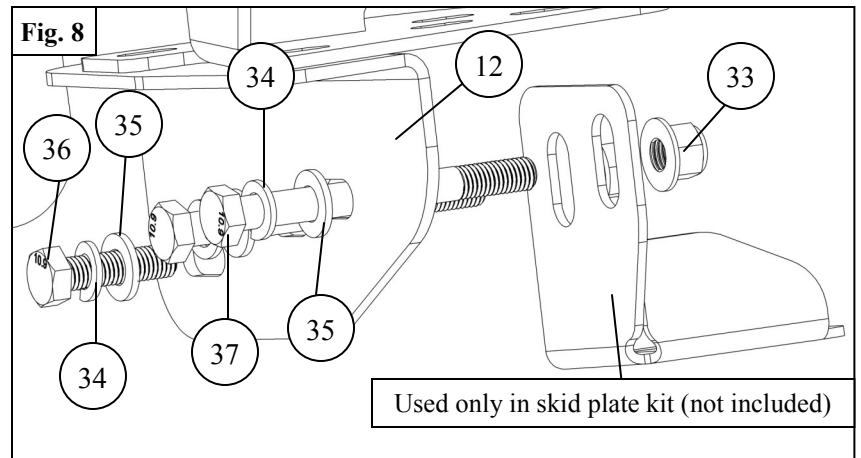
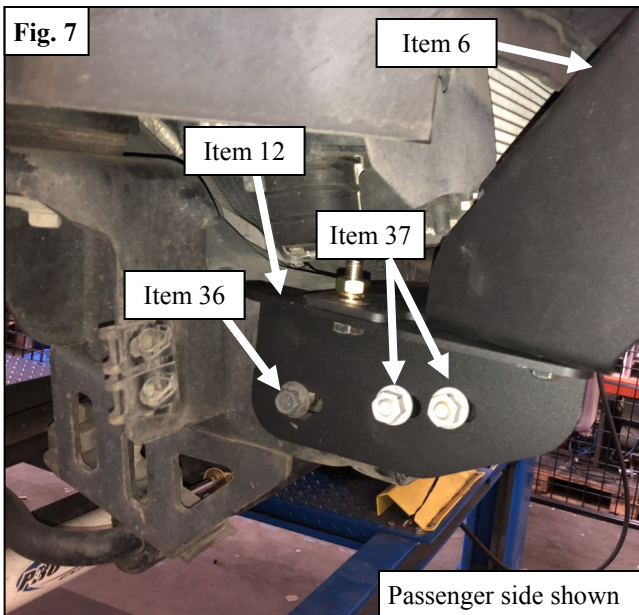

8. Loosely attach the Center Section (3), main support brackets (5,6), and the side pods (1,2) using the supplied M12 Hardware. See **Figure 10**.

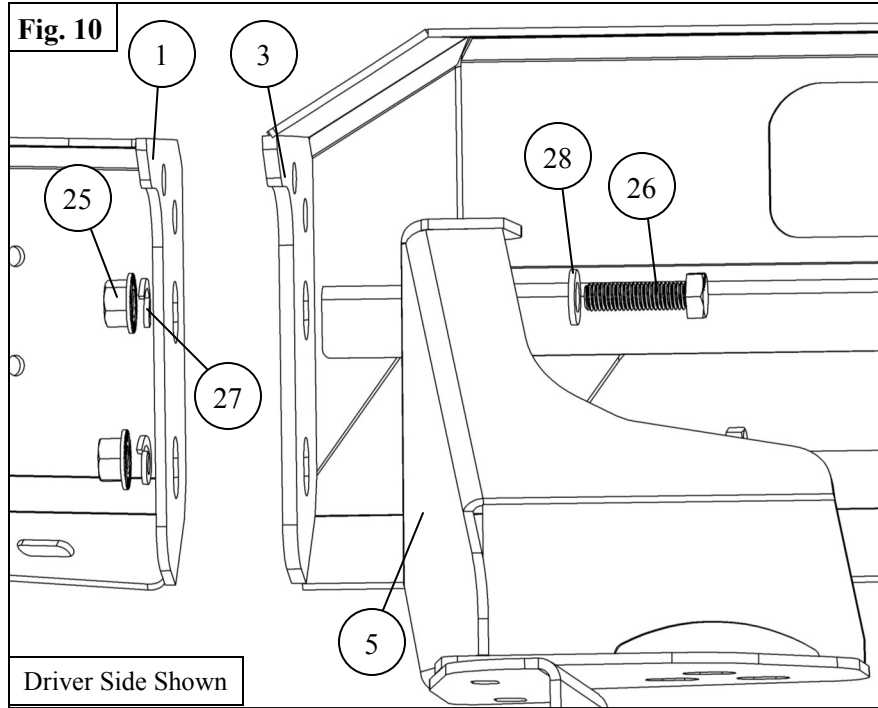

9. Use the supplied M6 Hardware to attach the LED Brackets (4) to the center section. See **Figure 11**. *Note: If installing an LED Light Bar (sold separately), install it at this time.*
10. Loosely install the upper support brackets (7, 8) onto the frame body posts using the supplied M10 black zinc hardware. See **Figure 12**
11. Assemble the upper support straps (9, 10) onto the upper support bracket and the side pods using supplied M8 hardware. See **Figure 13**.

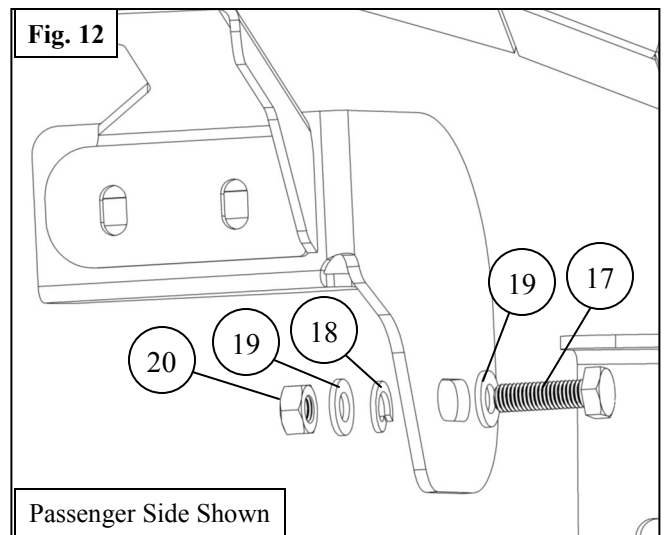
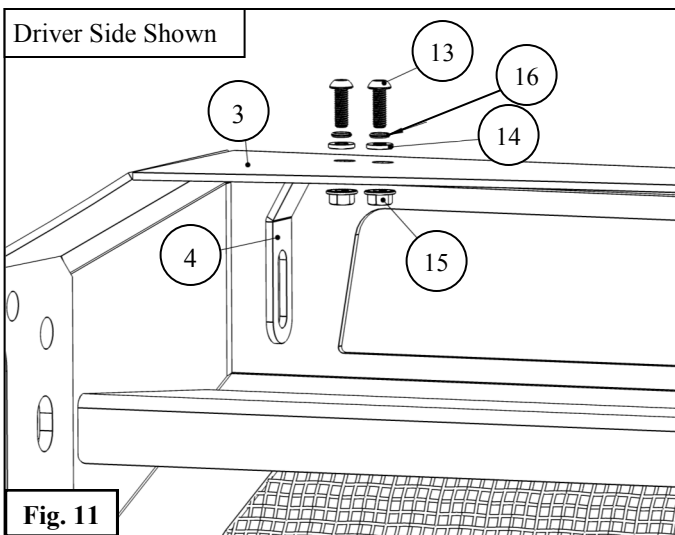

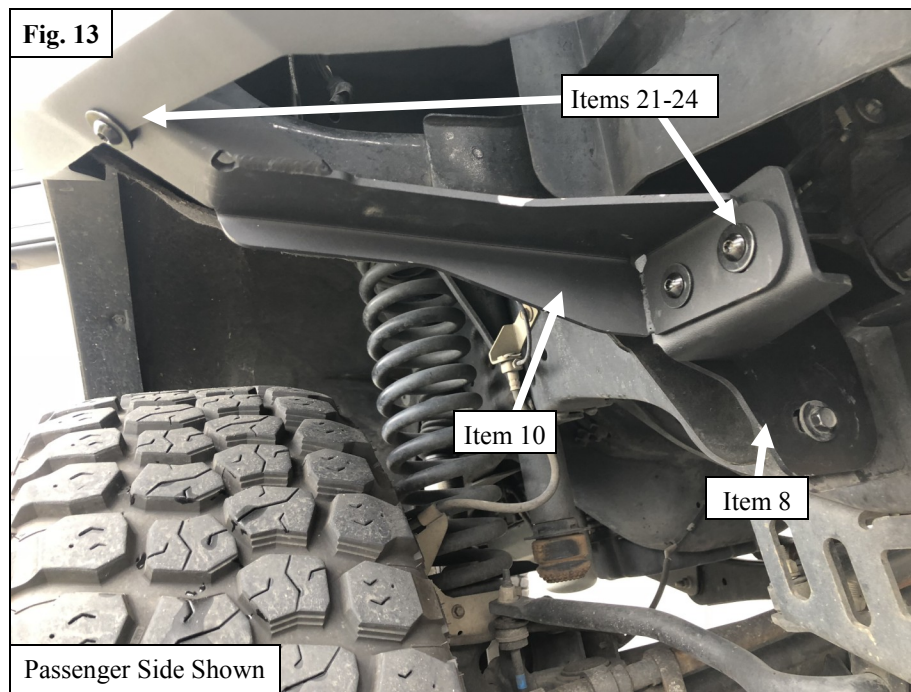

12. Attach the Mesh Side Covers (2) to the Bumper using the supplied M6 Hardware. See **Figures 14 & 15**.

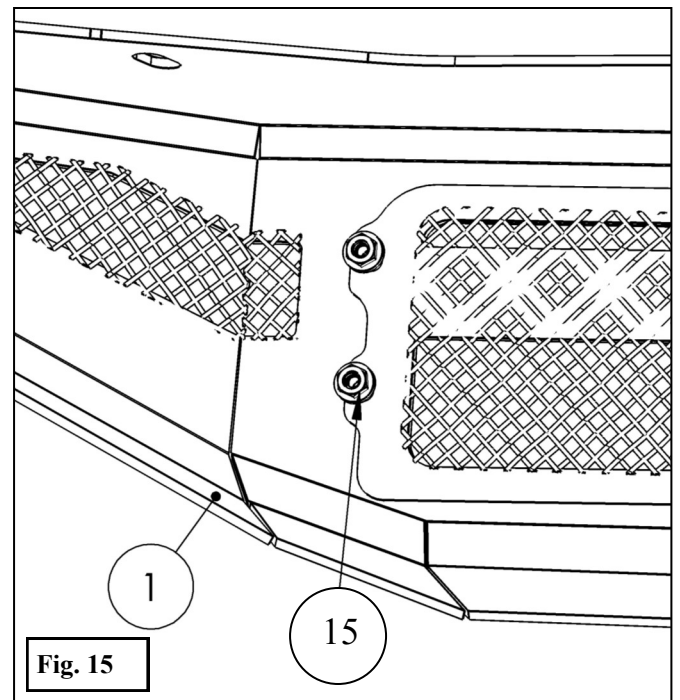
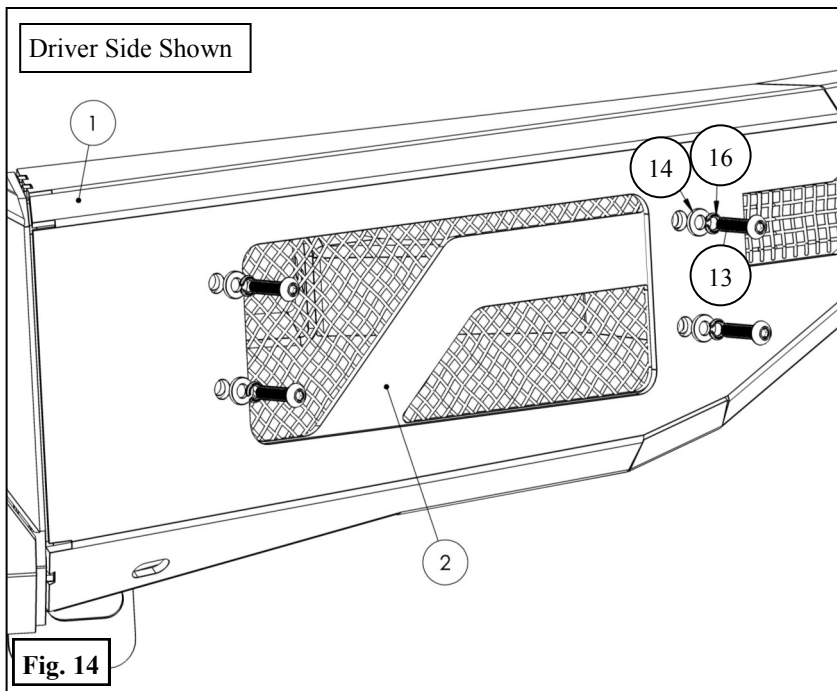

13. Align bumper as desired and torque all hardware as specified: M6 to 7 ft-lbs, M8 to 18 ft-lbs, M10 to 38 ft-lbs, M12 to 60 ft-lbs.

INSTALLATION COMPLETE



©2019 WESTIN AUTOMOTIVE PRODUCTS, INC. ALL RIGHTS RESERVED

LED Lights and skid plate sold separately

#### CARE INSTRUCTIONS

- REGULAR WAXING IS RECOMMENDED. DO NOT USE ANY TYPE OF POLISH OR WAX THAT MAY CONTAIN ABRASIVES.
- STAINLESS STEEL PRODUCTS CAN BE CLEANED WITH MILD SOAP AND WATER. STAINLESS STEEL POLISH SHOULD BE USED TO POLISH SMALL SCRATCHES.
- GLOSS BLACK FINISHES SHOULD BE CLEANED WITH MILD SOAP AND WATER.

**WESTIN**





## WARNING



Failure to follow these instructions could lead to death, personal injury, and / or property damage.

Failure to follow these instructions could lead to death, personal injury, and / or property damage.

### FASTENERS:

All Westin supplied fasteners must be utilized and installed in accordance with the installation instructions and apply torque to the specifications as defined. **DOUBLE CHECK ALL FASTENERS BEFORE INITIAL USE, AND PERIODICALLY IN THE FUTURE TO ENSURE PROPER FUNCTION AND SAFETY.**

### DRILLING:

Most Westin products do not require drilling for installation. If drilling is defined as required, use caution when drilling a vehicle. **FAILURE TO REVIEW AN AREA TO BE DRILLED MAY RESULT IN PERSONAL INJURY AND/OR INJURY TO OTHERS AS WELL AS VEHICLE DAMAGE.**

### EYE PROTECTION:

**ALWAYS WEAR SAFETY GLASSES OR GOGGLES DURING THE INSTALLATION PROCESS TO AVOID PERSONAL INJURY.**

### MAXIMUM TOWING/CARRYING CAPACITY: (if applicable)

The Westin Receiver Hitches will have a visible tow rating label affixed directly on the product. User should never exceed the vehicle manufacturers maximum tow and weight rating regardless of the capacity of the hitch. **FAILURE TO FOLLOW THESE GUIDELINES WILL VOID THE WESTIN WARRANTY AND MAY RESULT IN PERSONAL INJURY AND/OR INJURY TO OTHERS AS WELL AS VEHICLE DAMAGE.**

### FOR CALIFORNIA RESIDENTS ONLY-PROP 65 WARNING:

Some products may contain chemicals such as DEHP, which can cause cancer, birth defects or other reproductive harm.



Learn more about off-road bumpers we have.