

INSTALLATION INSTRUCTIONS

PRO-SERIES FRONT BUMPER

**APPLICATION:**

Chevrolet Silverado 2500/3500 2020

PART NUMBER:

58-411225

CONTENT			
ITEM	QUANTITY	DESCRIPTION	TOOLS NEEDED
1	1	PRO-SERIES FRONT BUMPER	10mm SOCKET
2	1	WINCH TRAY	13mm SOCKET
3	1	MOUNTING BRACKET DRIVER SIDE	18mm SOCKET
4	1	MOUNTING BRACKET PASSENGER SIDE	18mm SOCKET
5	1	WINCH TRAY BRACKET DRIVER SIDE	PRY TOOL
6	1	WINCH TRAY BRACKET PASSENGER SIDE	TORQUE WRENCH
7	1	SHUTTER RELOCATOR BRACKET DRIVER SIDE	RATCHET
8	1	SHUTTER RELOCATOR BRACKET PASSENGER SIDE	
9	2	CENTER SENSOR PLATE	
10	2	OUTTER SENSOR PLATE	
11	1	CENTER DRIVER MESH COVER	
12	1	CENTER PASSENGER MESH COVER	
13	2	FRAME BOLT PLATE	
14	1	LED CENTER BAR DRIVER BRACKET	
15	1	LED CENTER BAR PASSENGER BRACKET	
16	1	OUTER DRIVER MESH COVER	
17	1	OUTER PASSENGER MESH COVER	
18	1	CENTER LED MESH COVER	
19	16	M12 SERRATED FLANGE NUT	
20	14	M12 HEX BOLT	
21	18	M12 LOCK WASHER	
22	18	M12 FLAT WASHER	
23	4	M12 HEX HEAD BOLT	
24	8	M6 HEX HEAD BOLT	
25	4	M6 SPLIT LOCK WASHER	
26	16	M6 FLAT WASHER	
27	4	M6 NYLOCK HEX NUT	
28	12	M6 SERRATED FLANGE HEX NUT	
29	12	M6 HEX DRIVE FLAT HEAD SCREWS	

ANTI-SEIZE LUBRICANT MUST BE USED ON ALL STAINLESS STEEL FASTENERS TO PREVENT THREAD DAMAGE AND GALLING



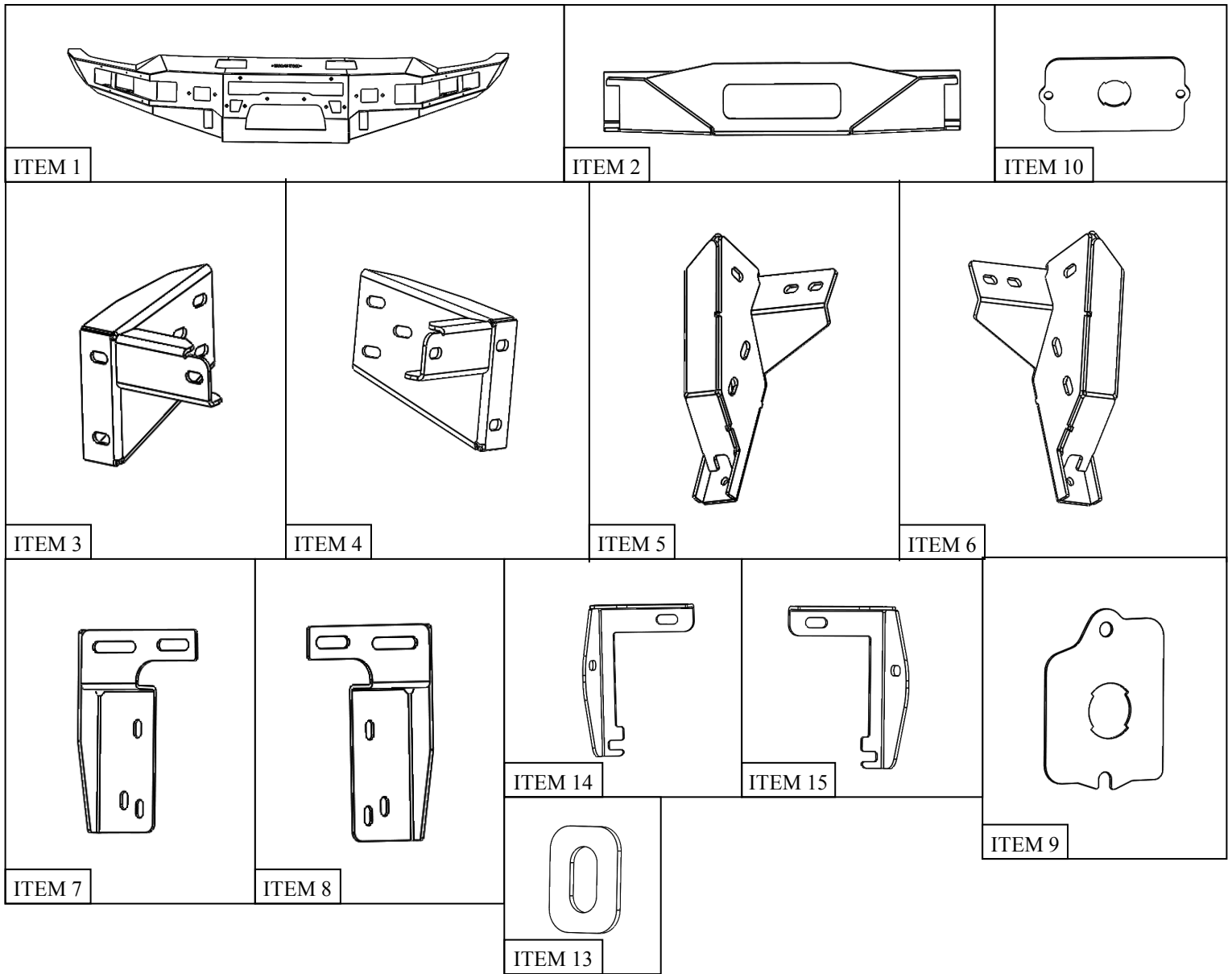

PROCEDURE

1. Remove contents from box, verify if all parts listed are present and free from damage.
Carefully read and understand all instructions before attempting installation.
Failure to identify damage before installation could lead to a rejection of any claim.
2. Open the hood of the vehicle and remove the plastic cover at the front using a pry tool. See **Figure 1**.
3. Remove the four bolts holding the grille in place. See **Figure 2**.
4. Remove 2 bolts attaching wheel well cover to filler panel. See **Figure 3**.

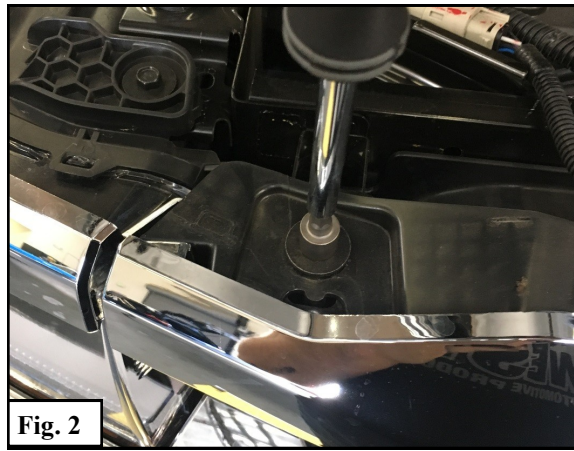

5. Pry off fenders to access the filler panel clips. See **Figure 4**.
6. Pry filler panel off removing any necessary bolts. See **Figure 5**.
7. Disconnect any electrical plugs and any bolts still attaching the grill to the vehicle. See **Figure 6**.

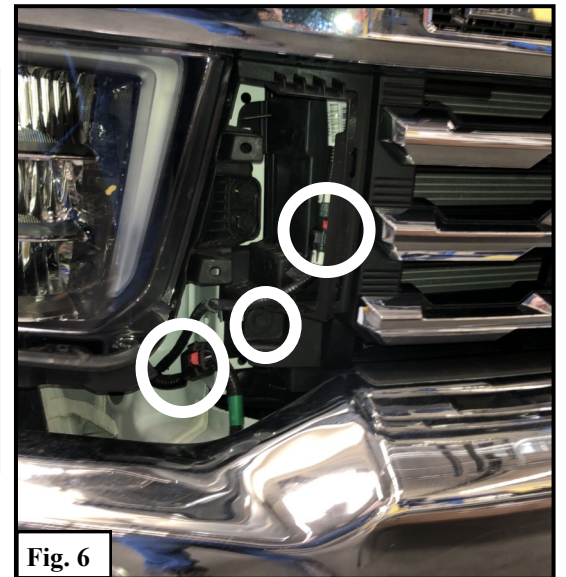
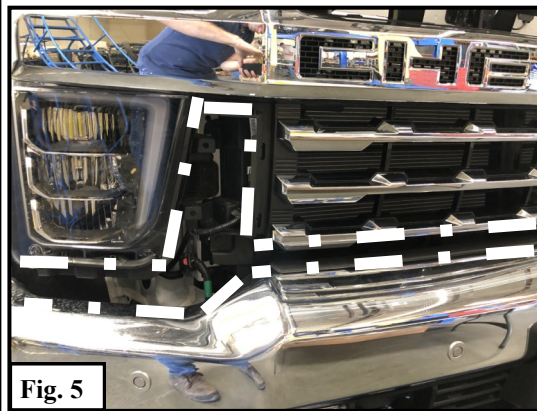

9. Remove 4 upper bumper bolts attaching the bumper to the frame and remove 2 bottom bolts attaching bumper arm to the frame. See **Figure 7 & 8**.
10. Remove Bumper.

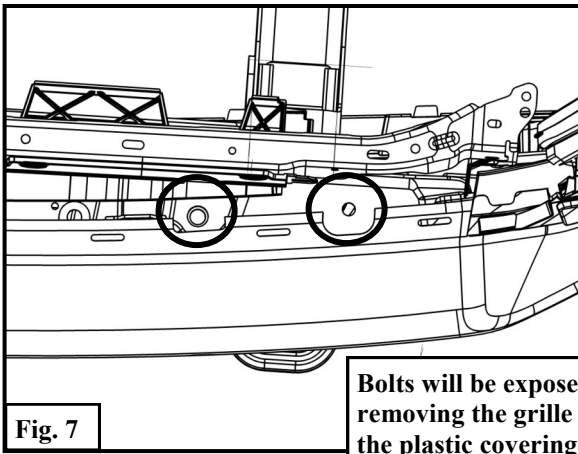

Fig. 7

Bolts will be exposed after removing the grille and lifting the plastic covering them

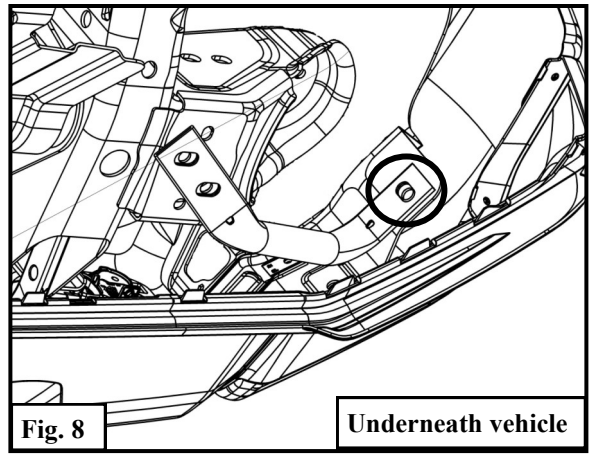

Fig. 8

Underneath vehicle

11. Once the bumper is removed, remove the sensors, sensor wiring harness, and the OEM fog lights. Remove the sensors carefully and make sure to pay attention to the sensor orientation since they must be reinstalled in that orientation. See **Figure 10 & 11**.
12. After you remove the sensors and harness, reinstall them on the new bumper. See **Figures 19** for a reference on routing the harness through the bumper and how to install the parking sensors.

13. Remove OE bumper brackets and Aerodynamic Active Shutters carefully as they are fragile. See **Figure 9**.
Note: Removal of Aerodynamic Active shutters may cause Check Engine Light to turn on. Be sure to complete step 16.



Fig. 9

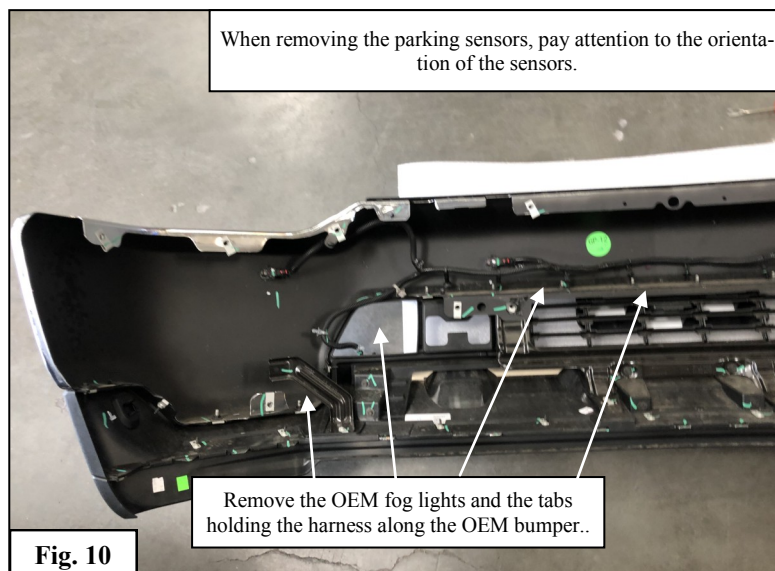

When removing the parking sensors, pay attention to the orientation of the sensors.

Remove the OEM fog lights and the tabs holding the harness along the OEM bumper..

Fig. 10

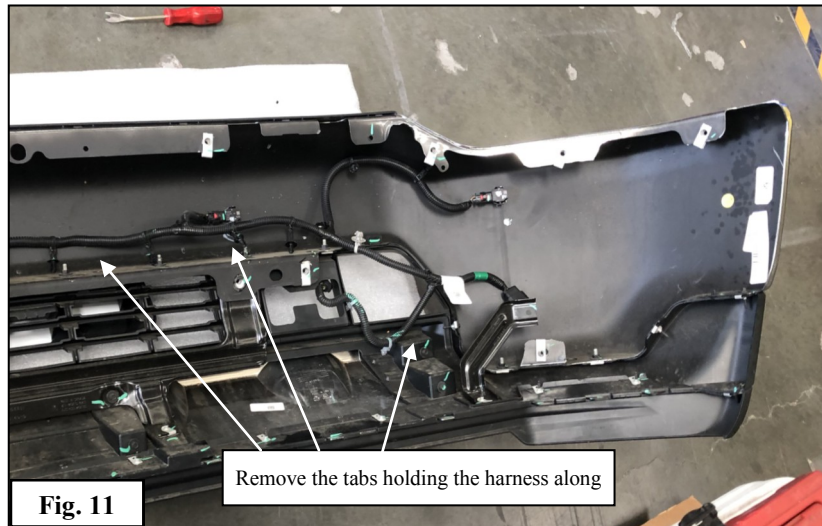

Fig. 11

14. Remove the factory tow hooks. See **Figure 12**.

15. Locate and install the Winch Tray Mounting Brackets loosely (5-6) with the provided M12 hardware (19-23). See **Figure 13 & 14** for reference. Repeat for passenger side.

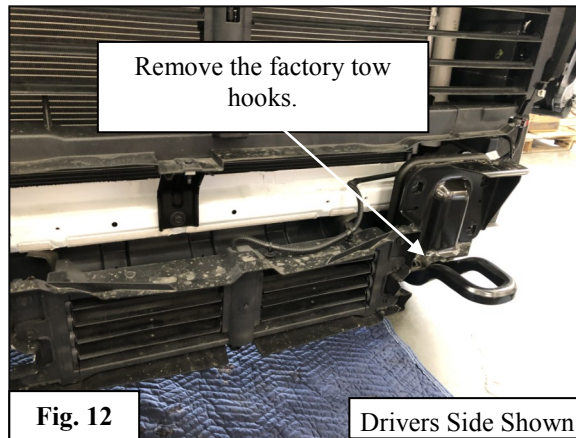
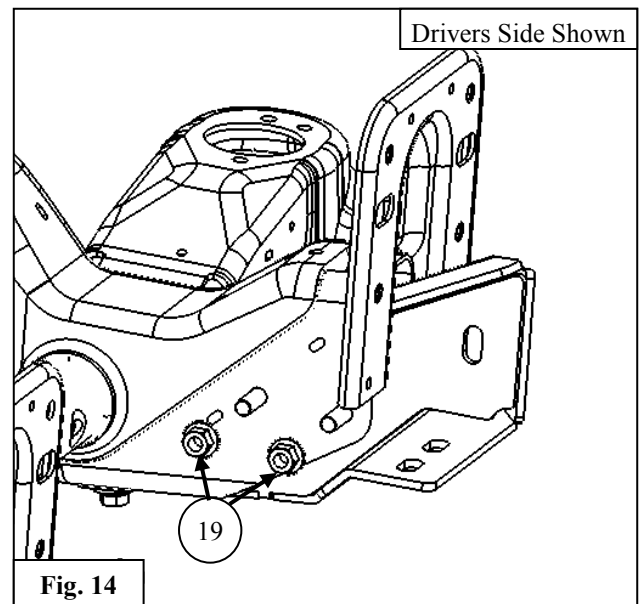
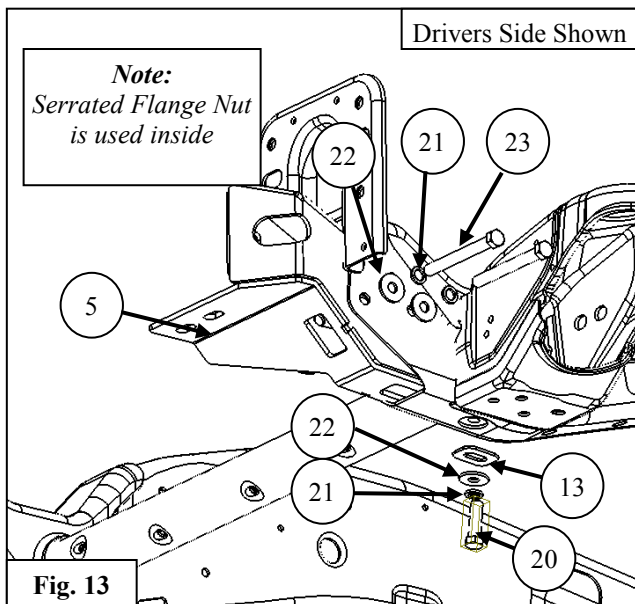
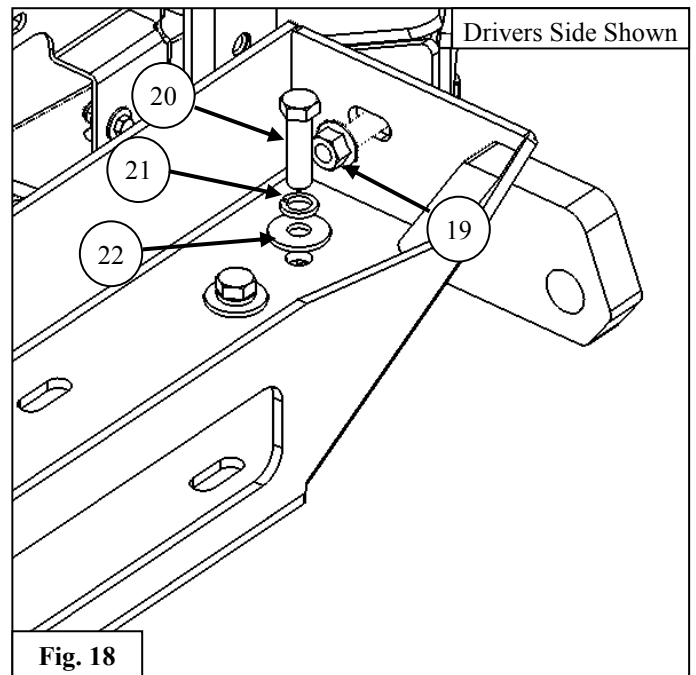
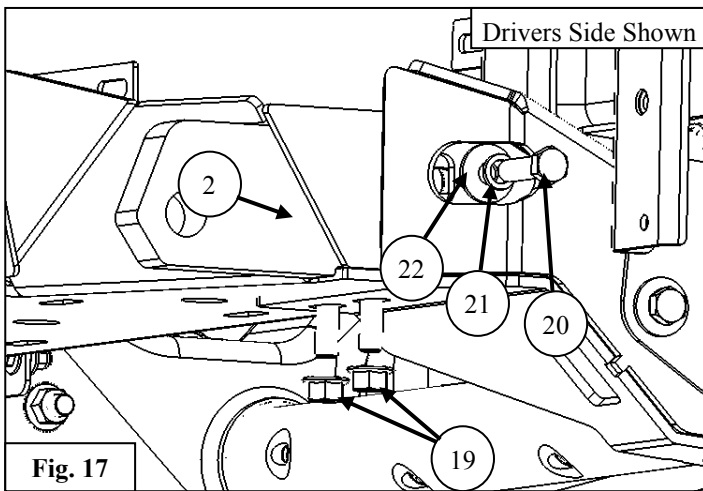
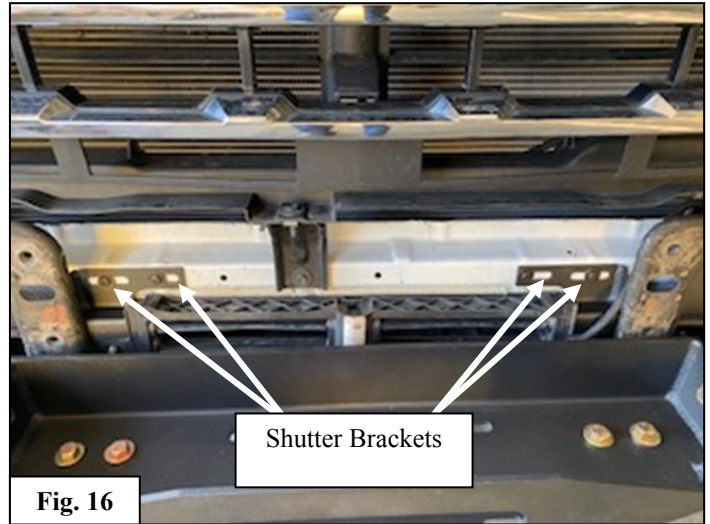
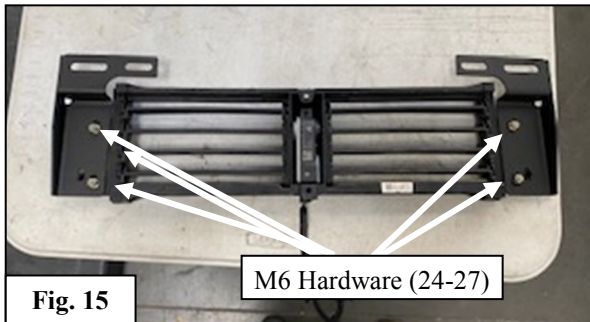

Fig. 12

Drivers Side Shown



16. Locate the OEM Aerodynamic Active Shutters and the Shutter Relocator Brackets (7-8) and install the shutters to the brackets with the provided M6 hardware (24-27). See **Figure 15 & 16** for reference. Adjust as needed.
17. Locate the Winch Tray (2) and install the Winch Tray onto the Winch Tray Brackets with the provided M12 hardware (19-23). See **Figure 16, 17, and 18** for reference. *Note: If you are installing a winch, do so now.*
18. Install all of the bumper accessories prior to installing the bumper onto the vehicle. See **Figure 18 & 19** for reference on installing the LED Center Brackets (14-15).
19. Reinstall the Parking Sensors if equipped in the same orientation that they were removed using the OEM parking sensor retainers. See **Figure 20** for reference. *Note: If parking sensors are not equipped you can use the Center and Outer mesh covers for the openings in the bumper.*



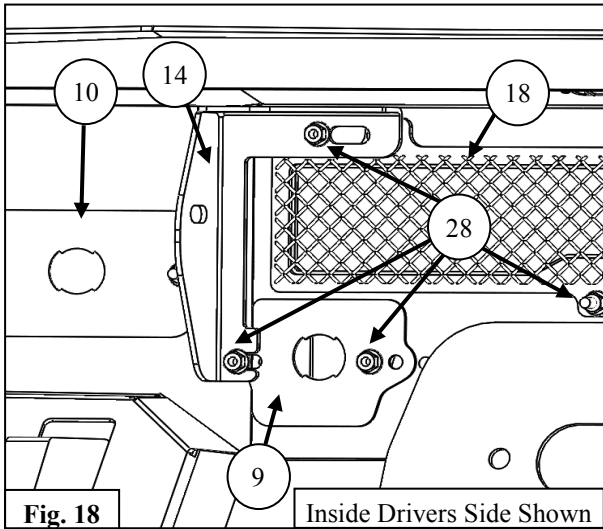

Fig. 18

Inside Drivers Side Shown

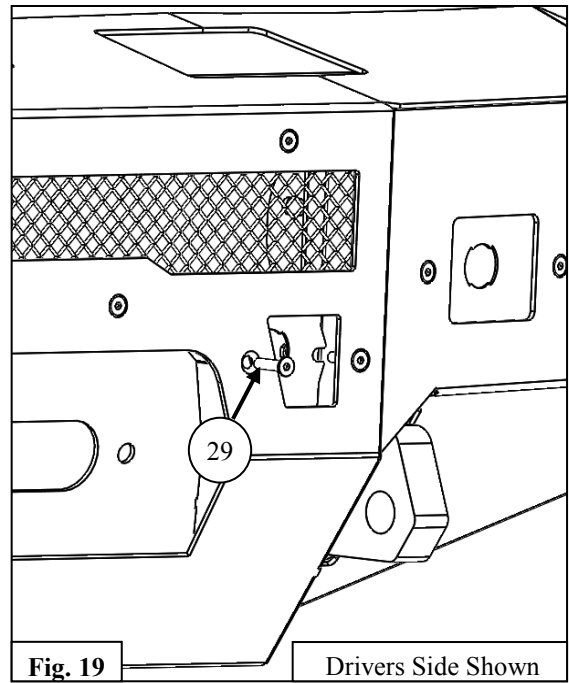

Fig. 19

Drivers Side Shown



Fig. 20

OEM Sensor Retainers with OEM Sensors

20. Using the OEM hardware, install the Mounting Brackets (3-4) onto the vehicle. See **Figure 21** for reference.
 21. With help of a second person, install the Pro-Series Bumper onto the Mounting Brackets using the provided M12 hardware (19-22). See **Figure 22-23** for reference.

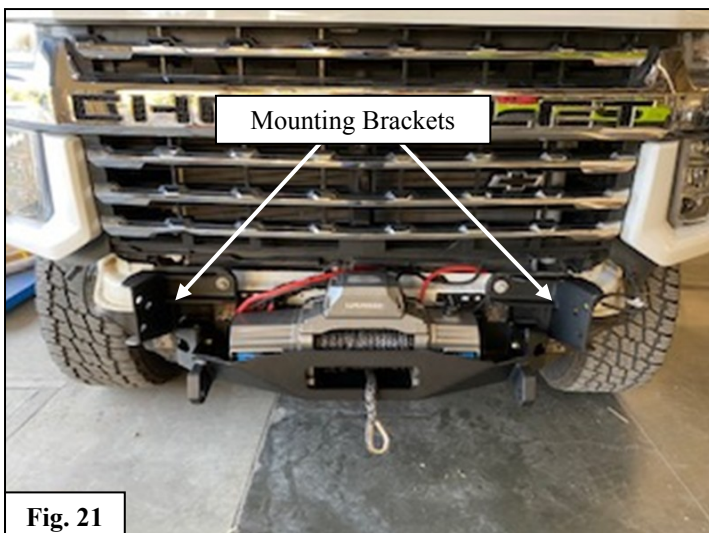

Fig. 21

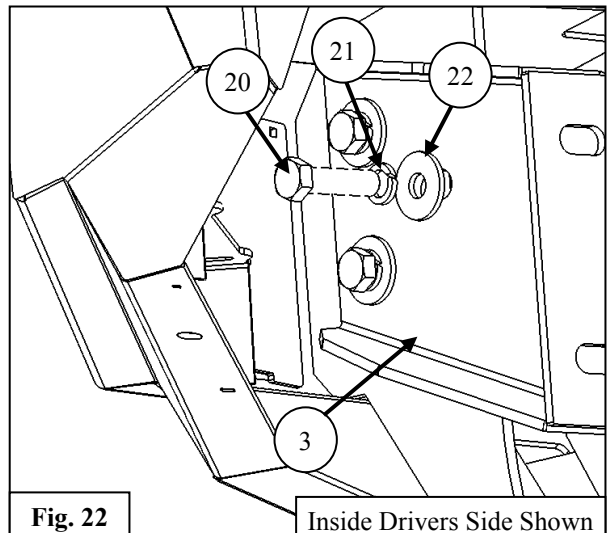
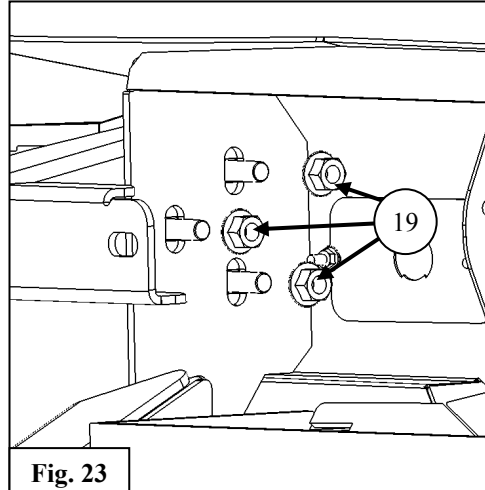

Fig. 22

Inside Drivers Side Shown

22. **Note:**

- Route the parking sensor harness carefully and secure it with zip ties.
- The HYPERQ LED Auxiliary Lights are sold separately. To install, use the provided hardware in the light kit.



COMPLETE INSTALLATION



CARE INSTRUCTIONS

- REGULAR WAXING IS RECOMMENDED. DO NOT USE ANY TYPE OF POLISH OR WAX THAT MAY CONTAIN ABRASIVES.
- STAINLESS STEEL PRODUCTS CAN BE CLEANED WITH MILD SOAP AND WATER. STAINLESS STEEL POLISH SHOULD BE USED TO POLISH SMALL SCRATCHES.
- GLOSS BLACK FINISHES SHOULD BE CLEANED WITH MILD SOAP AND WATER.

WESTIN



WARNING



Failure to follow these instructions could lead to death, personal injury, and / or property damage.

Failure to follow these instructions could lead to death, personal injury, and / or property damage.

FASTENERS:

All Westin supplied fasteners must be utilized and installed in accordance with the installation instructions and apply torque to the specifications as defined. **DOUBLE CHECK ALL FASTENERS BEFORE INITIAL USE, AND PERIODICALLY IN THE FUTURE TO ENSURE PROPER FUNCTION AND SAFETY.**

DRILLING:

Most Westin products do not require drilling for installation. If drilling is defined as required, use caution when drilling a vehicle. **FAILURE TO REVIEW AN AREA TO BE DRILLED MAY RESULT IN PERSONAL INJURY AND/OR INJURY TO OTHERS AS WELL AS VEHICLE DAMAGE.**

EYE PROTECTION:

ALWAYS WEAR SAFETY GLASSES OR GOGGLES DURING THE INSTALLATION PROCESS TO AVOID PERSONAL INJURY.

MAXIMUM TOWING/CARRYING CAPACITY: (if applicable)

The Westin Receiver Hitches will have a visible tow rating label affixed directly on the product. User should never exceed the vehicle manufacturers maximum tow and weight rating regardless of the capacity of the hitch. **FAILURE TO FOLLOW THESE GUIDELINES WILL VOID THE WESTIN WARRANTY AND MAY RESULT IN PERSONAL INJURY AND/OR INJURY TO OTHERS AS WELL AS VEHICLE DAMAGE.**

FOR CALIFORNIA RESIDENTS ONLY-PROP 65 WARNING:

Some products may contain chemicals such as DEHP, which can cause cancer, birth defects or other reproductive harm.

