

INSTALLATION INSTRUCTIONS

PRO-SERIES FRONT BUMPER



APPLICATION: 2017-2020 Ford F250/350

PART NUMBER: 58-411175

CONTENT			
ITEM	QUANTITY	DESCRIPTION	TOOLS NEEDED
1	1	PRO SERIES FRONT BUMPER	MM SOCKET
2	1	WINCH TRAY	
3	1	LED LIGHT COVER	RATCHET
4	1	DRIVER LED LIGHT BRACKET	TORQUE WRENCH
5	1	PASSENGER LED LIGHT BRACKET	
6	1	DRIVER MAIN BRACKET	
7	1	PASSENGER MAIN BRACKET	
8	1	DRIVER SUPPORT BRACKET	
9	1	PASSENGER SUPPORT BRACKET	
10	6	M14 HEX HEAD BOLT	
11	12	M14 FLAT WASHERS	
12	6	M14 HEX NUT	
13	6	M14 LOCK WASHER	
14	14	M12 SERRATED FLANGE NUT	
15	14	M12 HEX HEAD BOLT	
16	4	M6 HEX HEAD BOLTS	
17	8	M6 FLAT WASHER	
18	8	M6 SERRATED FLANGE NUT	
19	4	M6 HEX DRIVE FLAT HEAD SCREWS	
20	14	M12 FLAT WASHER	

ANTI-SEIZE LUBRICANT MUST BE USED ON ALL STAINLESS STEEL FASTENERS TO PREVENT THREAD DAMAGE AND GALLING

PROCEDURE

1. Remove contents from box, verify if all parts listed are present and free from damage.
Carefully read and understand all instructions before attempting installation.
Failure to identify damage before installation could lead to a rejection of any claim.



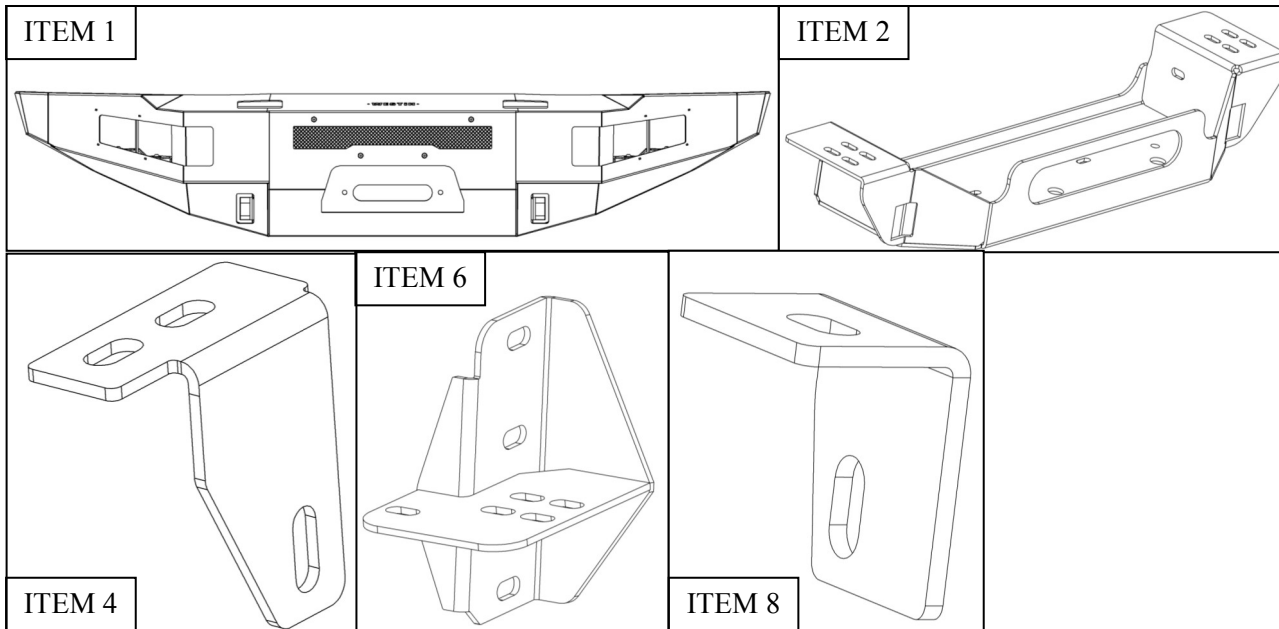

2. Remove the license plate and bracket. On models with factory fog lights, unplug both lights. Release the wiring harness from the clips attached to the back of the bumper, **(Figures 1 & 2)**. Move harness away from bumper.

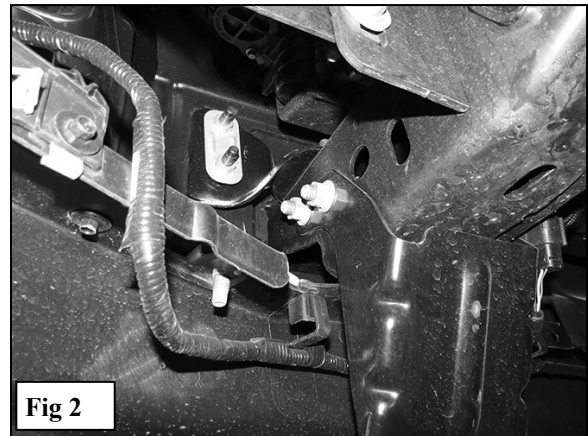
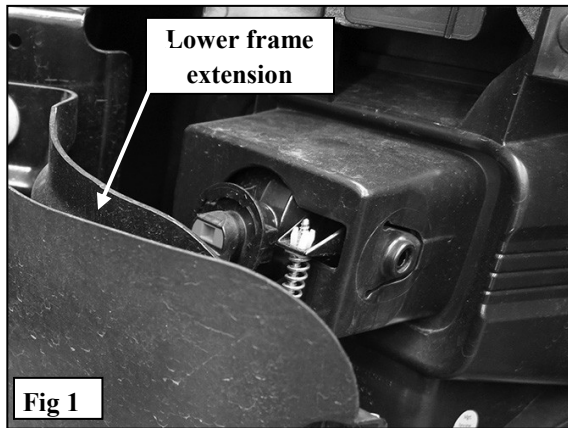

3. Next, remove the plastic lower air dam from the bottom of the bumper, (**Figure 3**). Remove the outer bumper supports attaching the outer ends of the bumper to the sides of the frame, (**Figure 4**). Remove the plastic covers from the tow hooks to uncover the bumper bolts, (**Figure 5**).

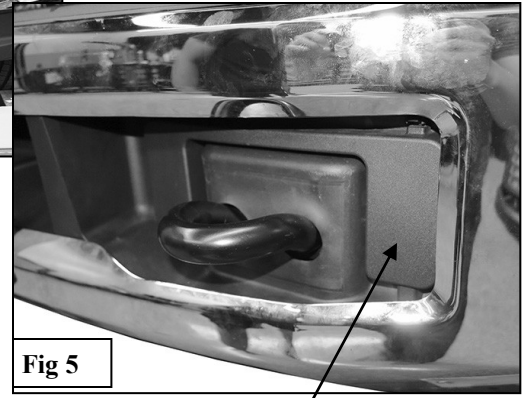
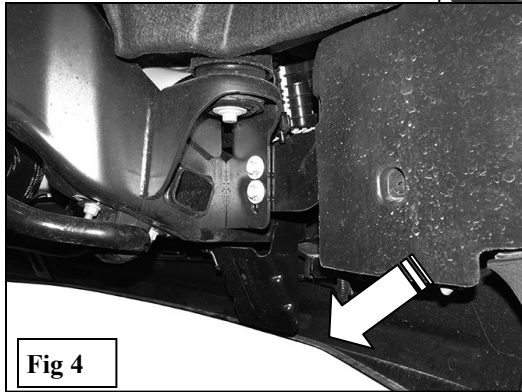
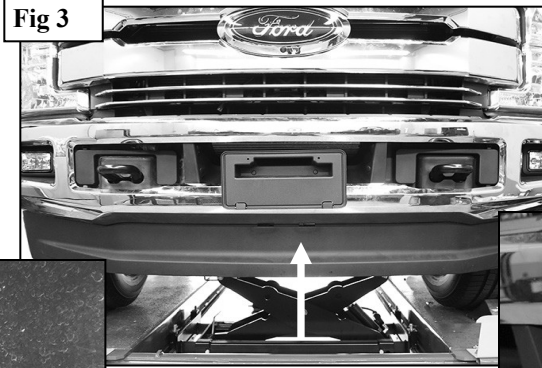

4. Place blocks or jack stands under the front bumper to support it during mounting bolt removal. Once the bumper has been safely supported, remove the (8) factory bumper bolts, (**Figure 6**).

WARNING! Assistance is required to hold the bumper in place during bolt removal to prevent the bumper from falling. Carefully slide the bumper off over the tow hooks.

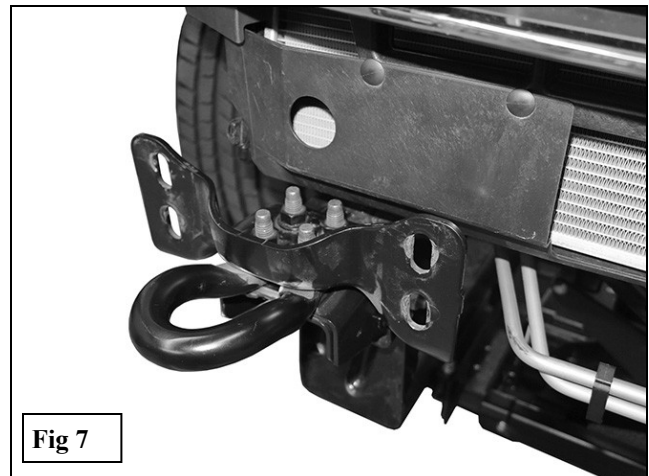
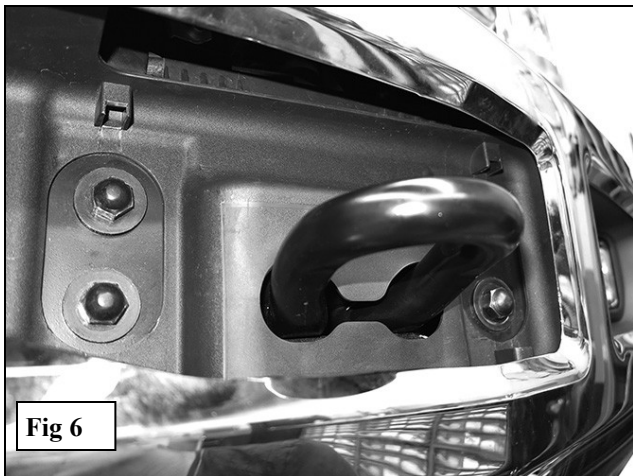

5. Remove the passenger/right side tow hook from the end of the frame, (**Figure 7**). Next, remove the (4) factory hex nuts, lower frame extension and double bolt plates from the end of the frame, (**Figures 2 & 7**). Repeat for Driver Side.

5. If your vehicle is equipped with active cruise control system, you must purchase **PN: 58-40025** to relocate to grille area.
6. If your vehicle is not equipped with cruise control sensors, then proceed to the next step.

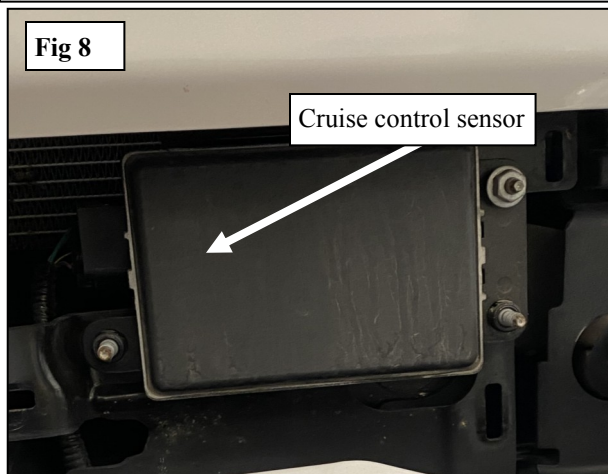

7. Using Supplied M12 hardware, loosely assemble the winch tray and main mounting brackets to the frame on the truck. See **Figure 9-11**

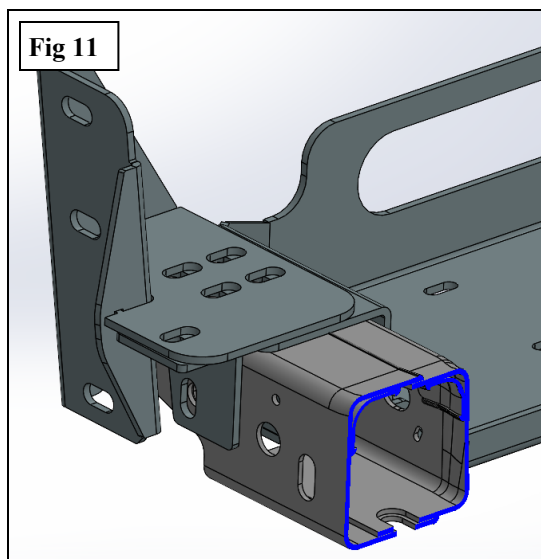
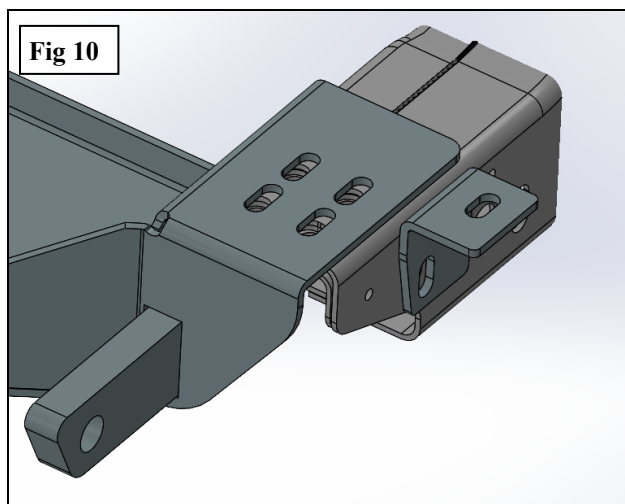
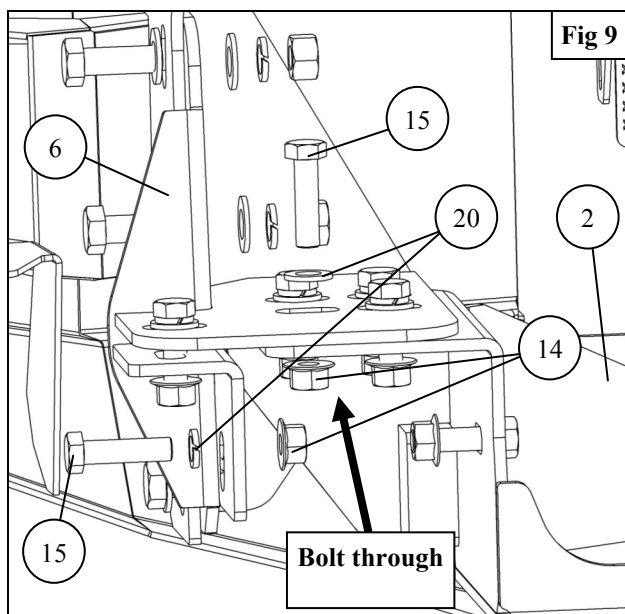
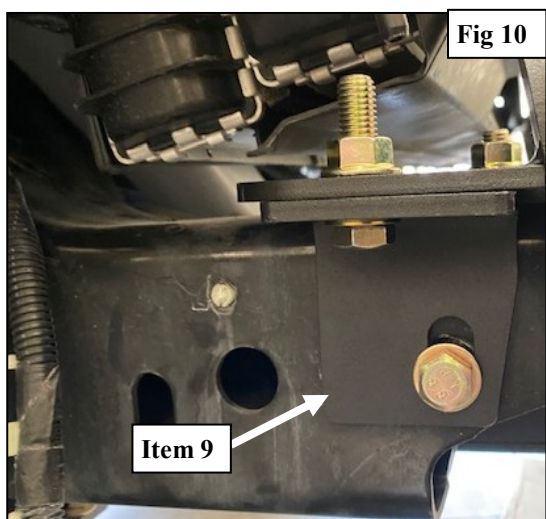

8. Mount your winch and winch accessories at this time.
9. If installing a light bar, install using the supplied LED light brackets and supplied M6 hardware, if applicable. Install light per manufacturers recommendation. **See Figure 12**
10. If you are not installing light bar, install the led light mesh cover using supplied M6 hardware. **See Figure 12**
11. If installing light pods, do so at this time.

Fig 12

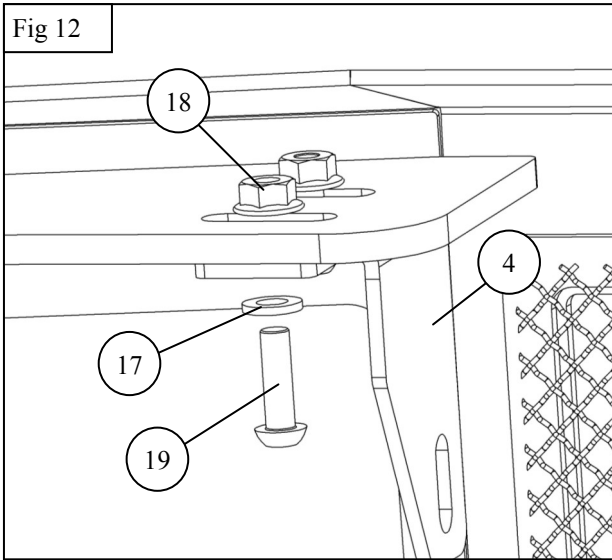
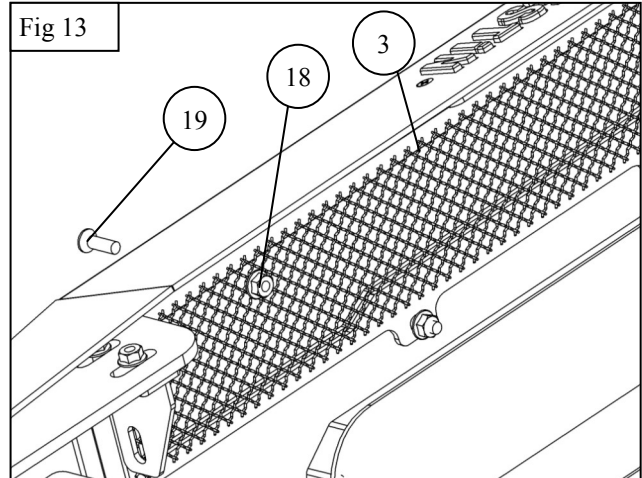
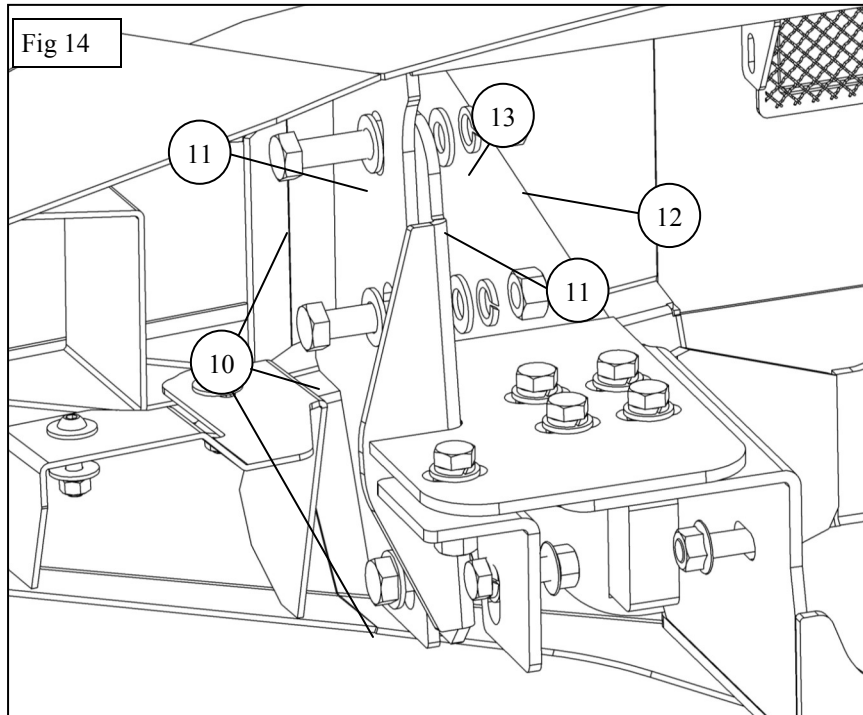

Fig 13



12. Using supplied M14 bolts, loosely assemble the bumper to the mounting brackets. **See Figure 13**

Fig 14



13. Adjust the bumper as needed and torque hardware as specified: M6 to 5-7 ft-lbs, M12 to 50-55 ft-lbs, M14 to 90-95 ft-lbs

INSTALLATION COMPLETE



CARE INSTRUCTIONS

- REGULAR WAXING IS RECOMMENDED. DO NOT USE ANY TYPE OF POLISH OR WAX THAT MAY CONTAIN ABRASIVES.
- STAINLESS STEEL PRODUCTS CAN BE CLEANED WITH MILD SOAP AND WATER. STAINLESS STEEL POLISH SHOULD BE USED TO POLISH SMALL SCRATCHES.
- GLOSS BLACK FINISHES SHOULD BE CLEANED WITH MILD SOAP AND WATER.



WARNING



Failure to follow these instructions could lead to death, personal injury, and / or property damage.

Failure to follow these instructions could lead to death, personal injury, and / or property damage.

FASTENERS:

All Westin supplied fasteners must be utilized and installed in accordance with the installation instructions and apply torque to the specifications as defined. **DOUBLE CHECK ALL FASTENERS BEFORE INITIAL USE, AND PERIODICALLY IN THE FUTURE TO ENSURE PROPER FUNCTION AND SAFETY.**

DRILLING:

Most Westin products do not require drilling for installation. If drilling is defined as required, use caution when drilling a vehicle. **FAILURE TO REVIEW AN AREA TO BE DRILLED MAY RESULT IN PERSONAL INJURY AND/OR INJURY TO OTHERS AS WELL AS VEHICLE DAMAGE.**

EYE PROTECTION:

ALWAYS WEAR SAFETY GLASSES OR GOGGLES DURING THE INSTALLATION PROCESS TO AVOID PERSONAL INJURY.

MAXIMUM TOWING/CARRYING CAPACITY: (if applicable)

The Westin Receiver Hitches will have a visible tow rating label affixed directly on the product. User should never exceed the vehicle manufacturers maximum tow and weight rating regardless of the capacity of the hitch. **FAILURE TO FOLLOW THESE GUIDELINES WILL VOID THE WESTIN WARRANTY AND MAY RESULT IN PERSONAL INJURY AND/OR INJURY TO OTHERS AS WELL AS VEHICLE DAMAGE.**

FOR CALIFORNIA RESIDENTS ONLY-PROP 65 WARNING:

Some products may contain chemicals such as DEHP, which can cause cancer, birth defects or other reproductive harm.

