

# INSTALLATION INSTRUCTIONS

## PRO-MOD BUMPER



**APPLICATION:**  
2018-2019 Ford F-150  
**PART NUMBER:**  
58-41065

<b>CONTENT</b>			
<b>ITEM</b>	<b>QUANTITY</b>	<b>DESCRIPTION</b>	<b>TOOLS NEEDED</b>
1	2	SIDE POD ASSEMBLY (1 DRIVER, 1 PASSENGER)	10MM SOCKET
2	2	MESH SIDE COVERS (1 DRIVER, 1 PASSENGER)	10MM WRENCH
3	1	CENTER SECTION	13MM SOCKET
4	1	SKID PLATE	13MM WRENCH
5	1	DRIVER MOUNTING BRACKET	16MM SOCKET
6	1	PASSENGER MOUNTING BRACKET	16MM WRENCH
7	1	DRIVER SUPPORT BRACKET	18MM SOCKET
8	1	PASSENGER SUPPORT BRACKET	19MM WRENCH
9	1	DRIVER SIDE STRAP	RATCHET
10	1	PASSENGER SIDE STRAP	TORQUE WRENCH
11	2	LED LIGHT BRACKET	
12	12	M6 BUTTON HEAD SCREW	
13	12	M6 FLAT WASHER	
14	12	M6 SERRATED FLANGE NUT	
15	12	M6 LOCK WASHER	
16	16	M8 FLAT WASHER	
17	10	M8 LOCK WASHER	
18	6	M8 SERRATED FLANGE NUT	
19	10	M8 BUTTON HEAD BOLTS	
20	6	M12 SERRATED FLANGE NUT	
21	6	M12 HEX BOLT	
22	6	M12 LOCK WASHER	
23	6	M12 FLAT WASHER	
24	6	M8 U-CLIP	
25	4	M10 HEX HEAD BOLT	
26	4	M10 SERRATED FLANGE NUT	
27	8	M10 FLAT WASHER	

**ANTI-SEIZE LUBRICANT MUST BE USED ON ALL STAINLESS STEEL FASTENERS TO PREVENT THREAD DAMAGE AND GALLING**



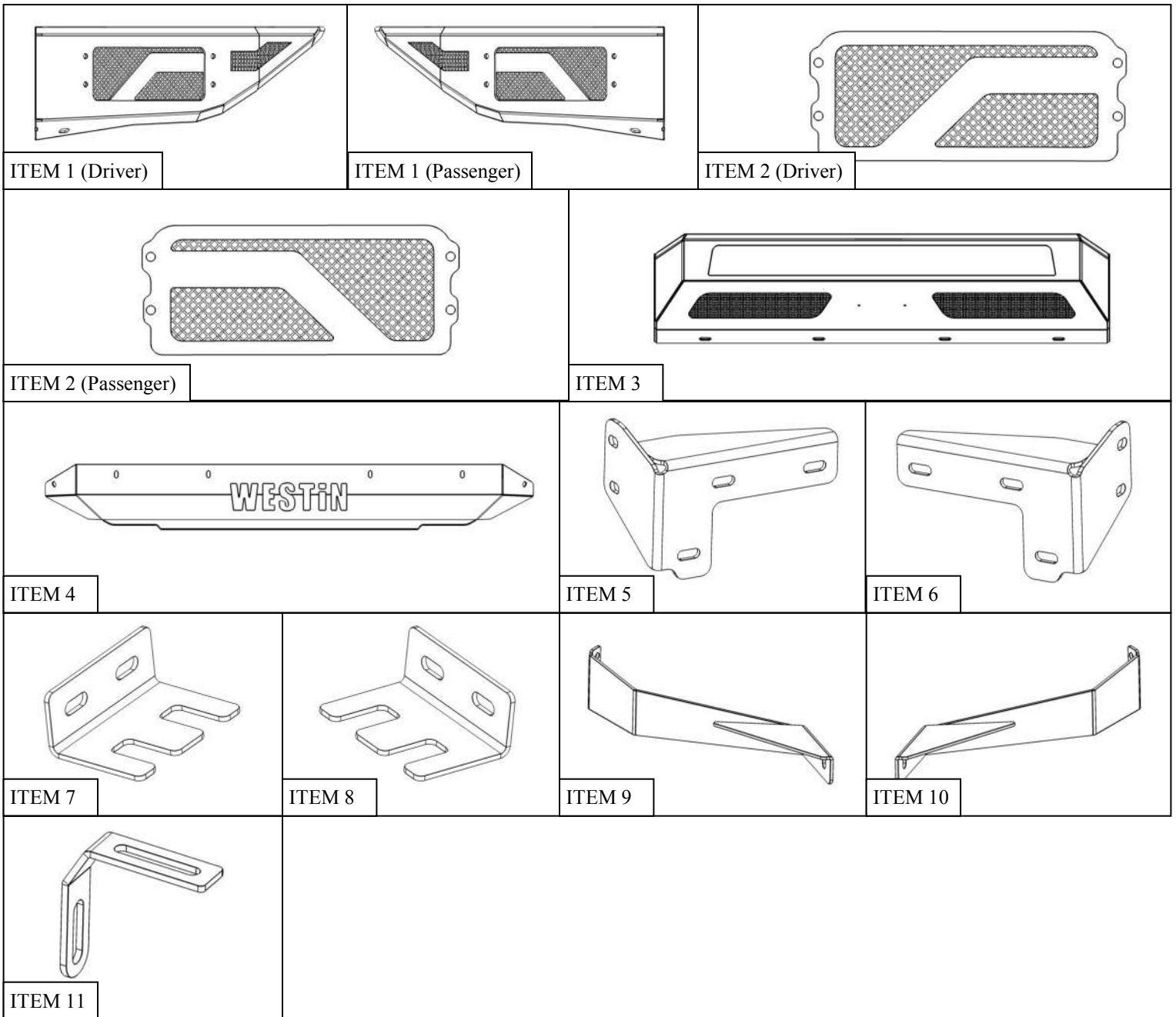

### PROCEDURE

1. Remove contents from box, verify if all parts listed are present and free from damage.  
Carefully read and understand all instructions before attempting installation.  
**Failure to identify damage before installation could lead to a rejection of any claim.**



Fig. 1

2. Remove plastic caps from stock bumper. See **Figure 1**.
3. Remove the three bolts indicated in **Figures 2 & 3** from each side of the vehicle.
4. Remove original bumper making sure to disconnect any electrical connections to the bumper.

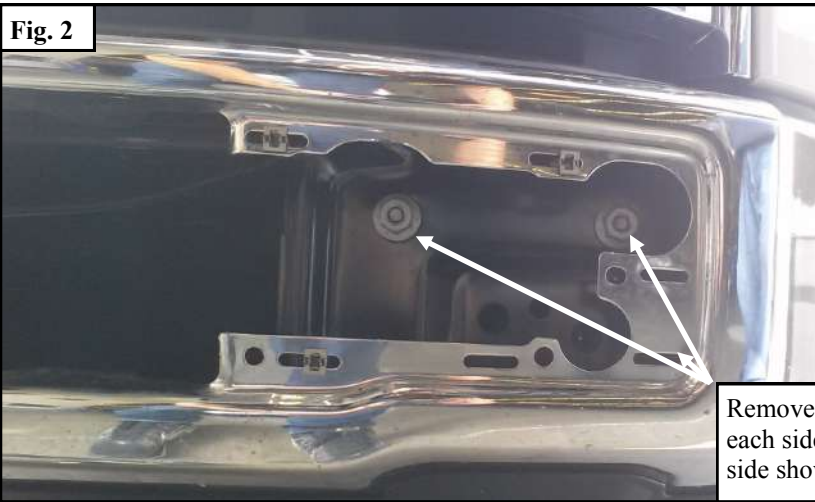

Fig. 2

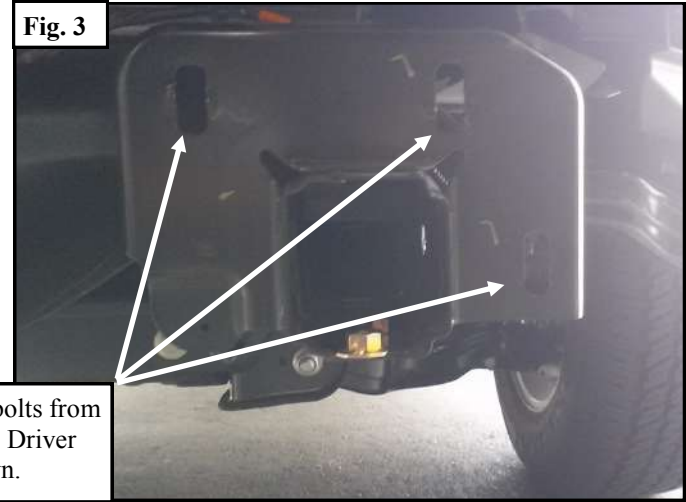
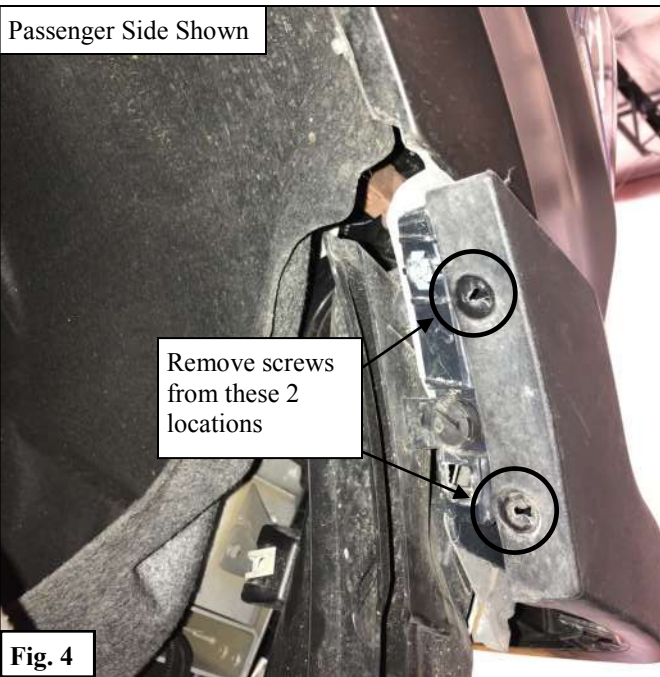

Fig. 3

Remove bolts from each side. Driver side shown.

5. Remove the two small trim screws from the plastic trim pieces on either side of the vehicle. See **Figure 4**.
6. Carefully pull back the trim to access the two bolts behind it for the air dam; remove these two bolts along with the bolt on the front facing side of the air dam. See **Figures 5 & 6**. Remove the air dam from both sides.



Passenger Side Shown

Remove screws from these 2 locations

Fig. 4

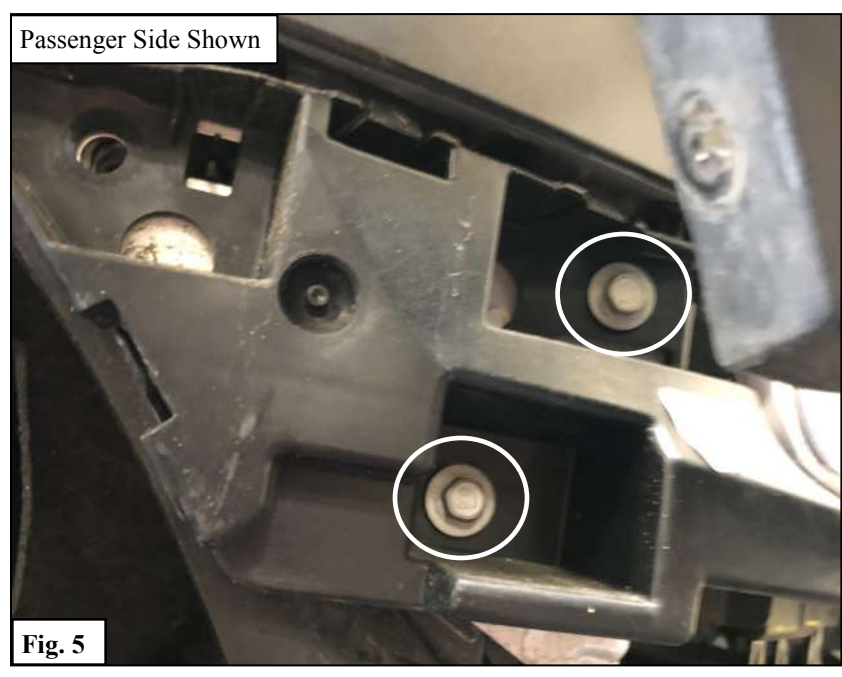

Passenger Side Shown

Fig. 5

7. Reinstall the plastic trim piece as removed in **Step 5**.
8. Loosely install the Mounting Brackets (5,6) to the frame using the factory hardware along with the supplied M12 Hardware. See **Figure 7**.

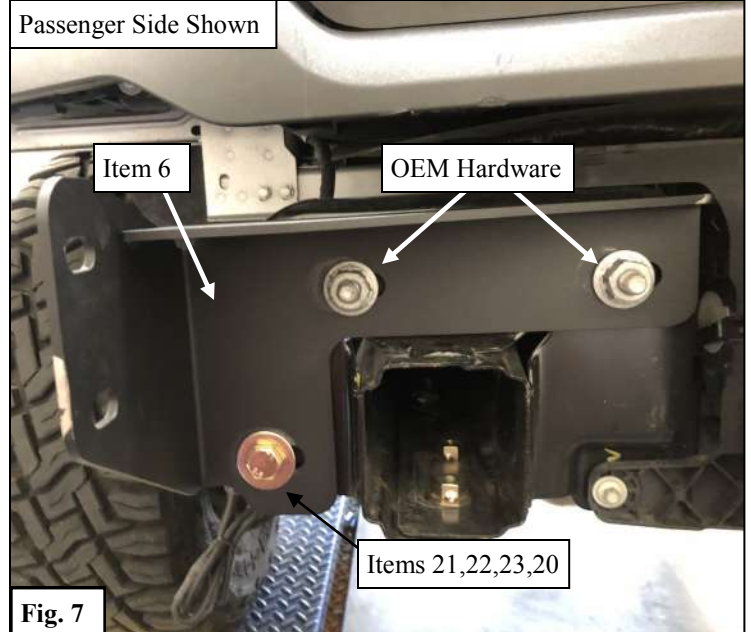
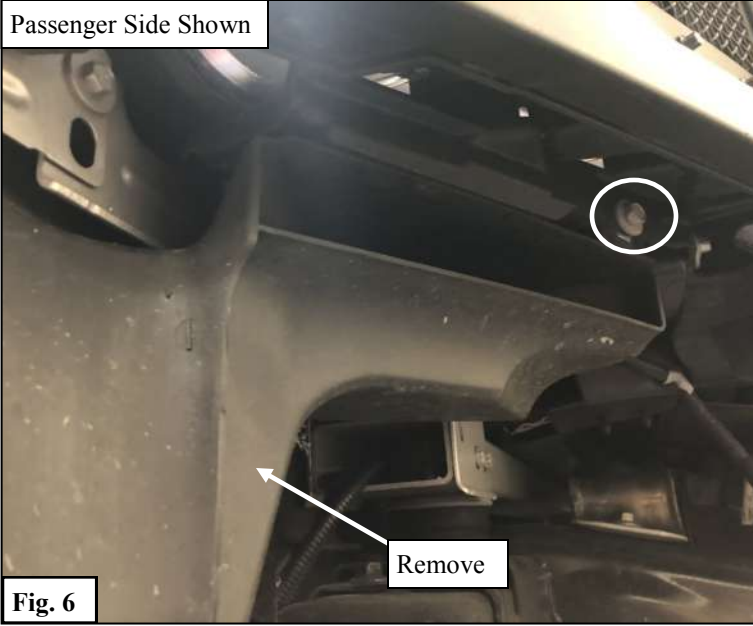

9. Use the supplied M10 Hardware to attach each Side Pod Assembly (1,2) to the Center Section (3). See **Figure 8**.
10. Use the supplied M6 Hardware to attach the LED Brackets (11) to the center section. See **Figure 9**. *Note: If installing an LED Light Bar (sold separately), install it at this time.*

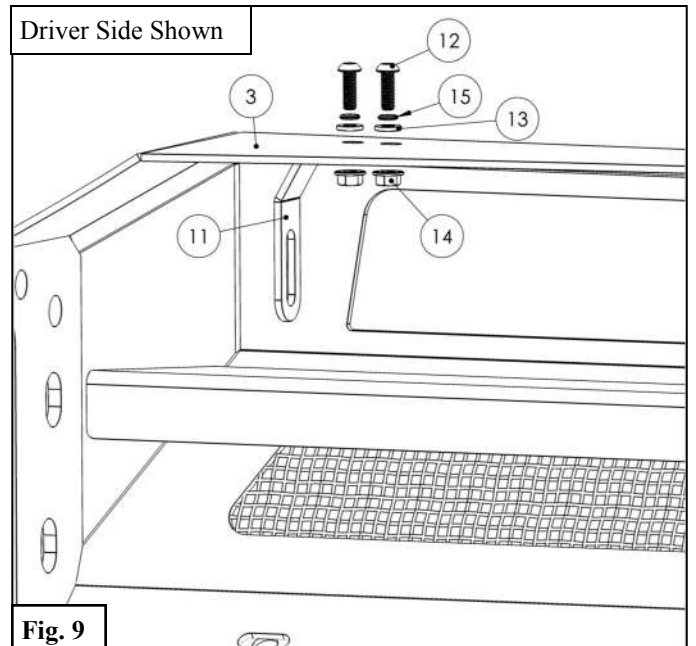
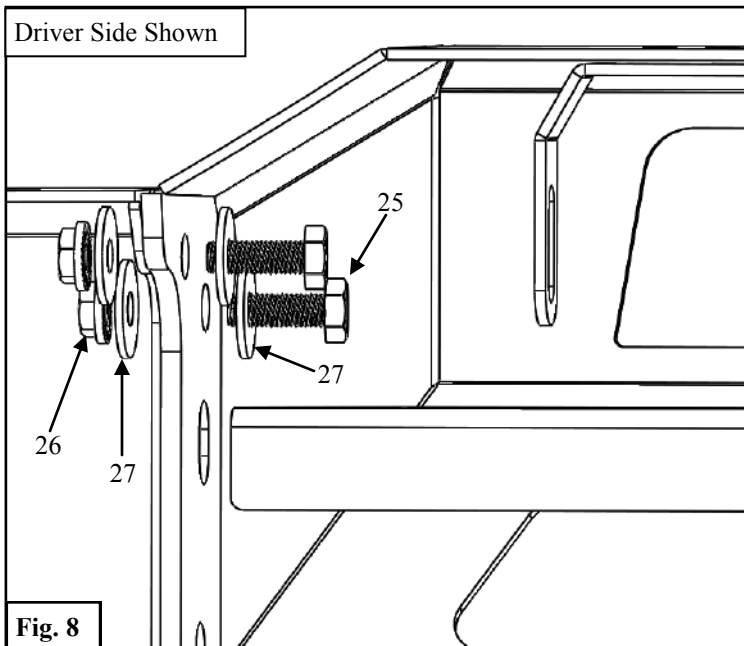



11. Loosely install the bumper assembly to the Mounting Brackets (5,6) using the supplied M12 Hardware. See **Figures 10 & 11.**

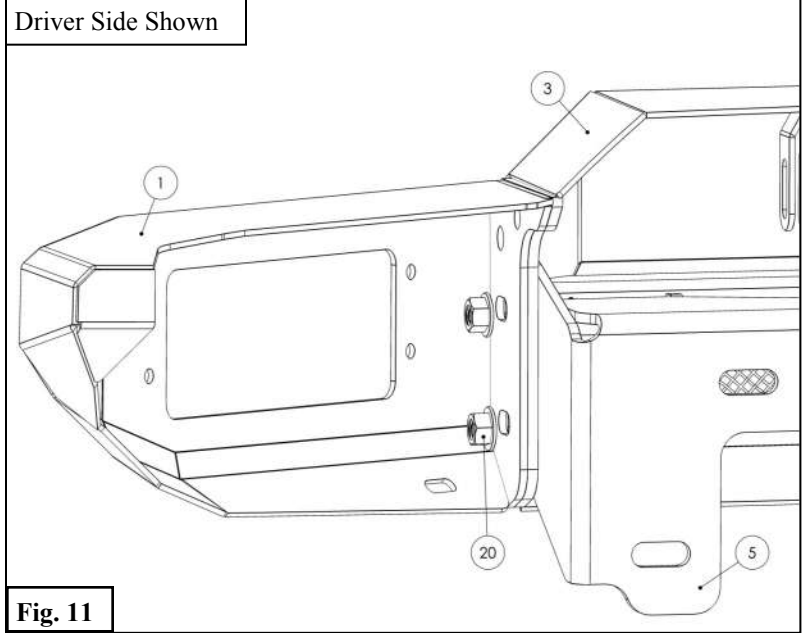
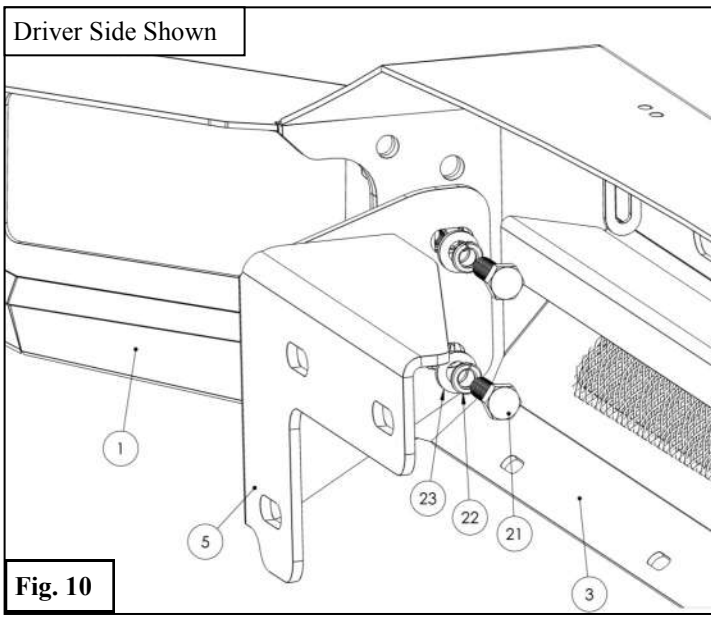

12. Loosely install the Support Brackets (7,8) to the frame of the vehicle using the factory hardware. See **Figure 12.**

13. Loosely attach the Side Straps (9,10) to the Support Brackets (7,8) using the supplied M8 Hardware. See **Figure 13.**

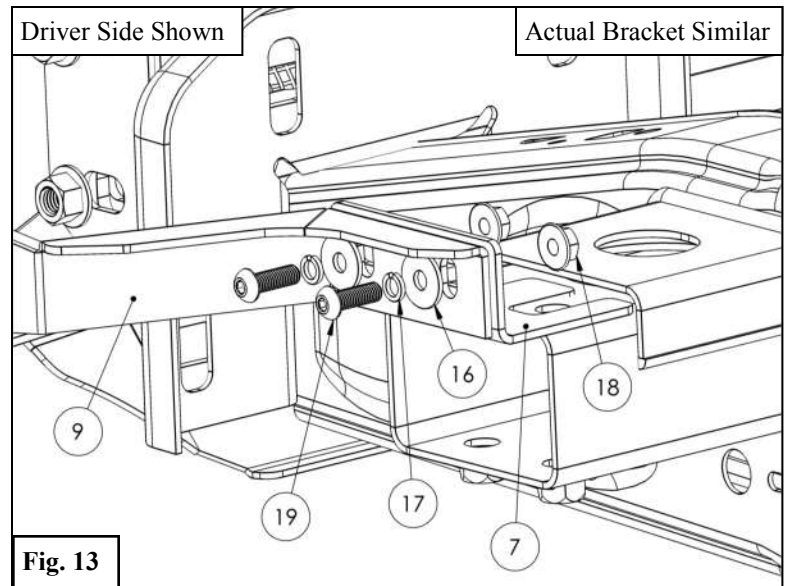
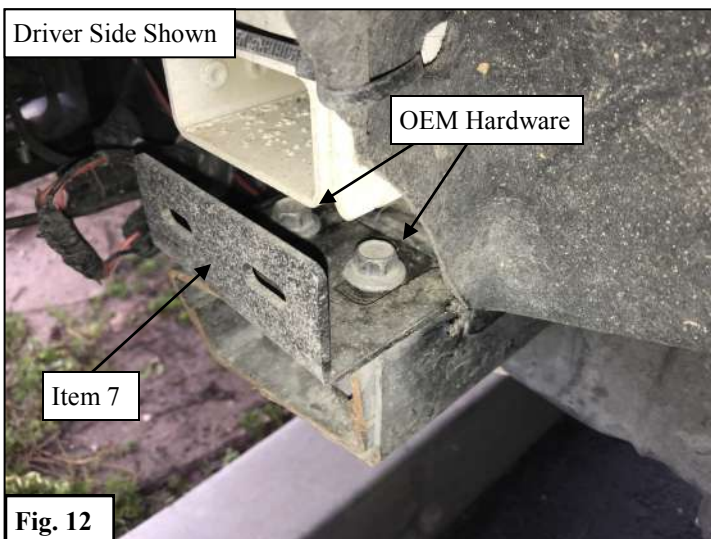

14. Attach the Mesh Side Covers (2) to the Bumper and Side Straps (9,10) using the supplied M6 Hardware. See **Figures 14 & 15**.

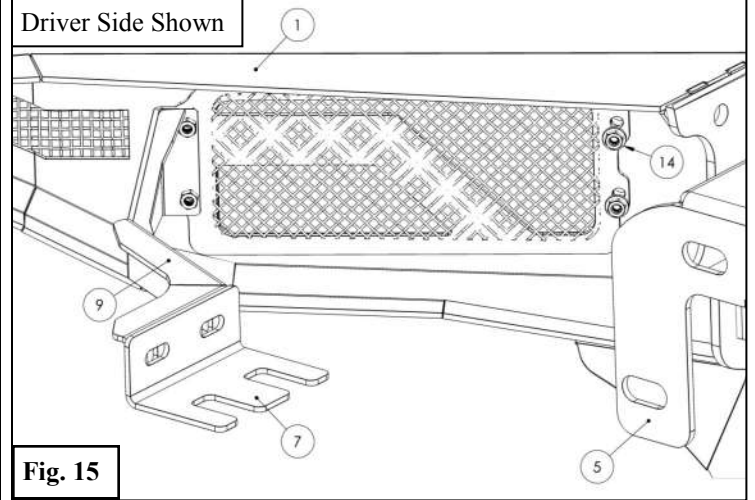
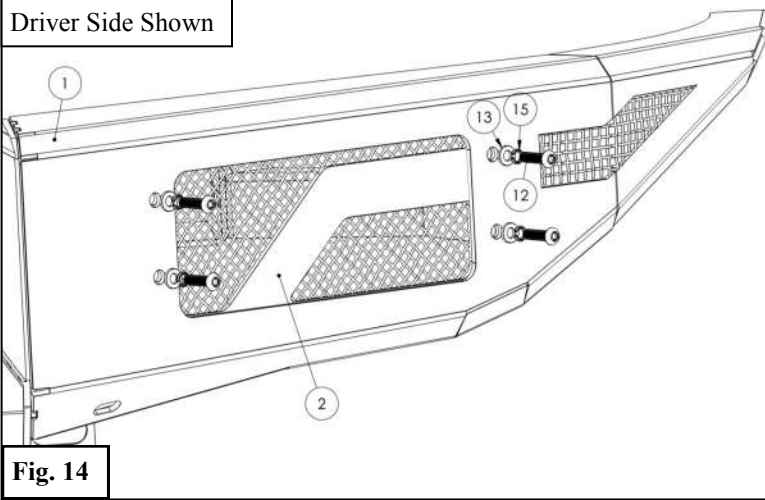

15. Attach the supplied M8 U-Clips (24) to the Bumper along the bottom edge as shown in **Figure 16**.

16. Attach the Skid Plate (4) to the U-Clips (24) using the supplied M8 Hardware. See **Figure 17**.

17. Align bumper as desired and torque all hardware as specified: M6 to 7 ft-lbs, M8 to 18 ft-lbs, M10 to 38 ft-lbs, M12 to 60 ft-lbs.

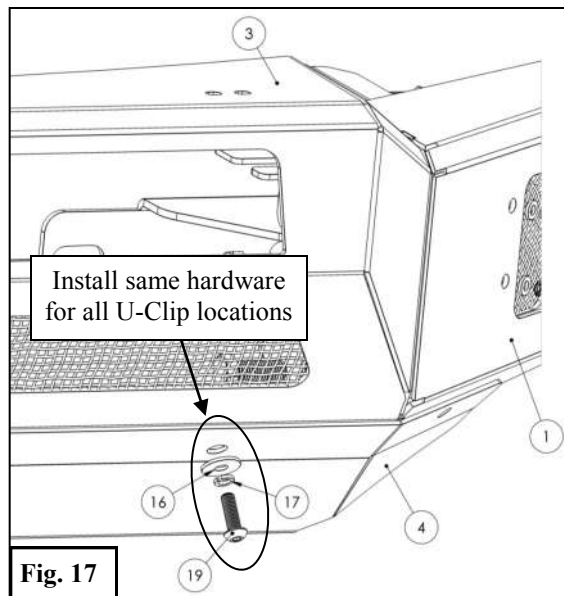
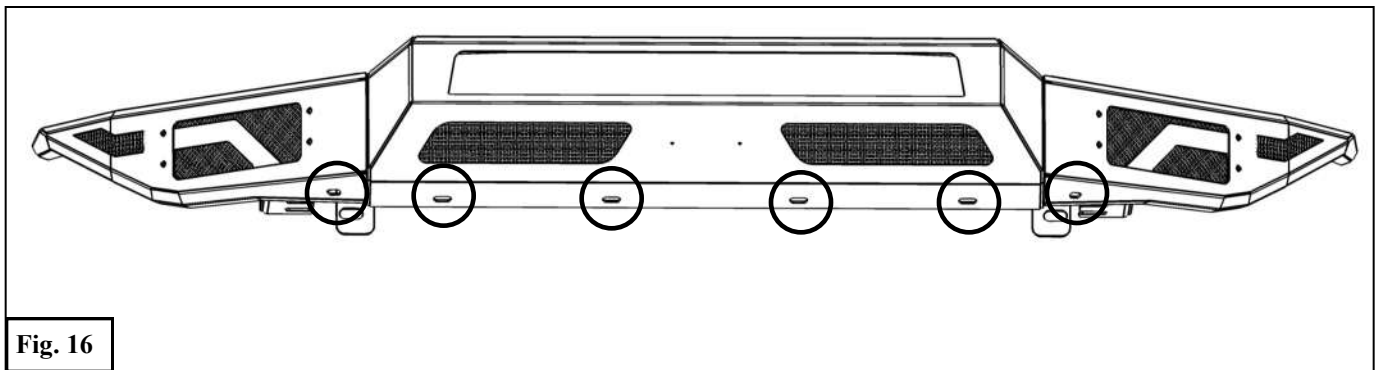



INSTALLATION COMPLETE



LED Lights and side pod light mounts sold separately

#### CARE INSTRUCTIONS

- REGULAR WAXING IS RECOMMENDED. DO NOT USE ANY TYPE OF POLISH OR WAX THAT MAY CONTAIN ABRASIVES.
- STAINLESS STEEL PRODUCTS CAN BE CLEANED WITH MILD SOAP AND WATER. STAINLESS STEEL POLISH SHOULD BE USED TO POLISH SMALL SCRATCHES.
- GLOSS BLACK FINISHES SHOULD BE CLEANED WITH MILD SOAP AND WATER

**WESTIN**



## WARNING



Failure to follow these instructions could lead to death, personal injury, and / or property damage.

Failure to follow these instructions could lead to death, personal injury, and / or property damage.

### FASTENERS:

All Westin supplied fasteners must be utilized and installed in accordance with the installation instructions and apply torque to the specifications as defined. **DOUBLE CHECK ALL FASTENERS BEFORE INITIAL USE, AND PERIODICALLY IN THE FUTURE TO ENSURE PROPER FUNCTION AND SAFETY.**

### DRILLING:

Most Westin products do not require drilling for installation. If drilling is defined as required, use caution when drilling a vehicle. **FAILURE TO REVIEW AN AREA TO BE DRILLED MAY RESULT IN PERSONAL INJURY AND/OR INJURY TO OTHERS AS WELL AS VEHICLE DAMAGE.**

### EYE PROTECTION:

**ALWAYS WEAR SAFETY GLASSES OR GOGGLES DURING THE INSTALLATION PROCESS TO AVOID PERSONAL INJURY.**

### MAXIMUM TOWING/CARRYING CAPACITY: (if applicable)

The Westin Receiver Hitches will have a visible tow rating label affixed directly on the product. User should never exceed the vehicle manufacturers maximum tow and weight rating regardless of the capacity of the hitch. **FAILURE TO FOLLOW THESE GUIDELINES WILL VOID THE WESTIN WARRANTY AND MAY RESULT IN PERSONAL INJURY AND/OR INJURY TO OTHERS AS WELL AS VEHICLE DAMAGE.**

### FOR CALIFORNIA RESIDENTS ONLY-PROP 65 WARNING:

Some products may contain chemicals such as DEHP, which can cause cancer, birth defects or other reproductive harm.

