

# INSTALLATION INSTRUCTIONS

## PROMOD FRONT BUMPER



**APPLICATION:**  
2015-2019 Chevrolet Colorado  
**PART NUMBER:**  
58-41055

CONTENT			
ITEM	QUANTITY	DESCRIPTION	TOOLS NEEDED
1	2	SIDE POD ASSEMBLY (1 DRIVER, 1 PASSENGER)	10MM SOCKET
2	2	MESH SIDE COVERS (1 DRIVER, 1 PASSENGER)	10MM WRENCH
3	1	CENTER SECTION	17MM SOCKET
4	2	LED LIGHT BRACKET	17MM WRENCH
5	1	DRIVER MOUNTING BRACKET	19MM SOCKET
6	1	PASSENGER MOUNTING BRACKET	19MM WRENCH
7	1	PASSENGER SUPPORT BRACKET	TORQUE WRENCH
8	1	DRIVER SUPPORT BRACKET	CUTTING TOOL
9	1	M10 BOLT PLATE	RATCHET
10	4	M12 HEX HEAD BOLT (YELLOW ZINC)	
11	4	M12 HEX NUT (YELLOW ZINC)	
12	8	M12 FLAT WASHER (YELLOW ZINC)	
13	4	M12 SPLIT LOCK WASHER (YELLOW ZINC)	
14	8	M10 SPLIT LOCK WASHER (YELLOW ZINC)	
15	12	M10 FLAT WASHER (YELLOW ZINC)	
16	8	M10 SERRATED FLANGE HEX HEAD BOLT (YELLOW ZINC)	
17	8	M10 HEX NUT (YELLOW ZINC)	
18	12	M6 FLAT WASHER (BLACK ZINC)	
19	12	M6 SPLIT LOCK WASHER (BLACK ZINC)	
20	12	M6 BUTTON HEAD BOLT (BLACK ZINC)	
21	12	M6 SERRATED FLANGE NUT (BLACK ZINC)	
22	4	M10 BUTTON HEAD BOLT (BLACK ZINC)	
23	8	M10 FLAT WASHER (BLACK ZINC)	
24	4	M10 SPLIT LOCK WASHER (BLACK ZINC)	

**ANTI-SEIZE LUBRICANT MUST BE USED ON ALL STAINLESS STEEL FASTENERS TO PREVENT THREAD DAMAGE AND GALLING**

### PROCEDURE

1. Remove contents from box, verify if all parts listed are present and free from damage.  
Carefully read and understand all instructions before attempting installation.  
**Failure to identify damage before installation could lead to a rejection of any claim.**



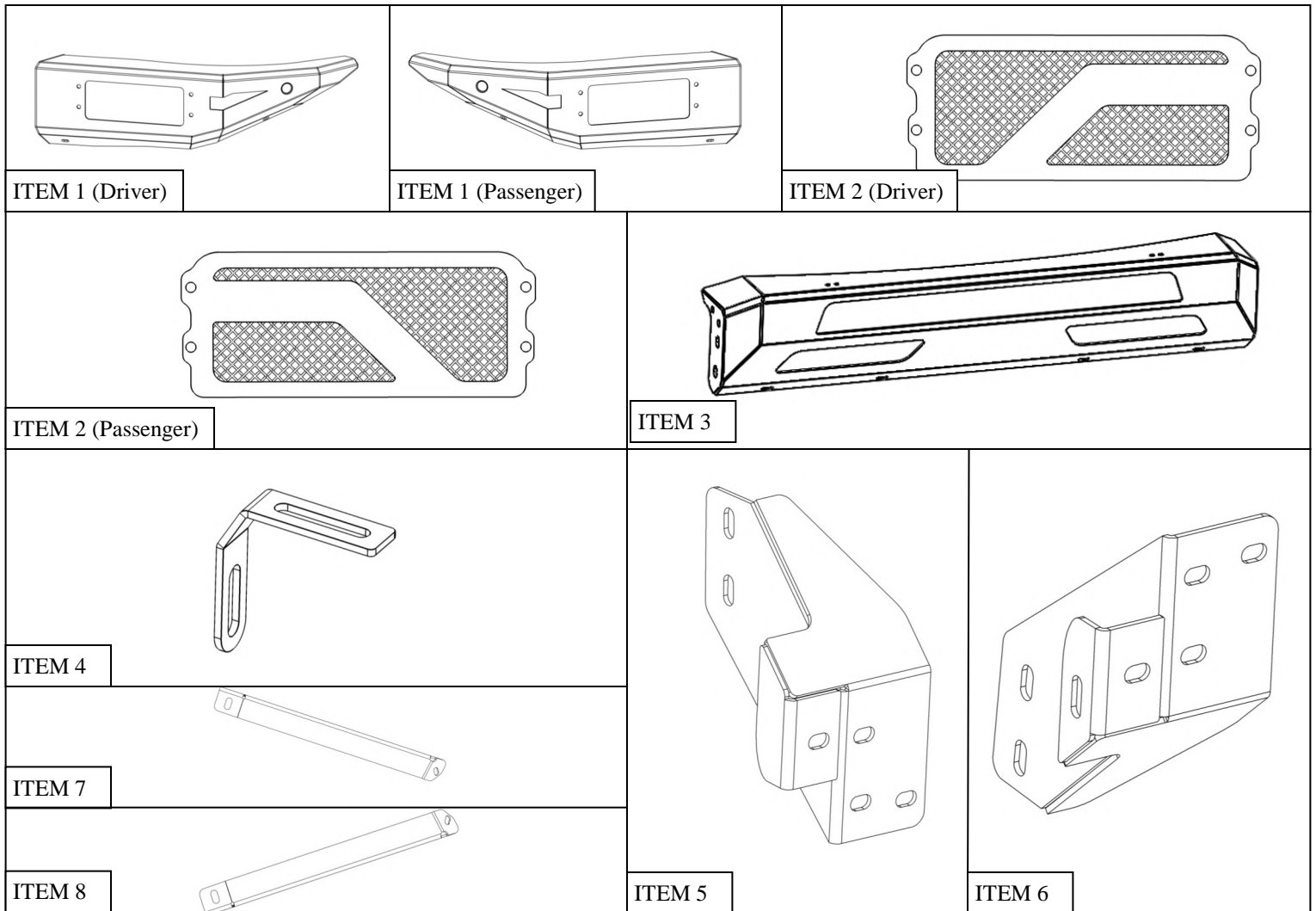

2. Remove the trim fasteners from the OEM fender liner. See **Figure 1**.
3. Disconnect any wire connections to the front bumper. See **Figure 2**.

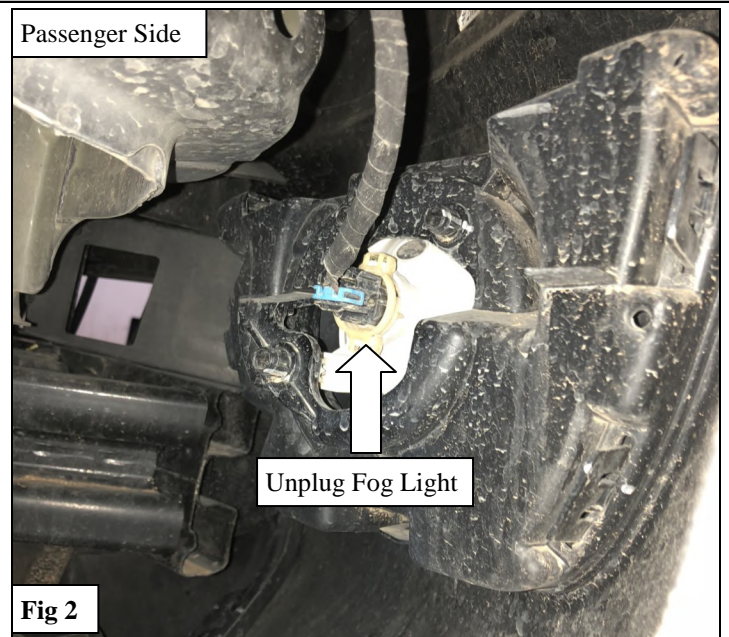
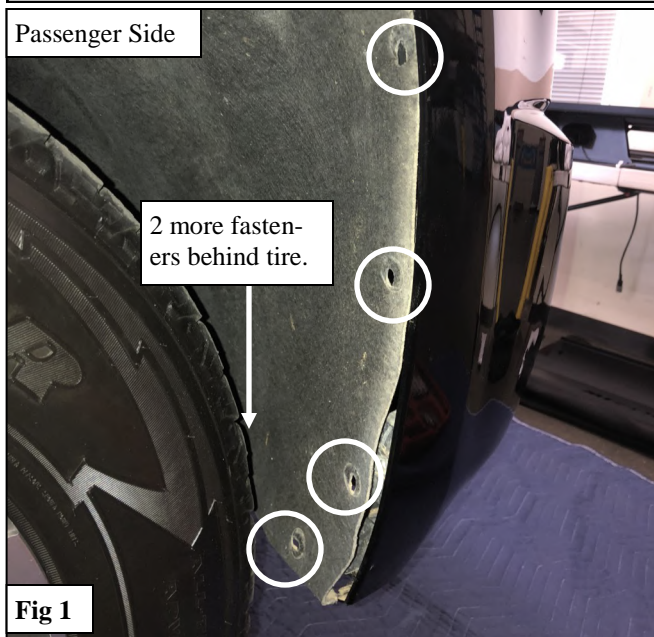

4. Remove the 3 bolts on each side behind the fender liner. See **Figure 3**.
5. Remove the 2 bolts on the front below the grille. See **Figure 4**.

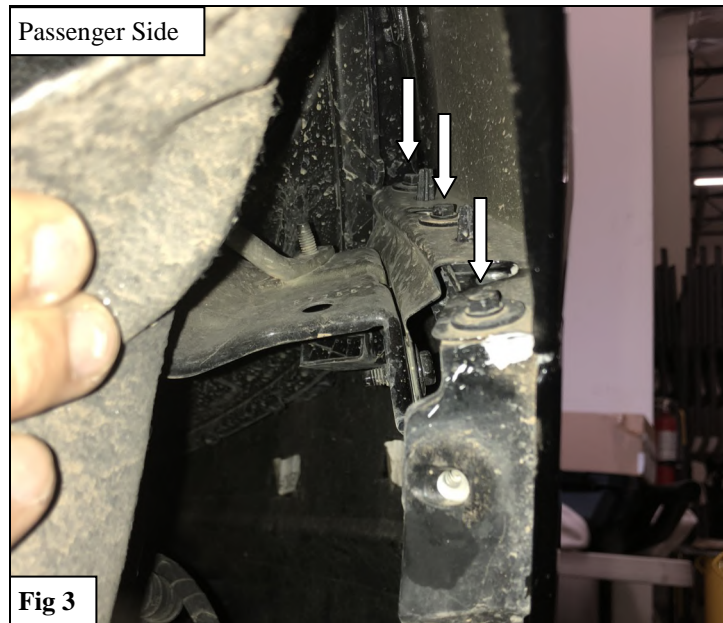

6. Open the hood and remove the 9 clips shown in **Figure 5**.
7. Remove the 6 bolts holding the grille to the vehicle. See **Figure 6**.

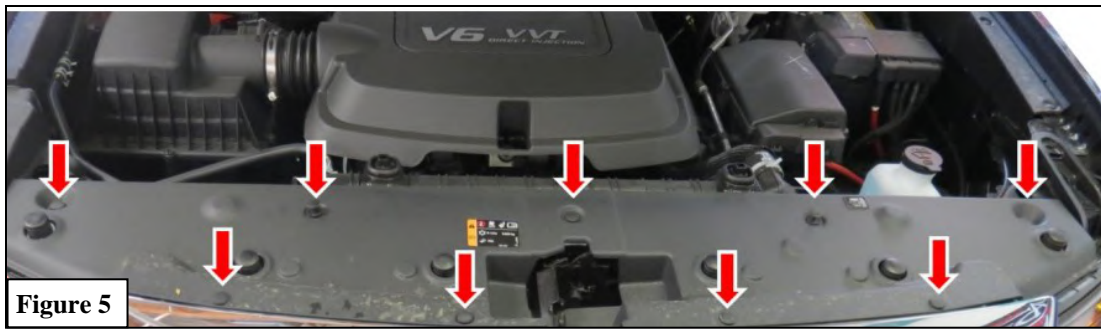

8. Gently pull the grille/bumper assembly to release it from the clips attaching it to the vehicle.
9. Remove the grille from the grille/bumper assembly. See **Figure 7**.
10. Remove the 2 bolts on either side that secure the reinforcement bar to the vehicle, and remove the bar. See **Figure 8**.

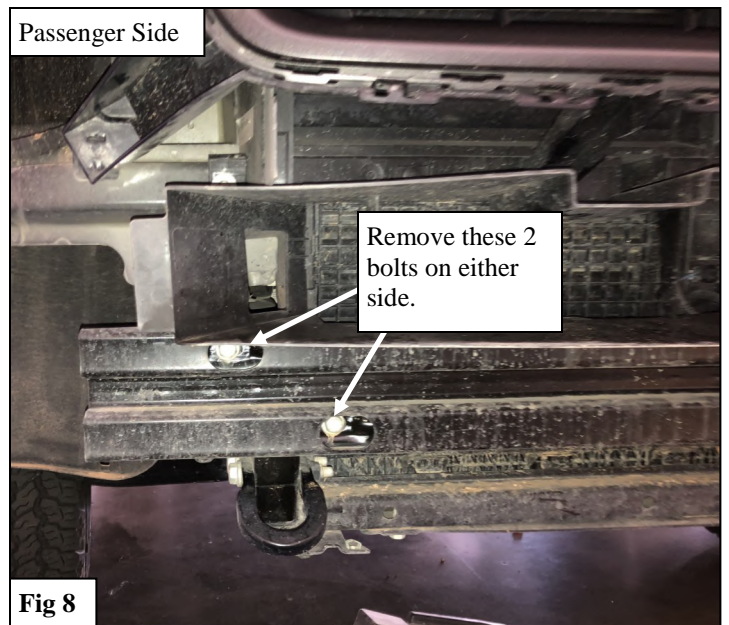
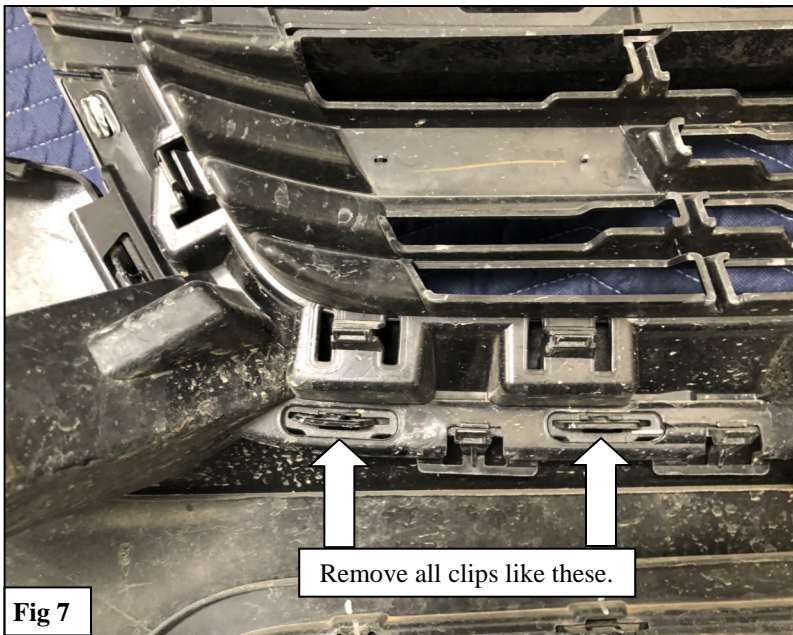

11. Remove the factory plate just below the tow hook on either side of the vehicle. See **Figure 9**.

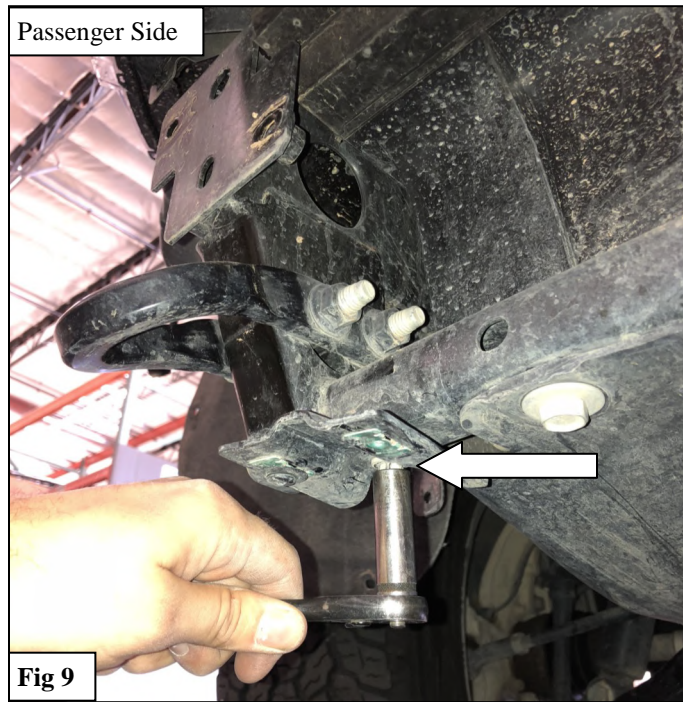

**TRIMMING NEEDED OR OPTIONAL ZR2 PANEL INSTALLATION**

- **Trimming of the factory bumper will be necessary to install the Pro Mod Front Bumper**
- **If you would not like to trim the bumper, the Colorado ZR2 part numbers 84119762 & 84119761 may be purchased separately and installed. These panels will also allow for the installation of the bumper.**
- **ONLY ONE OPTION IS NEEDED: YOU MAY EITHER TRIM THE OEM BUMPER OR PURCHASE THE ZR2 PANELS SEPARATELY**

**Optional ZR2 Panel Installation**

1. Remove the trim piece from the OEM Bumper and trim it as indicated in **Figure 10-12**.

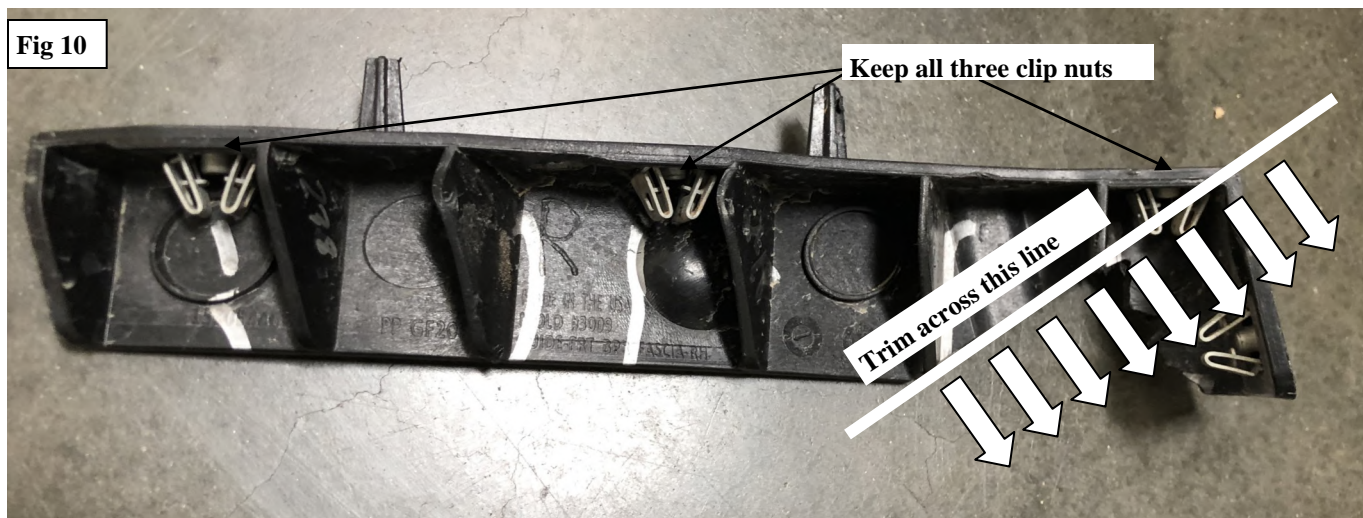

## TRIMMING PROCEDURE

Figure 11

Passenger Side



Figure 12



2. Reinstall the OEM Grille as removed in **Steps 6 & 7**.
3. Install the ZR2 Panel with the trim piece as removed in **Step 4** using the factory hardware.
4. The other end of the ZR2 Panel may be attached to the OEM Grille using zip ties if necessary . See **Figure 13**.

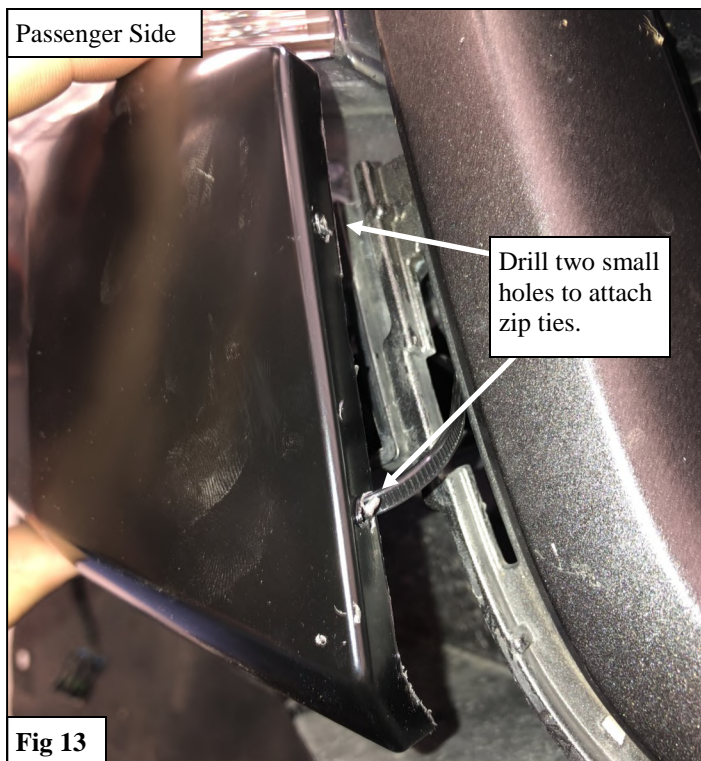

### **OEM Panel Trimming Process (only needed if not using ZR2 Panels)**

1. Refer to **Figure 14-16**. Trim the OEM Bumper using the supplied template as indicated. *Note: It is always better to trim a little at a time to ensure that too much material is not removed.*
2. Repeat this process for both sides.

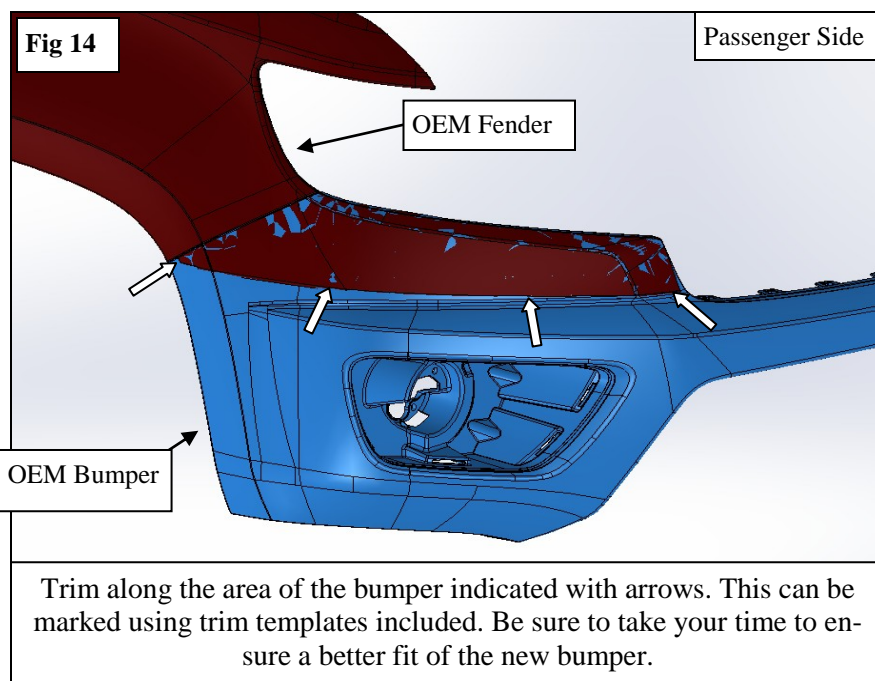

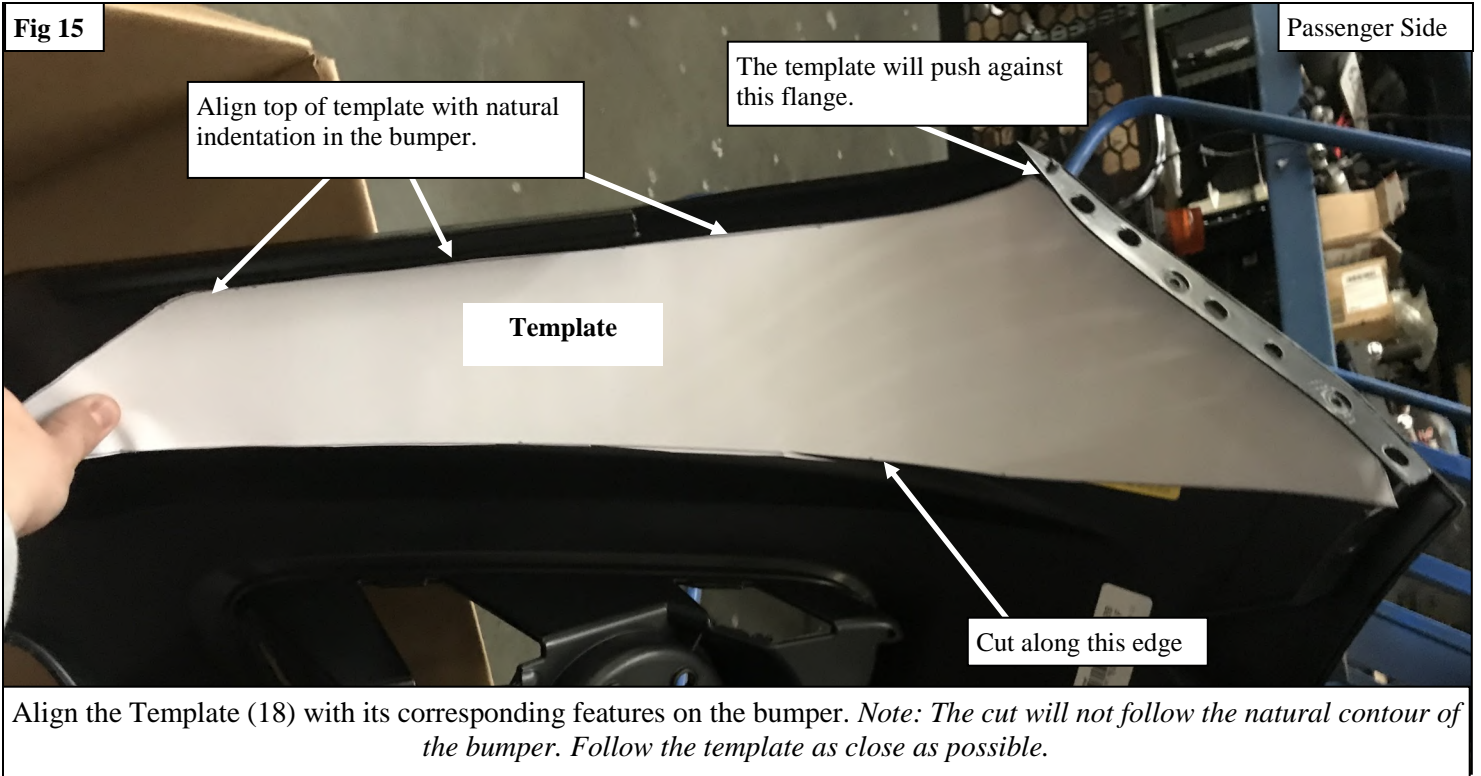



12. Loosely assemble the mounting brackets on to the front factory holes. Reuse the factory bumper bolts for these brackets.

**See Figure 17**

13. Install the M10 Bolt plates into the frame through the side. **See Figure 18-19**

**Fig. 17**

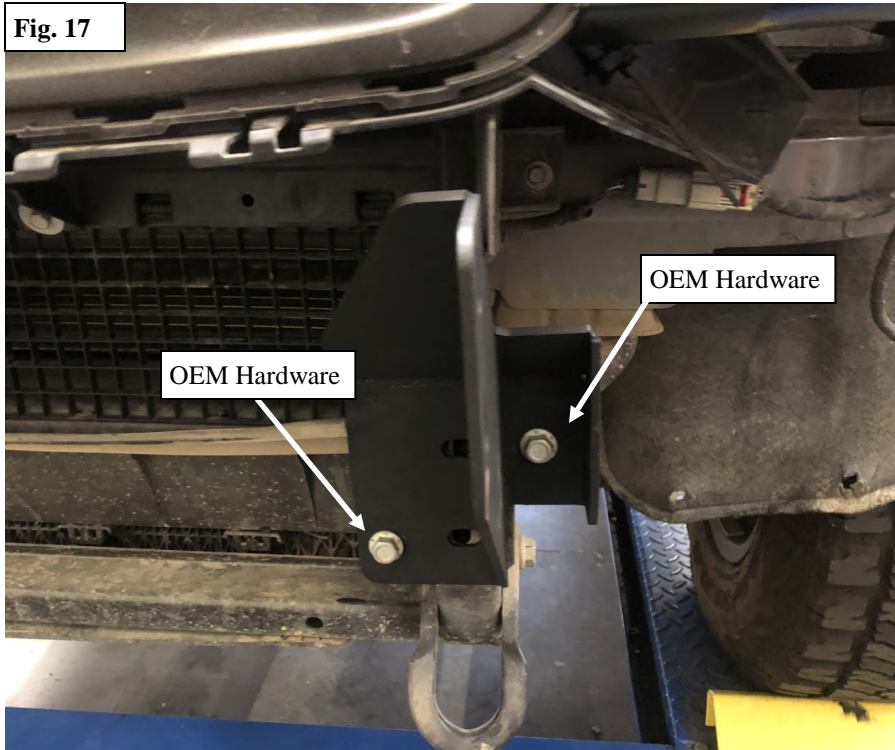

**Fig .18**



**Fig .19**

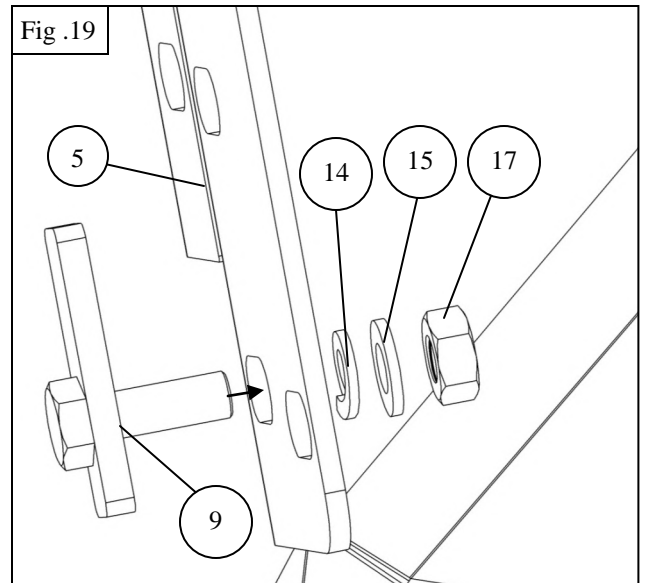

- 13. Use the supplied M10 Hardware to attach each Side Pod Assembly (1) to the Center Section (3). See **Figure 20**.
- 14. Tighten side pods in position now. Torque M10 hardware to 38 ft-lbs.
- 15. Use the supplied M6 Hardware to attach the LED Brackets (4) to the center section. See **Figure 21**. *Note: If installing an LED Light Bar (sold separately), install it at this time.*

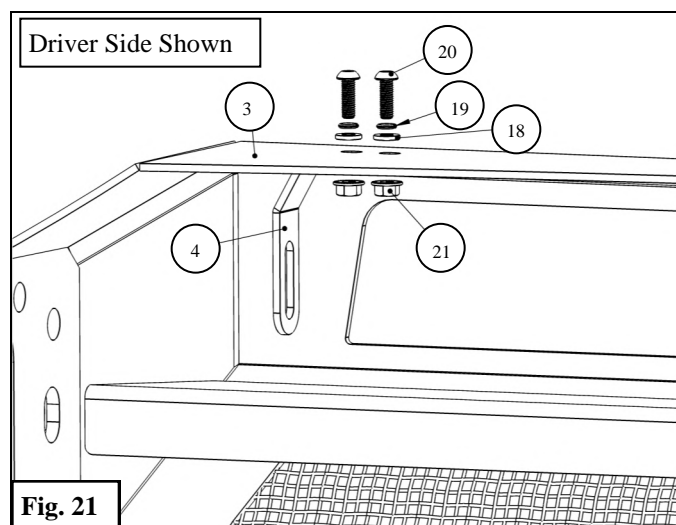
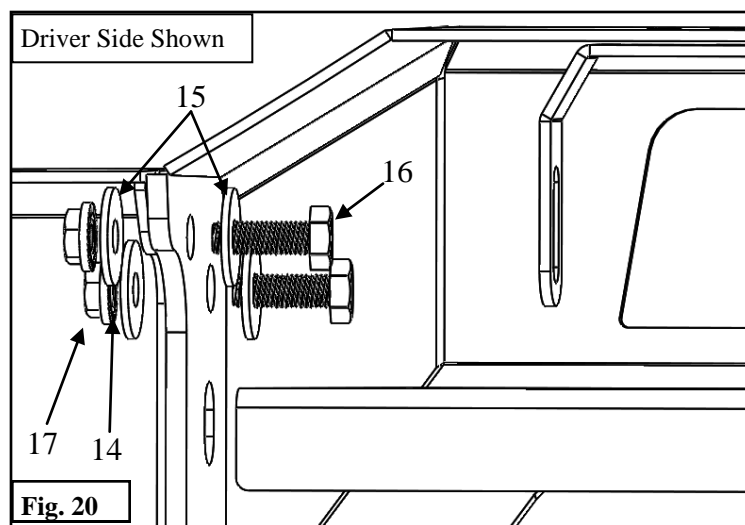

16. Loosely install the bumper assembly to the Mounting Brackets (5,6) using the supplied M12 Hardware. See **Figure 22**.

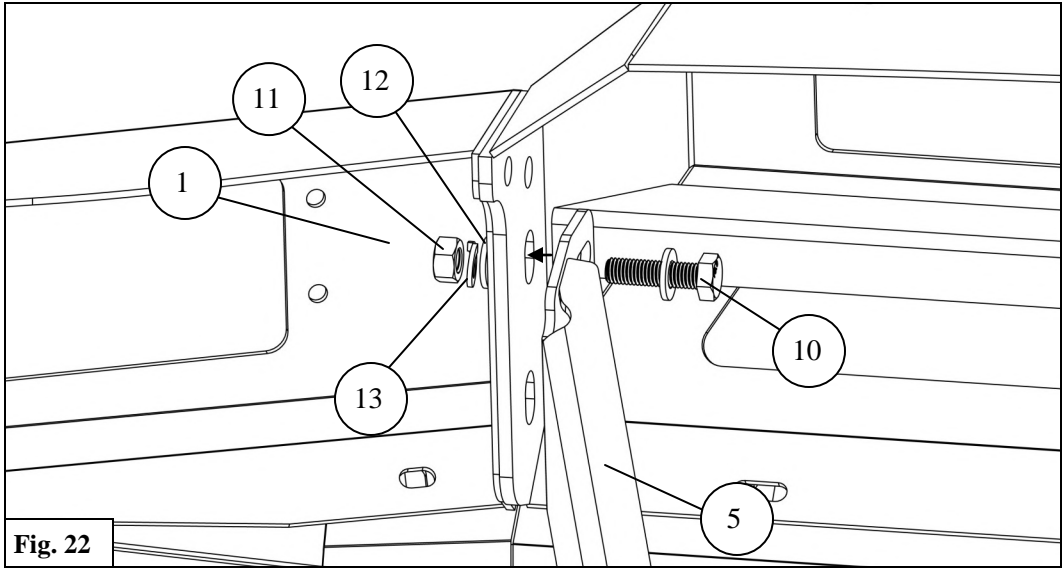

17. Loosely install the support bracket (8) using supplied M10 hardware (19, 24-26). See **Figure 23**

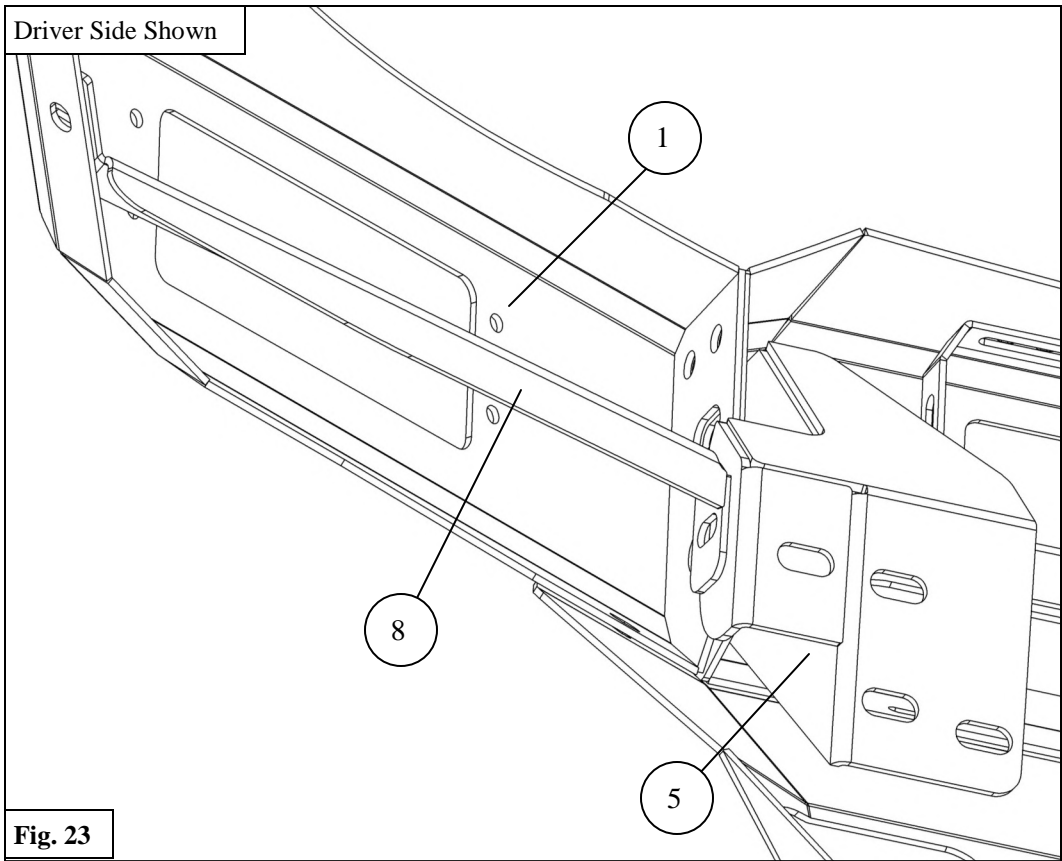

13. Attach the Mesh Side Covers (2) to the Bumper using the supplied M6 Hardware. See **Figures 24 & 25.**

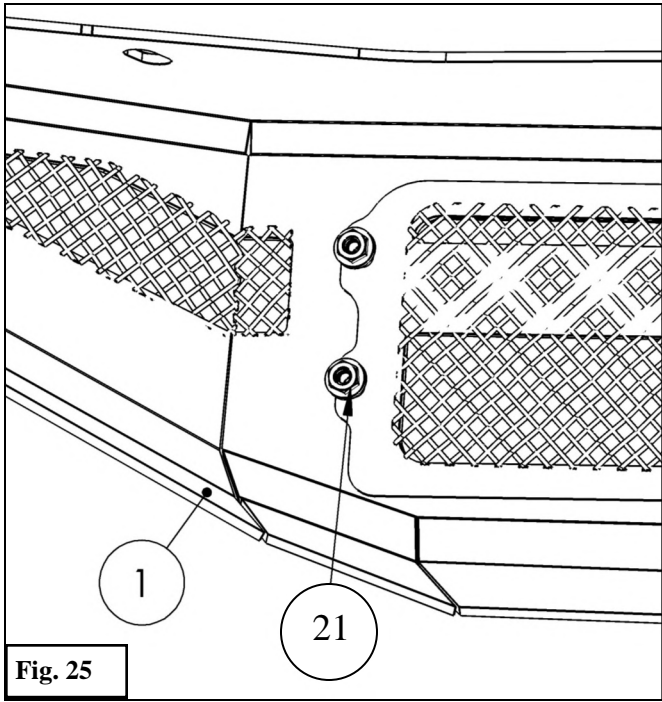
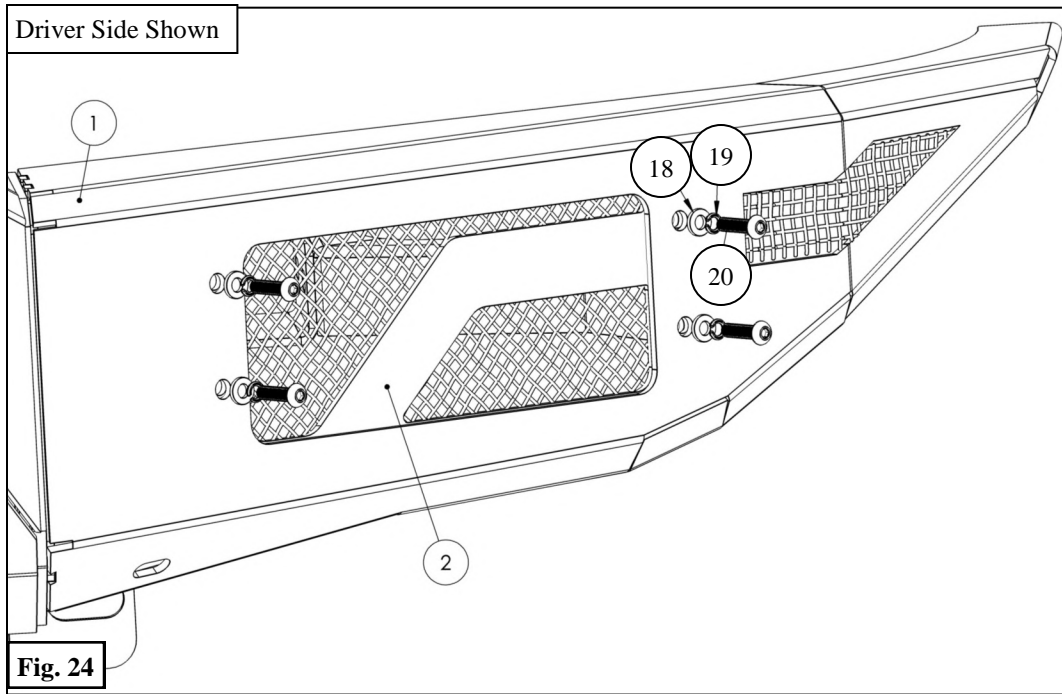

14. Align bumper as desired and torque all hardware as specified: M6 to 7 ft-lbs, M10 to 38 ft-lbs, M12 to 60 ft-lbs.

INSTALLATION COMPLETE



LED Lights, side pod light mounts, and skid plate sold separately

#### CARE INSTRUCTIONS

- REGULAR WAXING IS RECOMMENDED. DO NOT USE ANY TYPE OF POLISH OR WAX THAT MAY CONTAIN ABRASIVES.
- STAINLESS STEEL PRODUCTS CAN BE CLEANED WITH MILD SOAP AND WATER. STAINLESS STEEL POLISH SHOULD BE USED TO POLISH SMALL SCRATCHES.
- GLOSS BLACK FINISHES SHOULD BE CLEANED WITH MILD SOAP AND WATER.



## WARNING



Failure to follow these instructions could lead to death, personal injury, and / or property damage.

Failure to follow these instructions could lead to death, personal injury, and / or property damage.

### FASTENERS:

All Westin supplied fasteners must be utilized and installed in accordance with the installation instructions and apply torque to the specifications as defined. **DOUBLE CHECK ALL FASTENERS BEFORE INITIAL USE, AND PERIODICALLY IN THE FUTURE TO ENSURE PROPER FUNCTION AND SAFETY.**

### DRILLING:

Most Westin products do not require drilling for installation. If drilling is defined as required, use caution when drilling a vehicle. **FAILURE TO REVIEW AN AREA TO BE DRILLED MAY RESULT IN PERSONAL INJURY AND/OR INJURY TO OTHERS AS WELL AS VEHICLE DAMAGE.**

### EYE PROTECTION:

**ALWAYS WEAR SAFETY GLASSES OR GOGGLES DURING THE INSTALLATION PROCESS TO AVOID PERSONAL INJURY.**

### MAXIMUM TOWING/CARRYING CAPACITY: (if applicable)

The Westin Receiver Hitches will have a visible tow rating label affixed directly on the product. User should never exceed the vehicle manufacturers maximum tow and weight rating regardless of the capacity of the hitch. **FAILURE TO FOLLOW THESE GUIDELINES WILL VOID THE WESTIN WARRANTY AND MAY RESULT IN PERSONAL INJURY AND/OR INJURY TO OTHERS AS WELL AS VEHICLE DAMAGE.**

### FOR CALIFORNIA RESIDENTS ONLY-PROP 65 WARNING:

Some products may contain chemicals such as DEHP, which can cause cancer, birth defects or other reproductive harm.