

# INSTALLATION INSTRUCTIONS

## PRO MOD BUMPER



APPLICATION:  
2016-2019 Toyota Tacoma  
PART NUMBER:  
58-41045

CONTENT			
ITEM	QUANTITY	DESCRIPTION	TOOLS NEEDED
1	1	CENTER SECTION	10MM SOCKET
2	1	DRIVER SIDE POD	17MM SOCKET
3	1	PASSENGER SIDE POD	19MM SOCKET
4	1	DRIVER MOUNTING BRACKET	ALLEN WRENCH
5	1	PASSENGER MOUNTING BRACKET	CUTTING TOOL
6	1	DRIVER SUPPORT BRACKET	RULER
7	1	PASSENGER SUPPORT BRACKET	MARKER
8	2	LED LIGHT BRACKET	TAPE
9	12	M6 BUTTON HEAD BOLT (BLACK ZINC)	PRYING TOOL
10	24	M6 FLAT WASHER (BLACK ZINC)	RATCHET
11	12	M6 SERRATED FLANGE NUT (BLACK ZINC)	TORQUE WRENCH
12	12	M6 LOCK WASHER (BLACK ZINC)	
13	4	M10 BUTTON HEAD BOLT (BLACK ZINC)	
14	4	M10 SPLIT LOCK WASHER (BLACK ZINC)	
15	8	M10 FLAT WASHER (BLACK ZINC)	
16	4	M10 HEX NUT (BLACK ZINC)	
17	14	M12 FLAT WASHER (YELLOW ZINC)	
18	4	M10 SERRATED FLANGE NUT (YELLOW ZINC)	
19	8	M10 FLAT WASHER (YELLOW ZINC)	
20	4	M10 HEX HEAD BOLT (YELLOW ZINC)	
21	4	M12 SERRATED FLANGE NUT (YELLOW ZINC)	
22	4	M12 HEX BOLT (YELLOW ZINC)	
23	4	M12 LOCK WASHER (YELLOW ZINC)	
24	1	DRIVER MESH POD COVER	
25	1	PASSENGER MESH POD COVER	

**ANTI-SEIZE LUBRICANT MUST BE USED ON ALL STAINLESS STEEL FASTENERS TO PREVENT THREAD DAMAGE AND GALLING**

### PROCEDURE

1. Remove contents from box, verify if all parts listed are present and free from damage.  
Carefully read and understand all instructions before attempting installation.  
**Failure to identify damage before installation could lead to a rejection of any claim.**



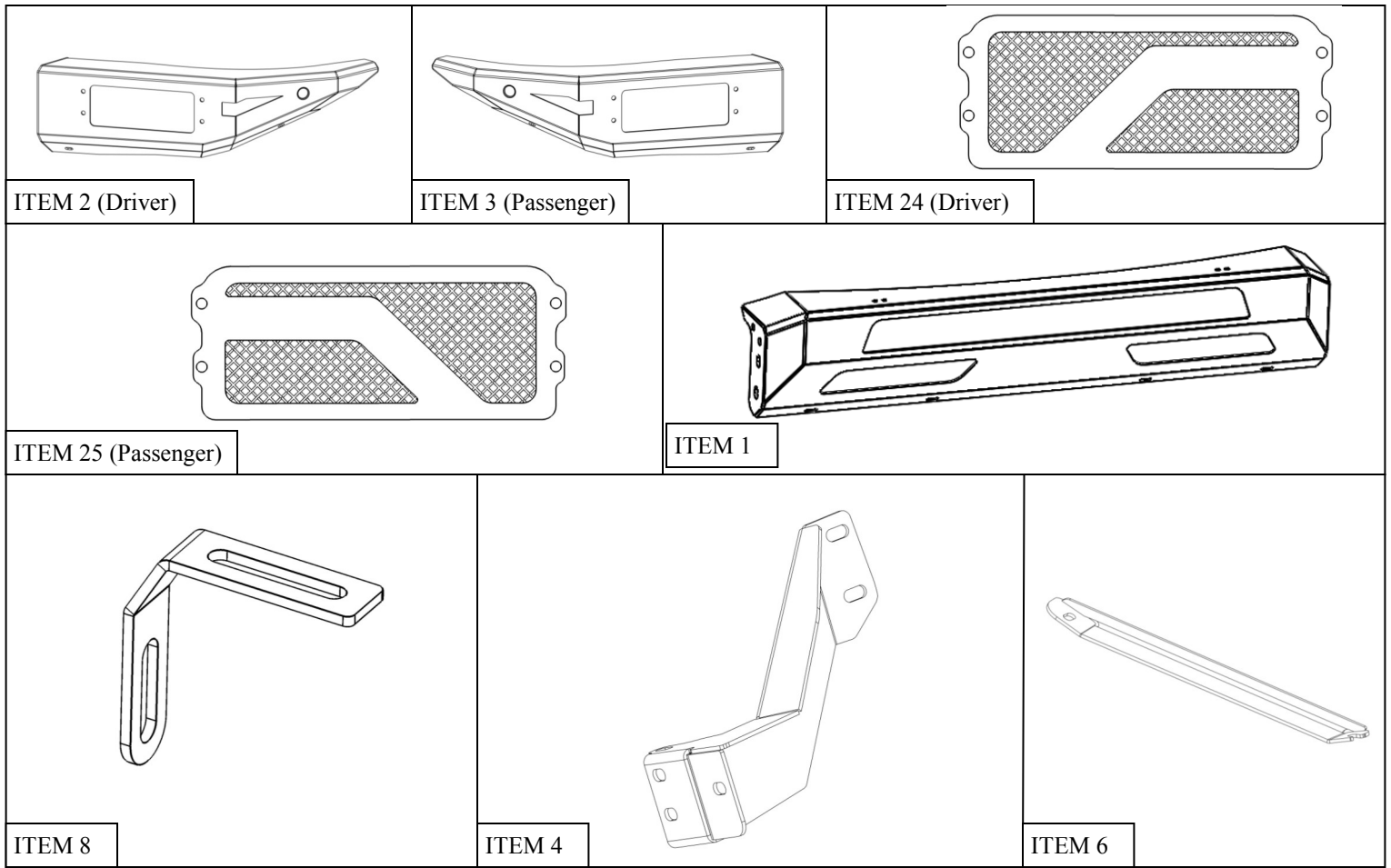

2. To remove front bumper, first remove the grill, fender flares and valance. To remove grill, remove two screws and push pins fastening it to the radiator area. See **Figure 1 and 2**. Once all fasteners have been removed, firmly pull radiator from top towards the front of the vehicle.

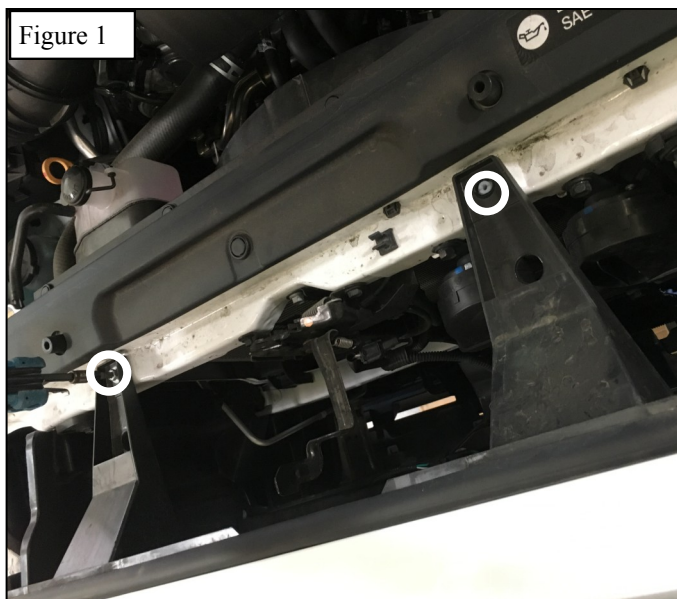

Figure 1



Figure 2

3. Next, remove fender flares by removing screws around the wheel well area; once all visible fasteners have been removed, firmly and carefully pull to unclip push pins. Save fender flares for later. They will be installed back and trimmed. See Figure 3

Figure 3



Figure 4

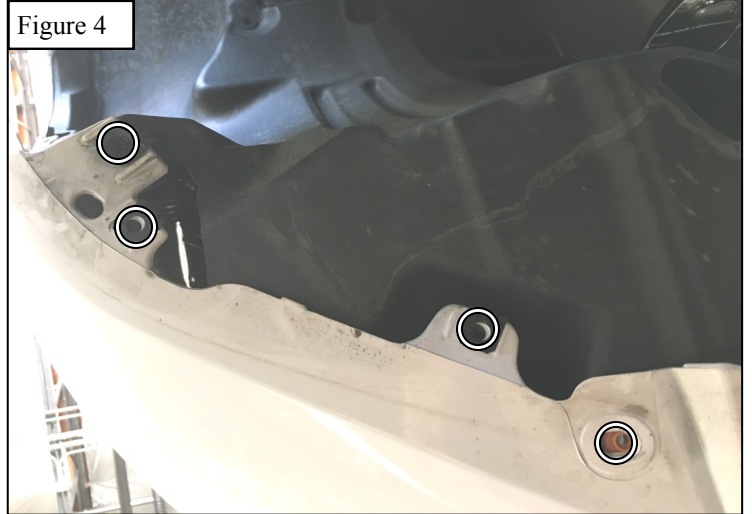

4. Remove valance by removing all fasteners holding it to the bottom of the bumper and wheel well liners. See Figures 4 and 5.

5. Remove all push pins fastening the bumper to the vehicle around the grille area and around head lights. Also, make sure to disconnect all wires and fog lights attached to the bumper.

Figure 5

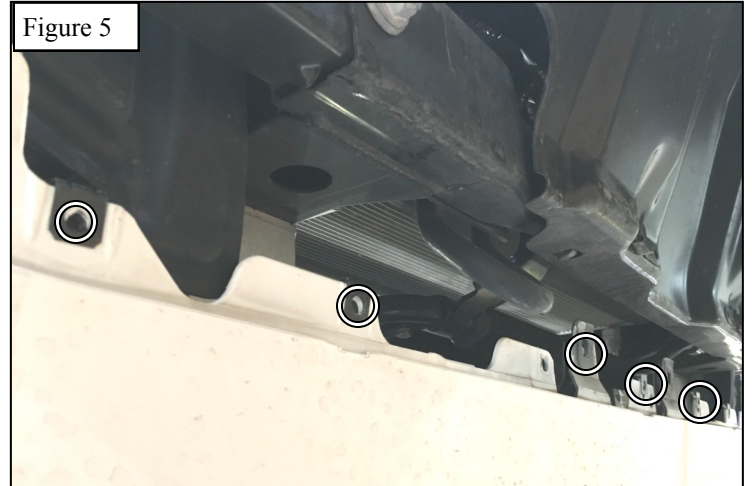
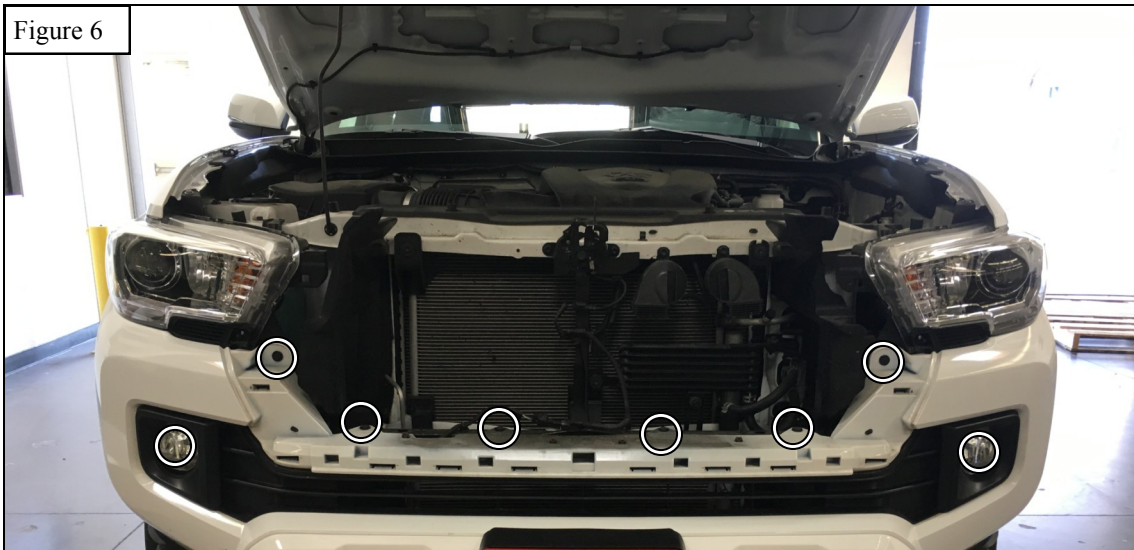

Figure 6



6. To remove bumper, it is recommended to seek assistance from a second person. Begin by pushing back wheel well plastic to expose a red push pin holding the bumper to a black plastic piece bolted to the metallic fender. See **Figure 7 and 8**.

Figure 7



Figure 8



7. Push red pin to allow black plastic piece to be separated from metallic fender See **Figure 8**, then using a pry tool, insert under tab to separate from bumper. Carefully separate the three tabs on each side of the truck. See **Figure 9**. When you completely detach one side, have someone hold the bumper for you to avoid damage on the other side. It is not necessary to unbolt black plastic piece from the fender. The bumper will be installed back again later after trimming.

Figure 9



8. Next, remove the aluminum bar attached to the frame of the vehicle using a 14MM socket or wrench. Remove by pulling firmly both sides at the same time. Save these nuts, they will be reused. See **Figure 10**.

Figure 10



### TRIMMING INSTRUCTIONS

9. Lay the OEM bumper assembly on a flat table. You will need a ruler, tape, and a marker.
- a. Starting at the driver side of the bumper. Measure from the top corner down 1.75". Mark a dash at that point. See **Figure 11-12**

Fig. 11

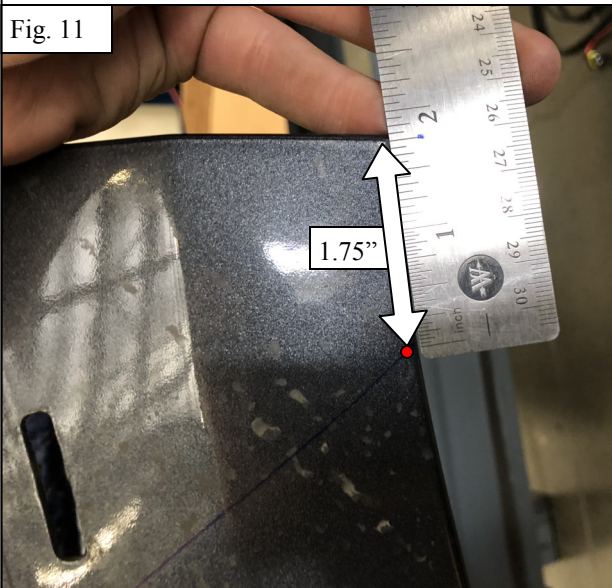
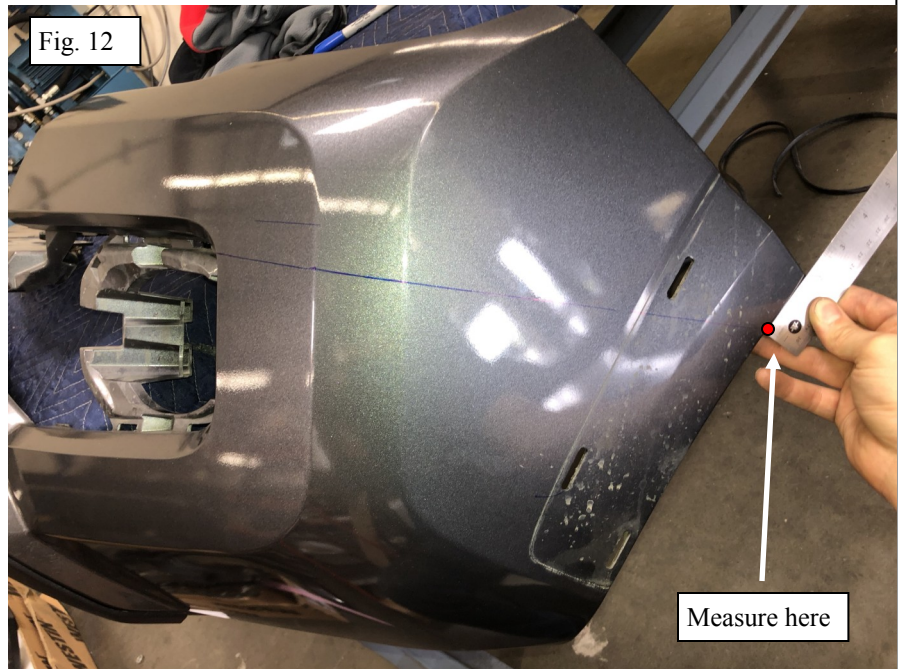
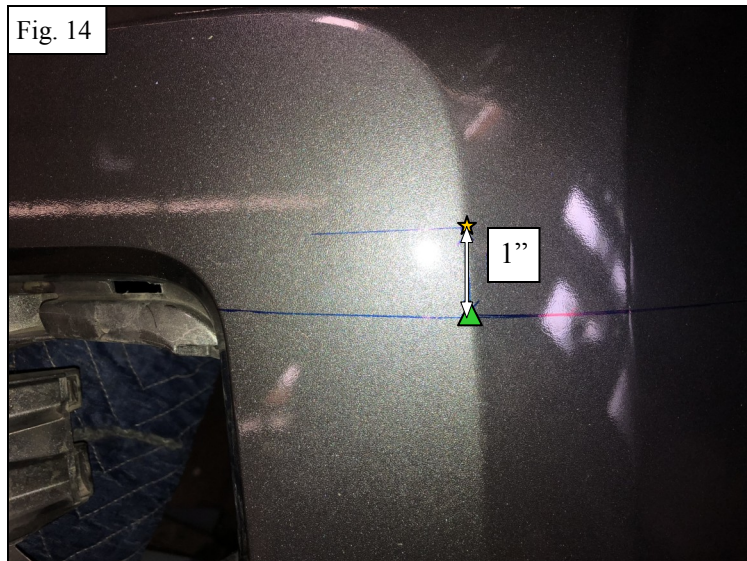
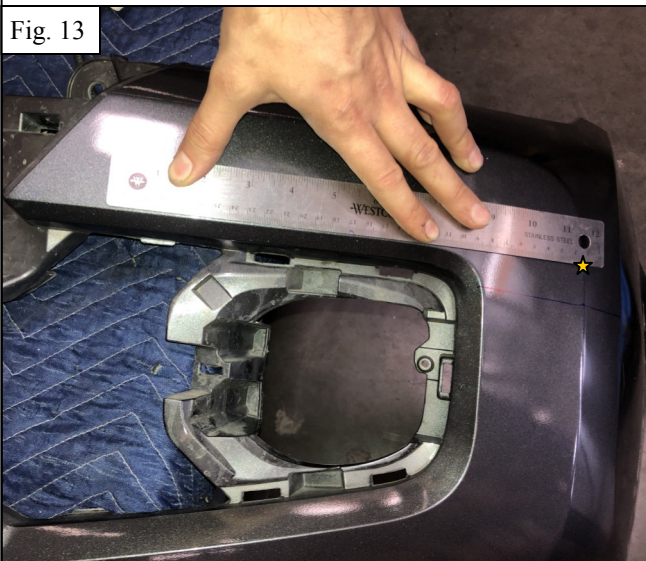

Fig. 12



**B.** Align a ruler with the edge of the bumper as shown in **Fig. 13**. Then, extend a line collinear to the edge of the bumper until it intersects the next edge on the bumper; mark a point on that intersection. Shown as a star on **Fig. 14**. Then, measure 1" down that star following the edge of the bumper and mark a point. Shown as a triangle.



- c. Using the ruler as a straightedge, connect the triangle to the dot as seen in **Figure 15**. Then extend the line towards the fog lamp pocket all the way to the end. This will be the trim line. But first, complete the next step to double check your line is correct.
- d. Measure from the intersection of your trim line and the edge of the fog lamp pocket to the upper edge of that bumper face. Verify that this measurement is 3.5". If it is not, then check your measurements and redraw the lines. If the measurement is correct, then you are ready to cut. **See Figure 15**

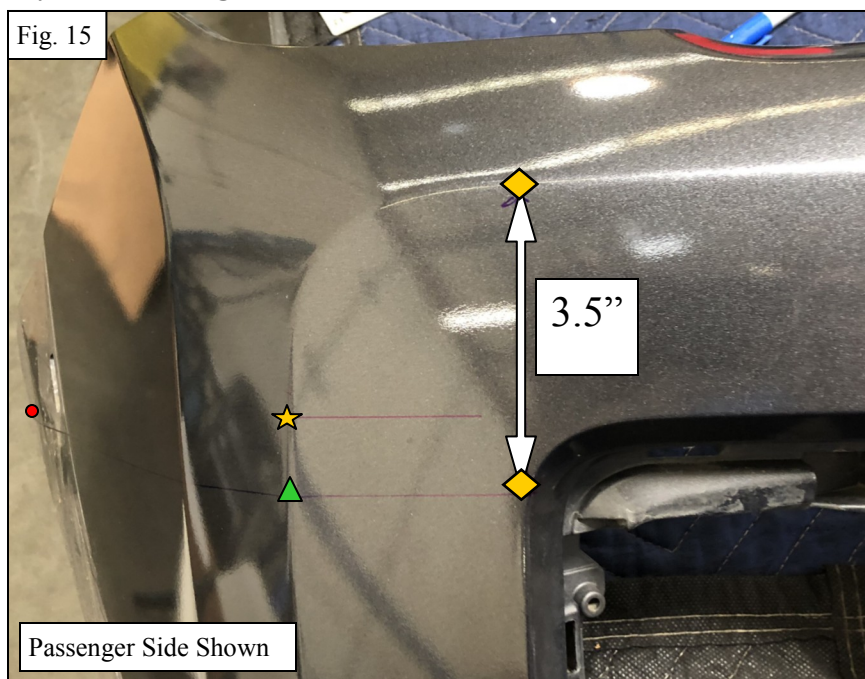

- e. Cut across the plastic as straight as possible, carefully using a very sharp knife or cutting tool.
- f. Repeat the process on the passenger side.
- g. Re-install the OEM bumper assembly and fender flares after trimming is complete. **See Figure 16 for example of trimmed bumper.**

Fig. 16



- h. Using the re-installed bumper as reference, lay a strip of tape parallel with the cut line on to the fender flare. Cut along this line. Repeat on passenger side. See Figure 17.

Fig. 17



- i. Trimming Procedure complete.

10. 9. Install items 4-5 to frame studs exposed on step 8. Install OEM nuts removed on step 8 but do not tighten. See **Figure 18**.

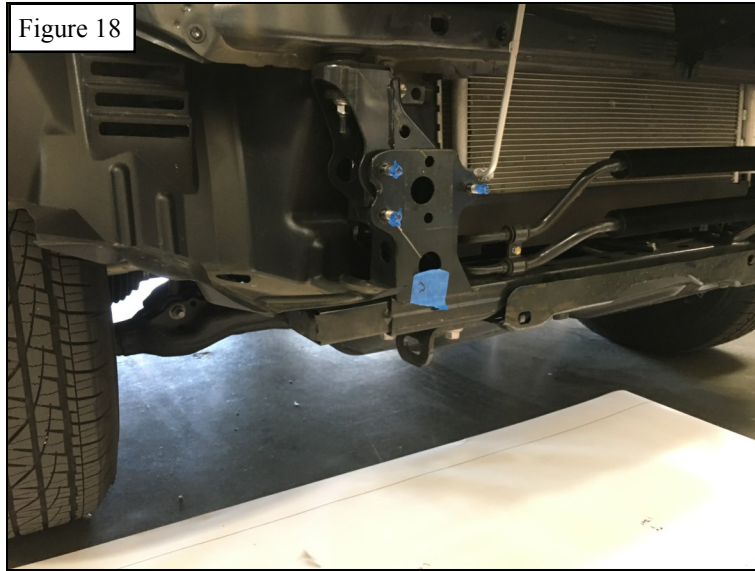

11. Loosely install the center section and side pods to the main brackets using the supplied M12 Hardware. See **Figure 19**.

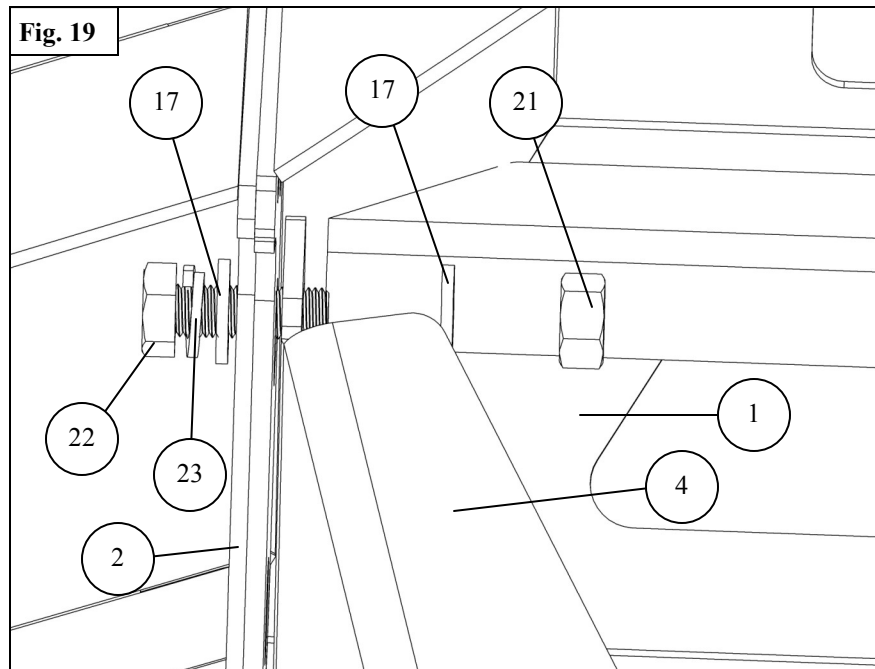



12. Loosely assemble the side support straps (6-7) on to the bumper using the supplied M10 hardware. See **Figure 20**.

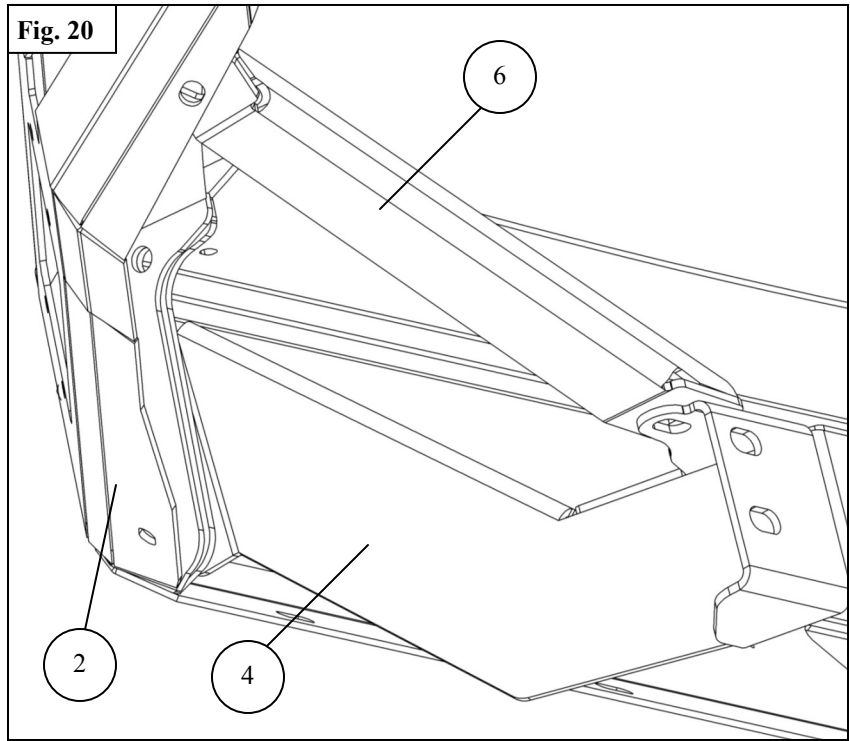

13. Attach the Mesh Side Covers (24-25) to the Bumper using the supplied M6 Hardware. See **Figures 21 & 22**.

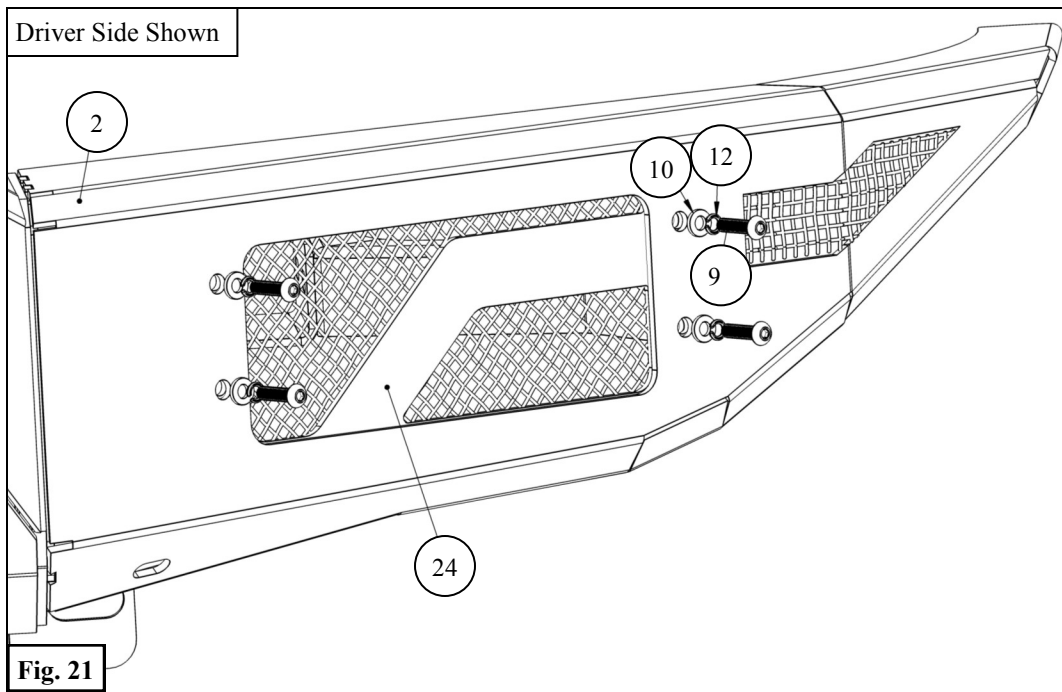

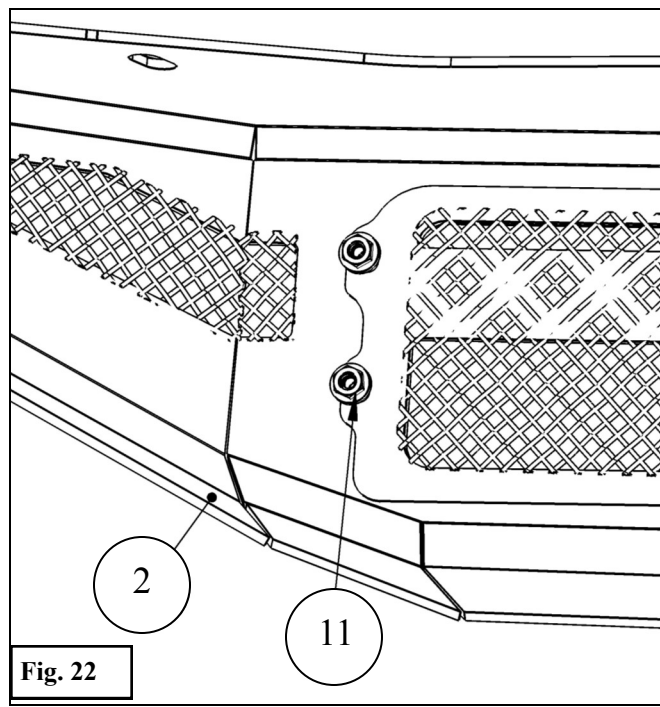

14. Align bumper as desired and torque all hardware as specified: M6 to 7 ft-lbs, M10 to 38 ft-lbs, M12 to 60 ft-lbs.

**INSTALL COMPLETE**



**CARE INSTRUCTIONS**

- REGULAR WAXING IS RECOMMENDED. DO NOT USE ANY TYPE OF POLISH OR WAX THAT MAY CONTAIN ABRASIVES.
- STAINLESS STEEL PRODUCTS CAN BE CLEANED WITH MILD SOAP AND WATER. STAINLESS STEEL POLISH SHOULD BE USED TO POLISH SMALL SCRATCHES.
- GLOSS BLACK FINISHES SHOULD BE CLEANED WITH MILD SOAP AND WATER.

**WESTIN**



## WARNING



Failure to follow these instructions could lead to death, personal injury, and / or property damage.

Failure to follow these instructions could lead to death, personal injury, and / or property damage.

### FASTENERS:

All Westin supplied fasteners must be utilized and installed in accordance with the installation instructions and apply torque to the specifications as defined. **DOUBLE CHECK ALL FASTENERS BEFORE INITIAL USE, AND PERIODICALLY IN THE FUTURE TO ENSURE PROPER FUNCTION AND SAFETY.**

### DRILLING:

Most Westin products do not require drilling for installation. If drilling is defined as required, use caution when drilling a vehicle. **FAILURE TO REVIEW AN AREA TO BE DRILLED MAY RESULT IN PERSONAL INJURY AND/OR INJURY TO OTHERS AS WELL AS VEHICLE DAMAGE.**

### EYE PROTECTION:

**ALWAYS WEAR SAFETY GLASSES OR GOGGLES DURING THE INSTALLATION PROCESS TO AVOID PERSONAL INJURY.**

### MAXIMUM TOWING/CARRYING CAPACITY: (if applicable)

The Westin Receiver Hitches will have a visible tow rating label affixed directly on the product. User should never exceed the vehicle manufacturers maximum tow and weight rating regardless of the capacity of the hitch. **FAILURE TO FOLLOW THESE GUIDELINES WILL VOID THE WESTIN WARRANTY AND MAY RESULT IN PERSONAL INJURY AND/OR INJURY TO OTHERS AS WELL AS VEHICLE DAMAGE.**

### FOR CALIFORNIA RESIDENTS ONLY-PROP 65 WARNING:

Some products may contain chemicals such as DEHP, which can cause cancer, birth defects or other reproductive harm.



Learn more about off-road bumpers we have.