

# INSTALLATION INSTRUCTIONS

## PRO-MOD BUMPER



**APPLICATION:**  
2016-2018 Chevrolet 1500; 2019 Silverado LD  
**PART NUMBER:**  
58-41005

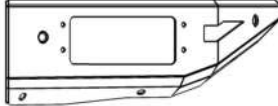
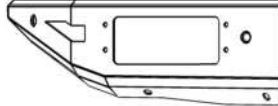
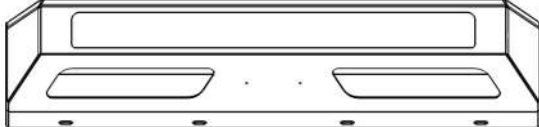

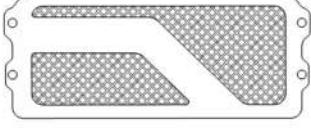
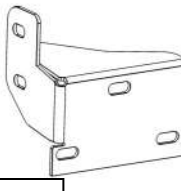
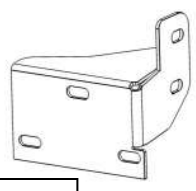
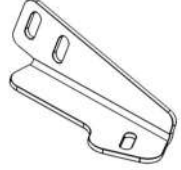
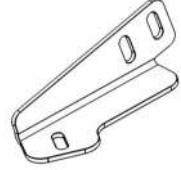


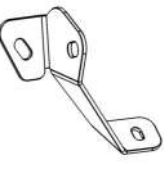
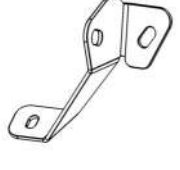
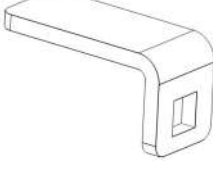
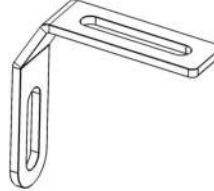
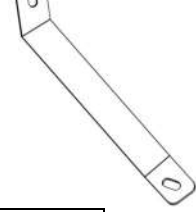
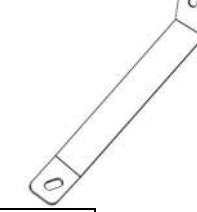
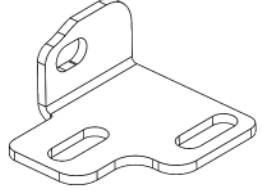
<b>CONTENT</b>			
<b>ITEM</b>	<b>QUANTITY</b>	<b>DESCRIPTION</b>	<b>TOOLS NEEDED</b>
1	1	DRIVER POD ASSEMBLY	10MM SOCKET
2	1	PASSENGER POD ASSEMBLY	10MM WRENCH
3	1	CENTER SECTION	13MM SOCKET
4	1	SKID PLATE	13MM WRENCH
5	2	MESH SIDE COVERS	16MM SOCKET
6	1	DRIVER MOUNTING BRACKET	16MM WRENCH
7	1	PASSENGER MOUNTING BRACKET	18MM SOCKET
8	1	DRIVER L-SUPPORT BRACKET	19MM WRENCH
9	1	PASSENGER L-SUPPORT BRACKET	ALLEN WRENCH
10	1	DRIVER SIDE STRAP	RATCHET
11	1	PASSENGER SIDE STRAP	TORQUE WRENCH
12	1	DRIVER VALANCE MOUNTING BRACKET	
13	1	PASSENGER VALANCE MOUNTING BRACKET	
14	4	SENSOR TAB	
15	2	LED BRACKET	
16	1	DRIVER OUTER SUPPORT STRAP	
17	1	PASSENGER OUTER SUPPORT STRAP	
18	1	DRIVER OPTIONAL SKID PLATE BRACKET	
19	1	PASSENGER OPTIONAL SKID PLATE BRACKET	
20	4	HOLE PLUG	
21	12	M6 BUTTON HEAD BOLT (BLACK ZINC)	
22	16	M6 FLAT WASHER (BLACK ZINC)	
23	12	M6 SERRATED FLANGE NUT (BLACK ZINC)	
24	16	M6 LOCK WASHER (BLACK ZINC)	
25	20	M8 FLAT WASHER (BLACK ZINC)	
26	12	M8 LOCK WASHER (BLACK ZINC)	
27	8	M8 SERRATED FLANGE NUT (BLACK ZINC)	
28	4	M12 SERRATED FLANGE NUT (BLACK ZINC)	
29	4	M12 HEX HEAD BOLT (BLACK ZINC)	

**ANTI-SEIZE LUBRICANT MUST BE USED ON ALL STAINLESS STEEL FASTENERS TO PREVENT THREAD DAMAGE AND GALLING**



ITEM	QUANTITY	DESCRIPTION	TOOLS NEEDED
30	4	M12 LOCK WASHER (BLACK ZINC)	
31	4	M12 FLAT WASHER (BLACK ZINC)	
32	12	M8 BUTTON HEAD BOLT (BLACK ZINC)	
33	4	M6 CARRIAGE BOLT (BLACK ZINC)	
34	4	M6 HEX NUT (BLACK ZINC)	
35	10	M10 BUTTON HEAD BOLT (BLACK ZINC)	
36	10	M10 FLAT WASHER (BLACK ZINC)	
37	10	M10 SERRATED FLANGE NUT (BLACK ZINC)	
38	4	M8 U-CLIP (YELLOW ZINC)	
39	4	M10 FLAT WASHER (YELLOW ZINC)	
40	4	M10 SERRATED FLANGE NUT (YELLOW ZINC)	
41	4	M10 HEX HEAD BOLT (YELLOW ZINC)	

**ANTI-SEIZE LUBRICANT MUST BE USED ON ALL STAINLESS STEEL FASTENERS TO PREVENT THREAD DAMAGE AND GALLING**

											
ITEM 1		ITEM 2		ITEM 3							
											
ITEM 4			ITEM 5		ITEM 6		ITEM 7				
											
ITEM 8		ITEM 9		ITEM 10		ITEM 11		ITEM 12		ITEM 13	
											
ITEM 14		ITEM 15		ITEM 16		ITEM 17		ITEM 18			

## PROCEDURE

1. Remove contents from box, verify if all parts listed are present and free from damage.  
Carefully read and understand all instructions before attempting installation.  
**Failure to identify damage before installation could lead to a rejection of any claim.**



Fig. 1

2. Remove stock bumper
  - a. Open the hood of the vehicle and remove the plastic cover at the front using a pry tool. See **Figure 1**.
  - b. Remove the four bolts holding the grill in place and uninstall the grill. See **Figure 2**.
  - c. Remove the braces on each side of the vehicle by removing the bolts indicated in **Figure 3**.
  - d. Disconnect all electrical connections to the stock bumper.
  - e. Remove the two bolts indicated in **Figure 4** on the driver's side of the vehicle. Repeat procedure on the passenger's side.
  - f. Remove stock bumper. See **Figure 5**.



Fig. 2

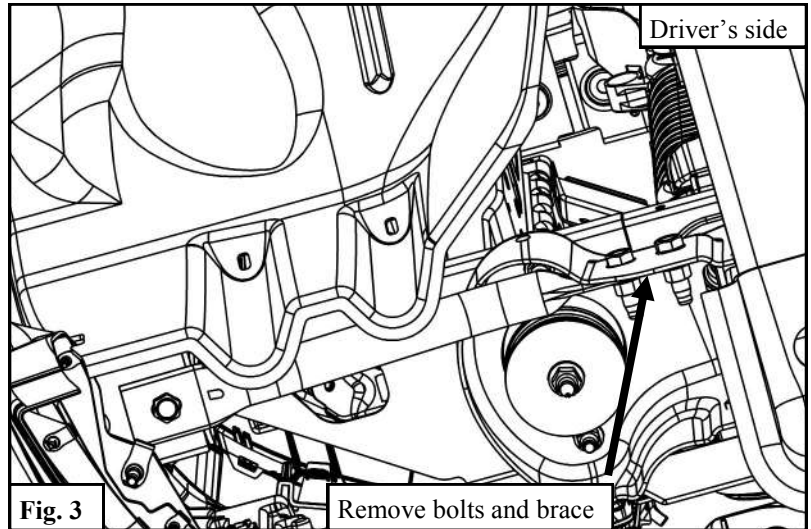


Fig. 3

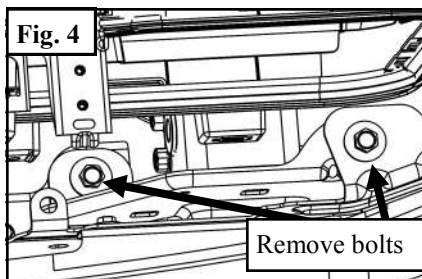


Fig. 4

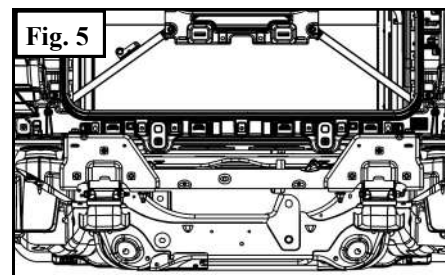
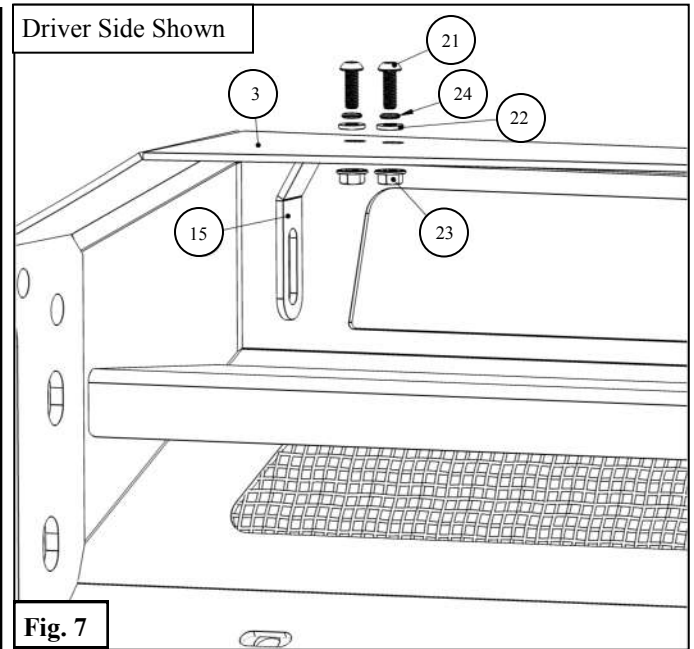
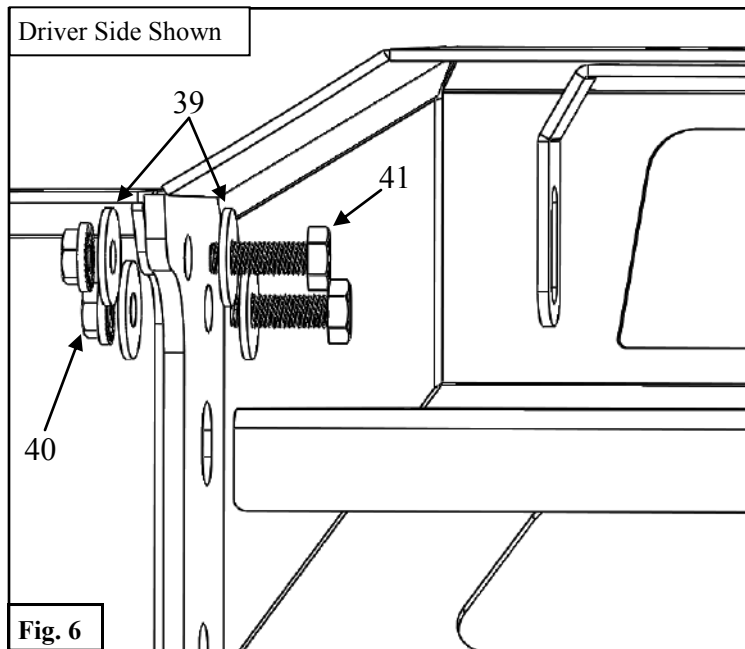
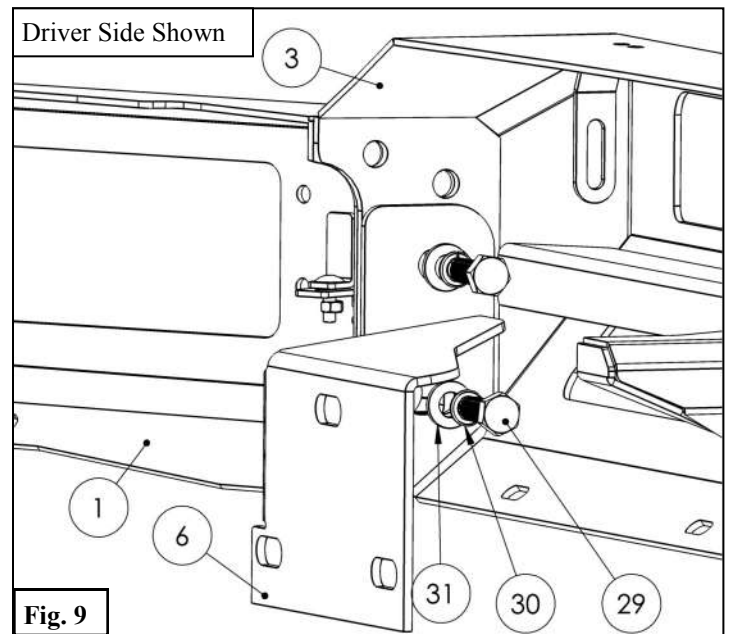
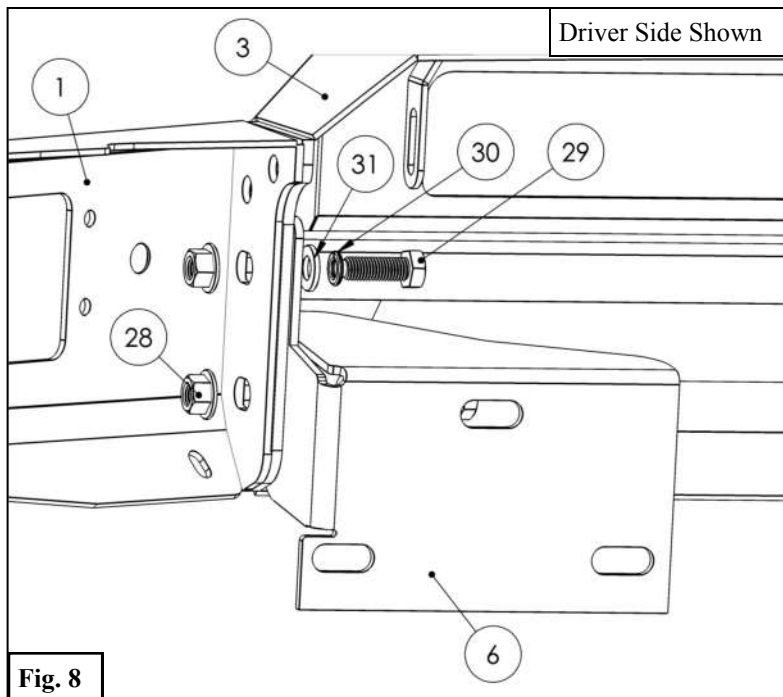


Fig. 5

3. Use the supplied M10 Hardware to attach each Side Pod Assembly (1,2) to the Center Section (3). See **Figure 6**.
4. Use the supplied M6 Hardware to attach the LED Brackets (15) to the center section. See **Figure 7**. *Note: If installing an LED Light Bar (sold separately), install it at this time.*



5. Loosely install the bumper assembly to the Mounting Brackets (6,7) using the supplied M12 Hardware. See **Figures 8 & 9**.

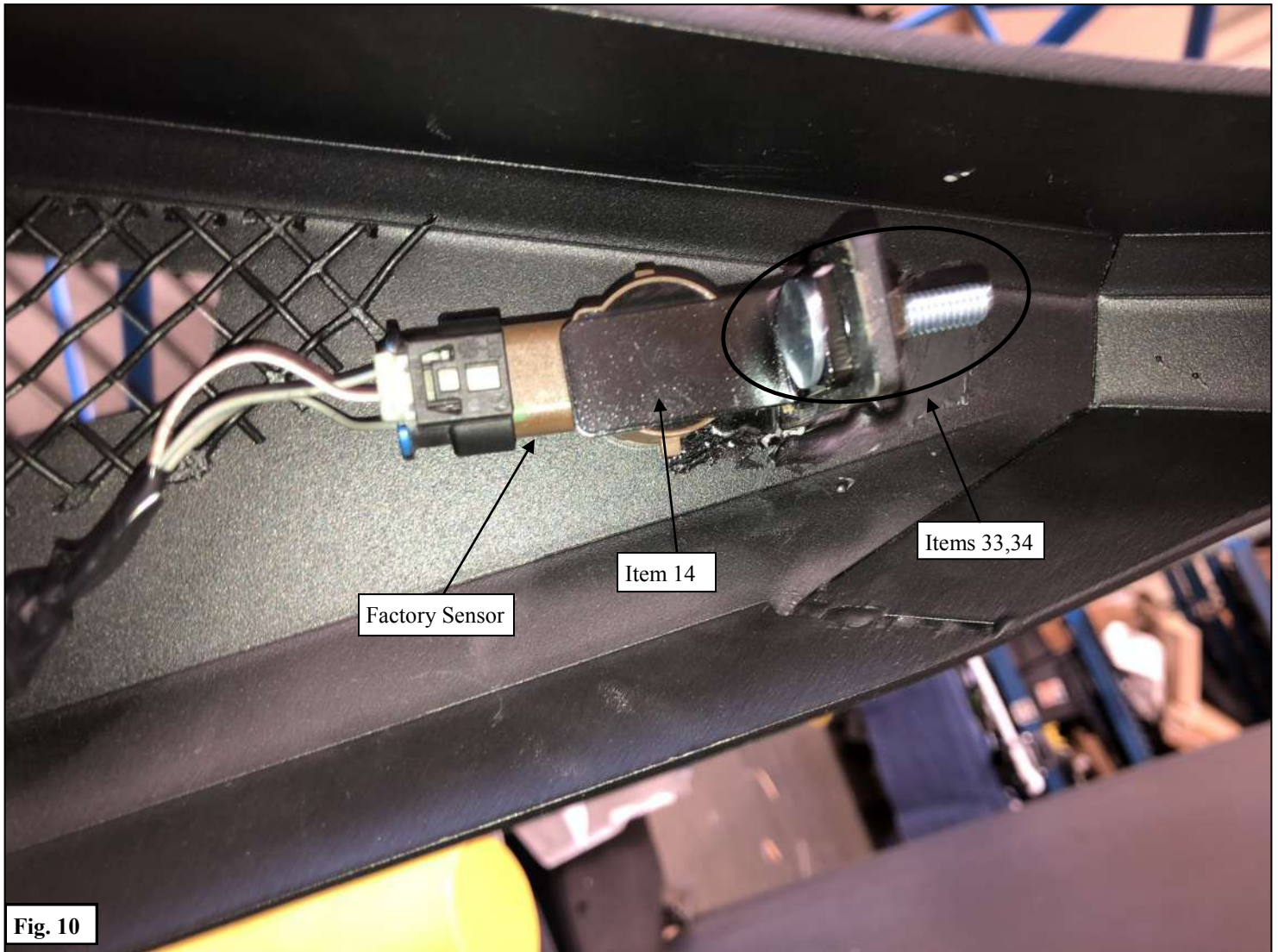




## PARKING SENSOR INSTALLATION

**\*If not installing sensors, install Hole Plugs (20) into holes on bumper and proceed**

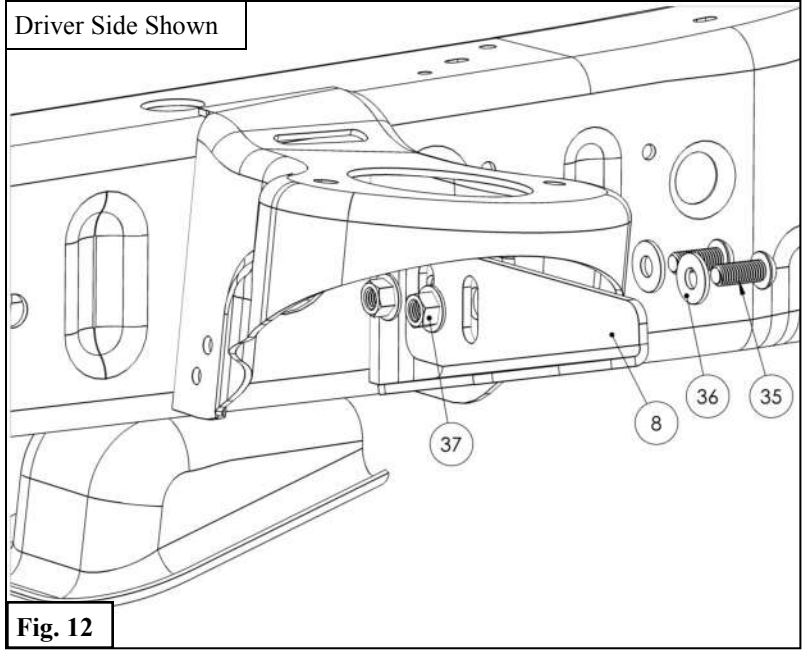
6. Remove the parking sensors from the OEM bumper.
7. Use the Sensor Tab (14) along with the supplied M6 Hardware (33,34) to install the sensors as shown in **Figure 10**.
8. Make sure to maintain stock sensor orientation.
9. Handle sensors with care as they are fragile.



- Loosely attach the preassembled bumper to the vehicle frame using the Factory Hardware. See **Figure 11**.
- Loosely attach the L-Support Brackets (8,9) to the vehicle's frame. See **Figure 12**.

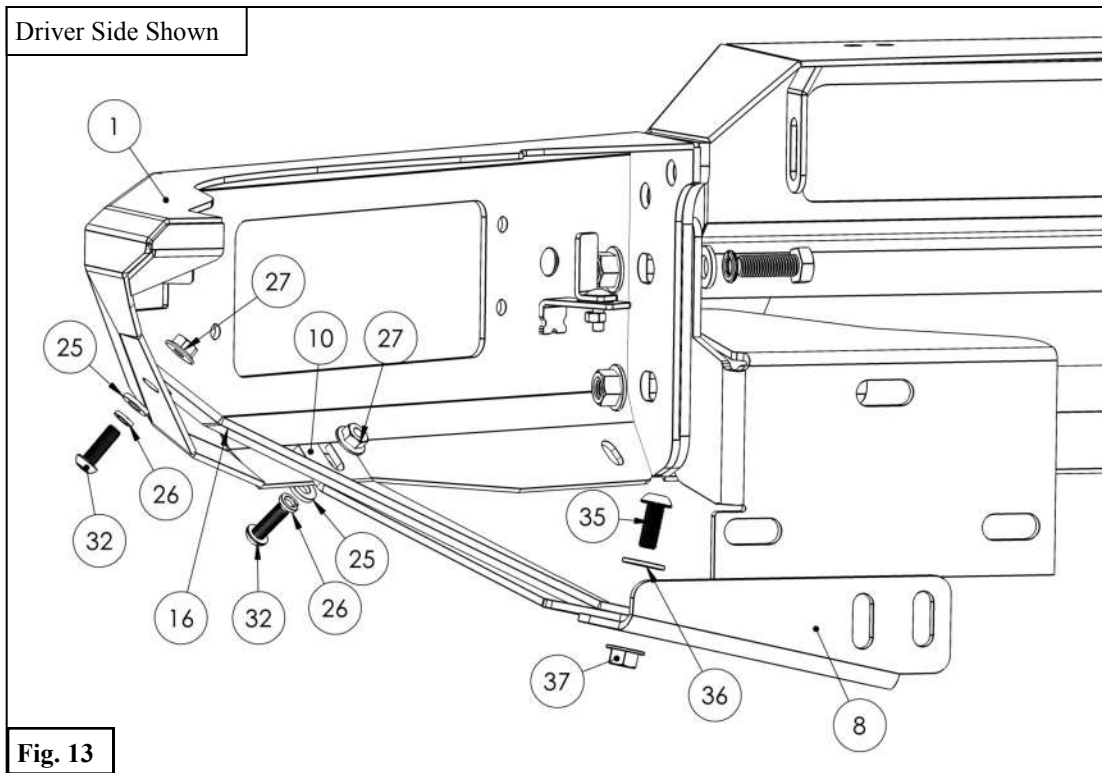


**Fig. 11**



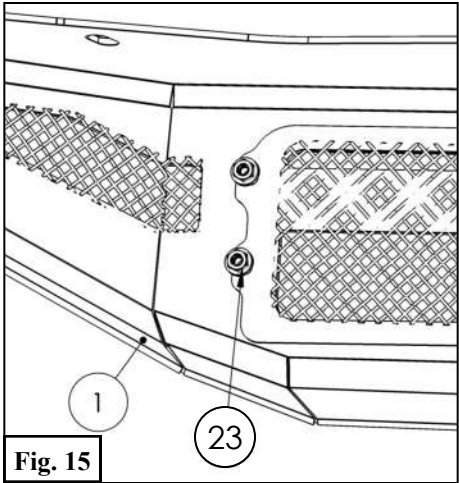
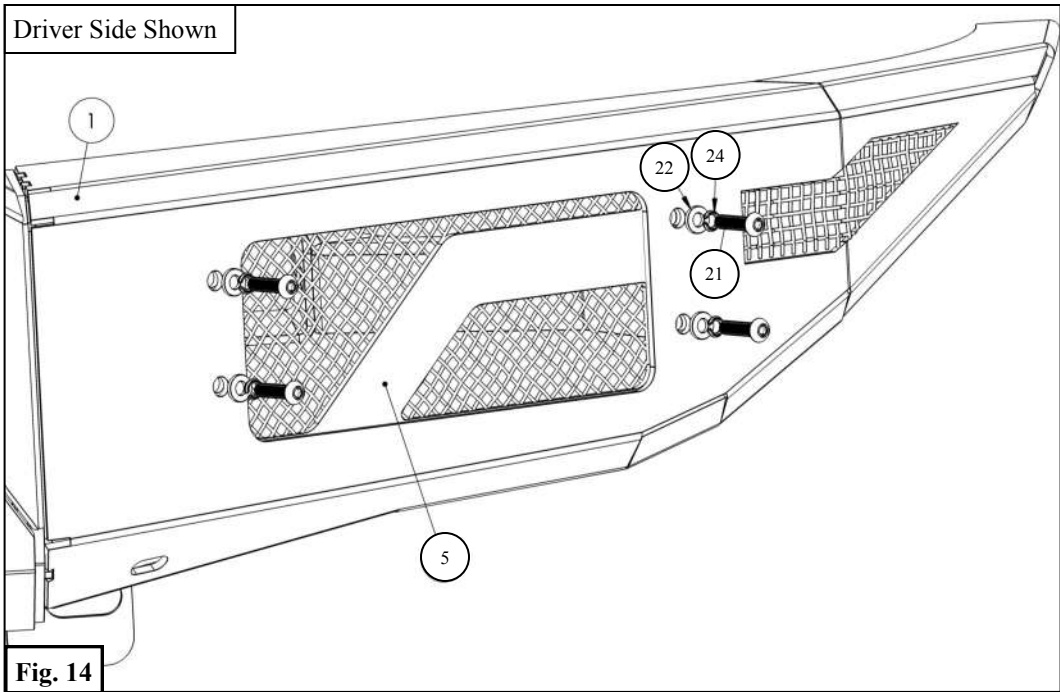
**Fig. 12**

- Use the supplied M8 and M10 Hardware to secure both the Side Straps (10,11) and Outer Support Straps (16,17) to the bumper and L-Brackets. See **Figure 13**.



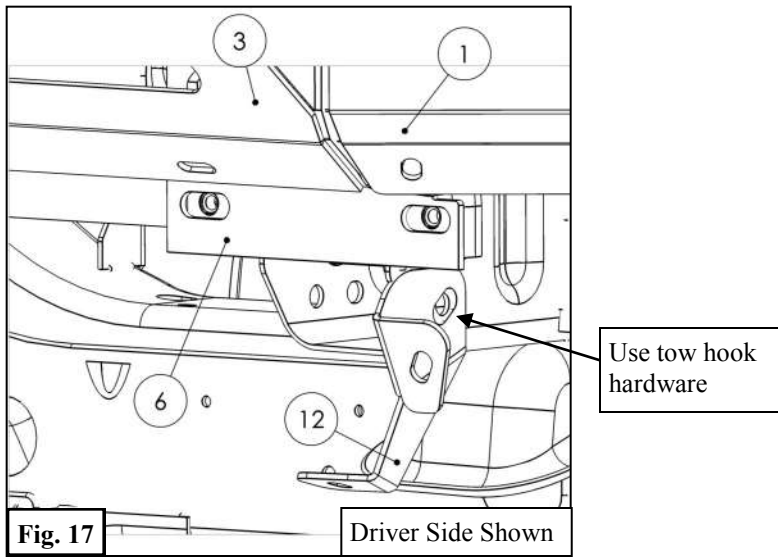
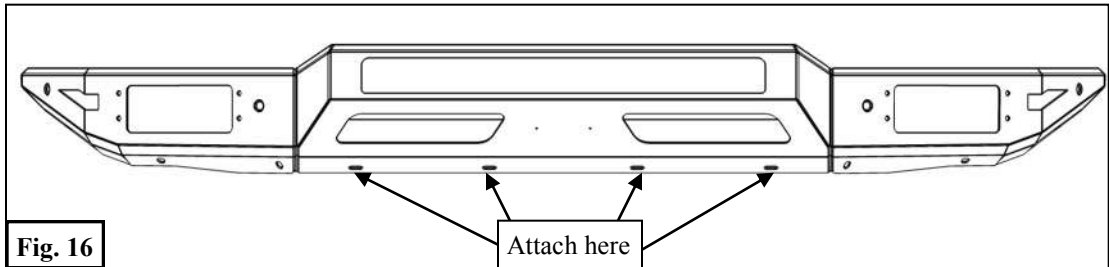
**Fig. 13**

11. Attach the Mesh Side Covers (5) to the Bumper using the supplied M6 Hardware. See **Figures 14 & 15**.



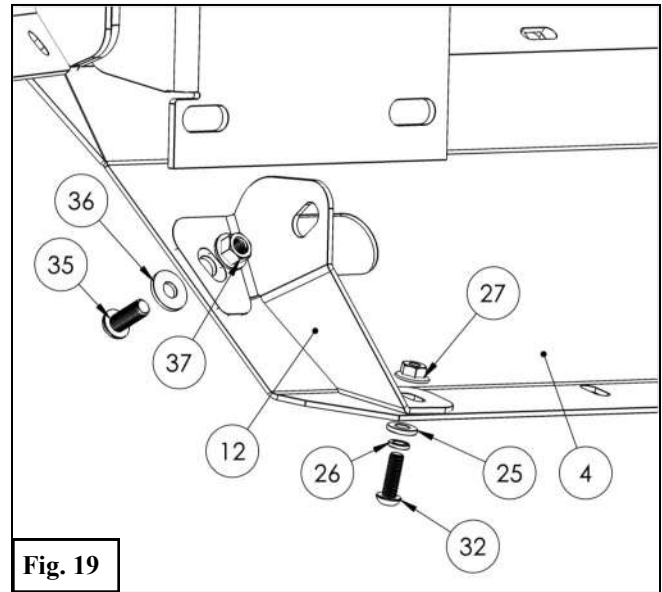
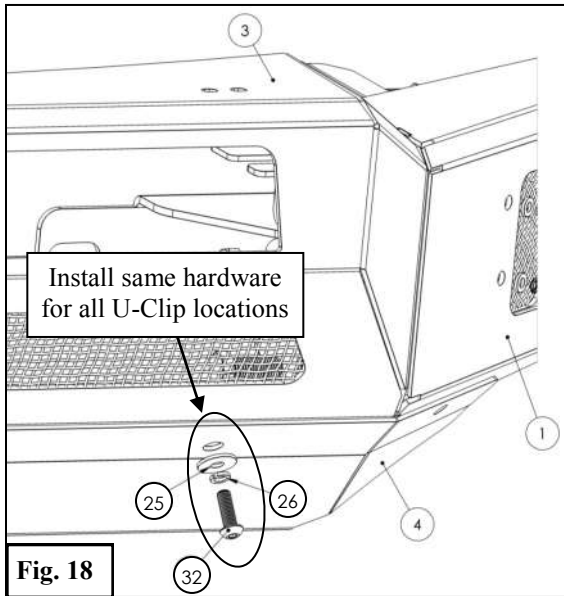
12. Attach the supplied M8 U-Clips (38) to the bumper. See **Figure 16**. *Note: If using the Outlaw Skid Plate (sold separately), skip this skid plate install.*

13. Use the factory tow hook hardware to attach the Valance Mounting Brackets (12,13). See **Figure 17**.

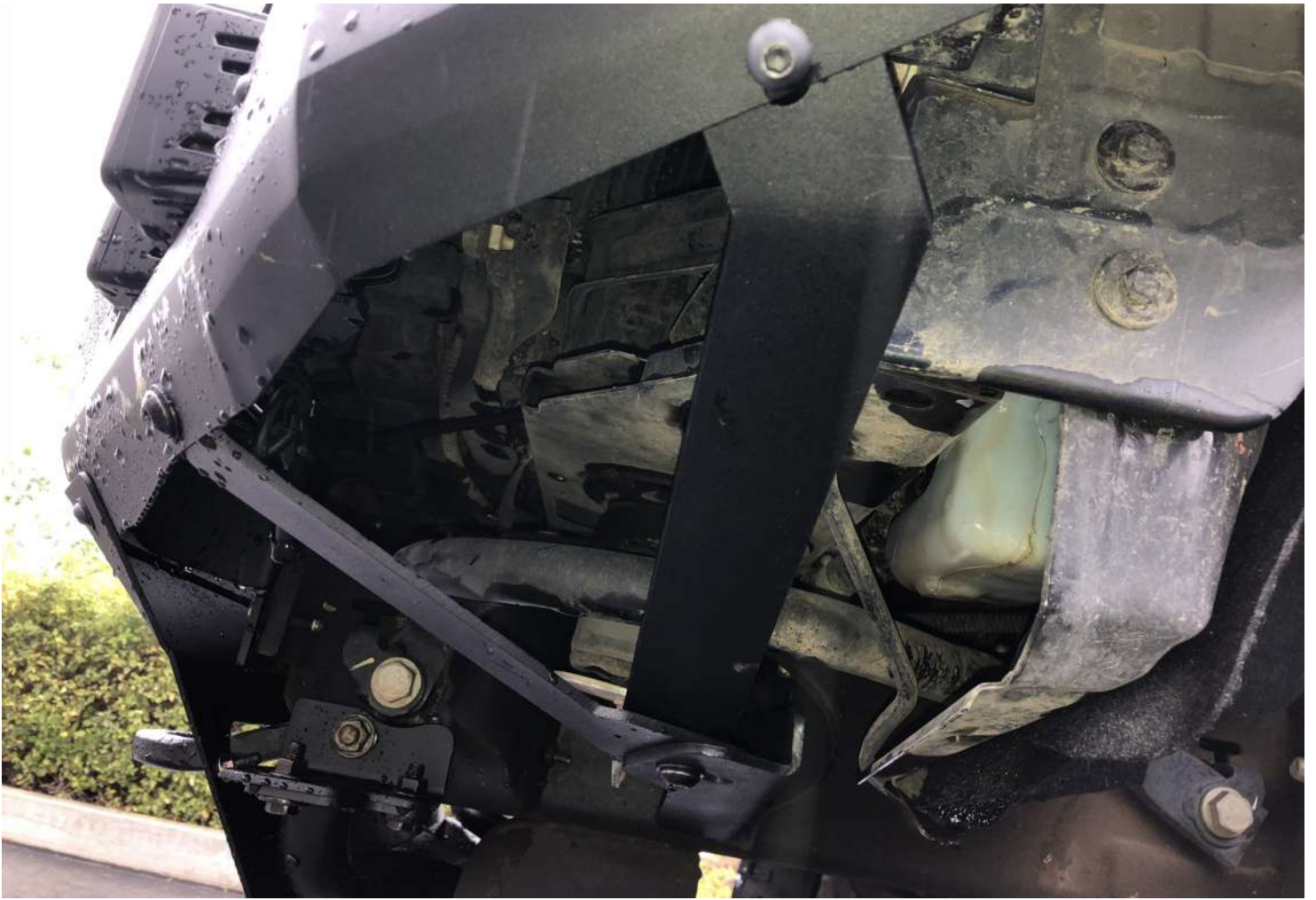




14. Install the Skid Plate to the bumper using the supplied M8 Hardware. See **Figure 18**.
15. Secure the Skid Plate (4) to the Valance Mounting Brackets using the supplied M8 and M10 Hardware. See **Figure 19**.
15. Align bumper as desired and tighten hardware as specified: M6 to 7 ft-lbs, M8 to 18 ft-lbs, M10 to 38 ft-lbs, M12 to 60 ft-lbs.
16. If installing lower skid plate P#58-71005, use items 18 and 19 to mount skid tube brackets to frame. See Figure 20 below.







---

---

**WESTIN**



INSTALLATION COMPLETE



LED Lights Sold Separately

**CARE INSTRUCTIONS**

- REGULAR WAXING IS RECOMMENDED. DO NOT USE ANY TYPE OF POLISH OR WAX THAT MAY CONTAIN ABRASIVES.
- STAINLESS STEEL PRODUCTS CAN BE CLEANED WITH MILD SOAP AND WATER. STAINLESS STEEL POLISH SHOULD BE USED TO POLISH SMALL SCRATCHES.
- GLOSS BLACK FINISHES SHOULD BE CLEANED WITH MILD SOAP AND WATER



## WARNING



Failure to follow these instructions could lead to death, personal injury, and / or property damage.

Failure to follow these instructions could lead to death, personal injury, and / or property damage.

### FASTENERS:

All Westin supplied fasteners must be utilized and installed in accordance with the installation instructions and apply torque to the specifications as defined. **DOUBLE CHECK ALL FASTENERS BEFORE INITIAL USE, AND PERIODICALLY IN THE FUTURE TO ENSURE PROPER FUNCTION AND SAFETY.**

### DRILLING:

Most Westin products do not require drilling for installation. If drilling is defined as required, use caution when drilling a vehicle. **FAILURE TO REVIEW AN AREA TO BE DRILLED MAY RESULT IN PERSONAL INJURY AND/OR INJURY TO OTHERS AS WELL AS VEHICLE DAMAGE.**

### EYE PROTECTION:

**ALWAYS WEAR SAFETY GLASSES OR GOGGLES DURING THE INSTALLATION PROCESS TO AVOID PERSONAL INJURY.**

### MAXIMUM TOWING/CARRYING CAPACITY: (if applicable)

The Westin Receiver Hitches will have a visible tow rating label affixed directly on the product. User should never exceed the vehicle manufacturers maximum tow and weight rating regardless of the capacity of the hitch. **FAILURE TO FOLLOW THESE GUIDELINES WILL VOID THE WESTIN WARRANTY AND MAY RESULT IN PERSONAL INJURY AND/OR INJURY TO OTHERS AS WELL AS VEHICLE DAMAGE.**

