

# INSTALLATION INSTRUCTIONS

## HDX BANDIT REAR BUMPER



APPLICATION:  
2015-2020 F-150  
PART NUMBER:  
58-341105

CONTENT			
ITEM	QUANTITY	DESCRIPTION	TOOLS NEEDED
1	1	BUMPER	10MM SOCKET
2	1	DRIVER FRAME BRACKET	10MM WRENCH
3	1	PASSENGER FRAME BRACKET	19MM SOCKET
4	1	DRIVER MAIN BRACKET	19MM WRENCH
5	1	PASSENGER MAIN BRACKET	TRIM TOOL
6	4	SENSOR L-TAB	RATCHET
7	4	SENSOR PLUG	TORQUE WRENCH
8	4	M12 DOUBLE BOLT PLATE	
9	6	M12 HEX HEAD BOLT	
10	14	M12 SPLIT LOCK WASHER	
11	20	M12 FLAT WASHER	
12	14	M12 HEX NUT	
13	2	M6 SOCKET BUTTON HEAD BOLT	
14	6	M6 FLAT WASHER	
15	2	M6 SERRATED FLANGE NUT	
16	4	M6 CARRIAGE BOLT	
18	4	M6 SPLIT LOCK WASHER	
19	4	M6 HEX NUT	

**ANTI-SEIZE LUBRICANT MUST BE USED ON ALL STAINLESS STEEL FASTENERS TO PREVENT THREAD DAMAGE AND GALLING**





## PROCEDURE

1. Remove contents from box, verify if all parts listed are present and free from damage. Carefully read and understand all instructions before attempting installation.  
**Failure to identify damage before installation could lead to a rejection of any claim.**

**NOTE: This bumper is compatible with the OEM hitch by removing a non structural component of the hitch. See procedure for details.**

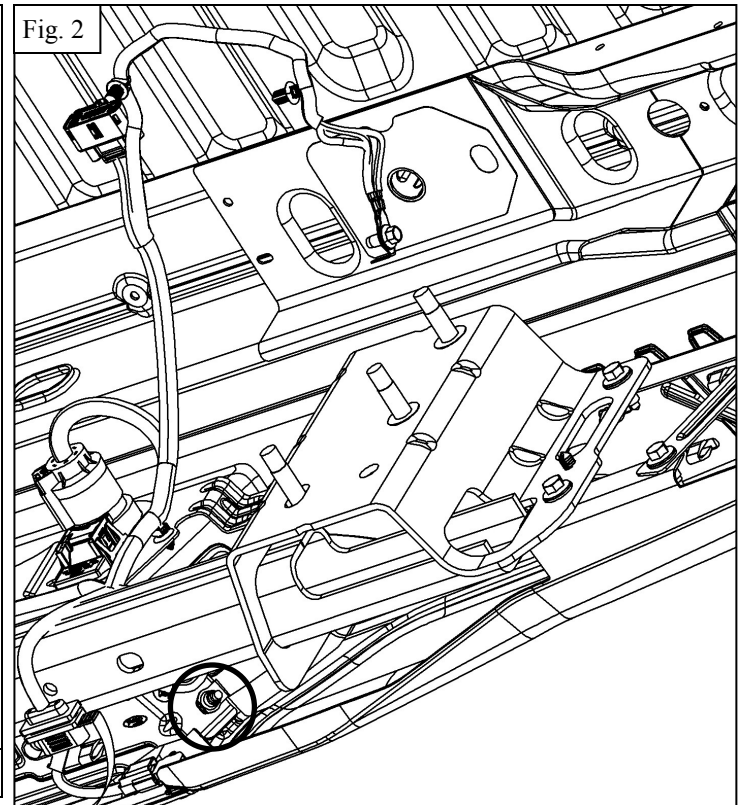
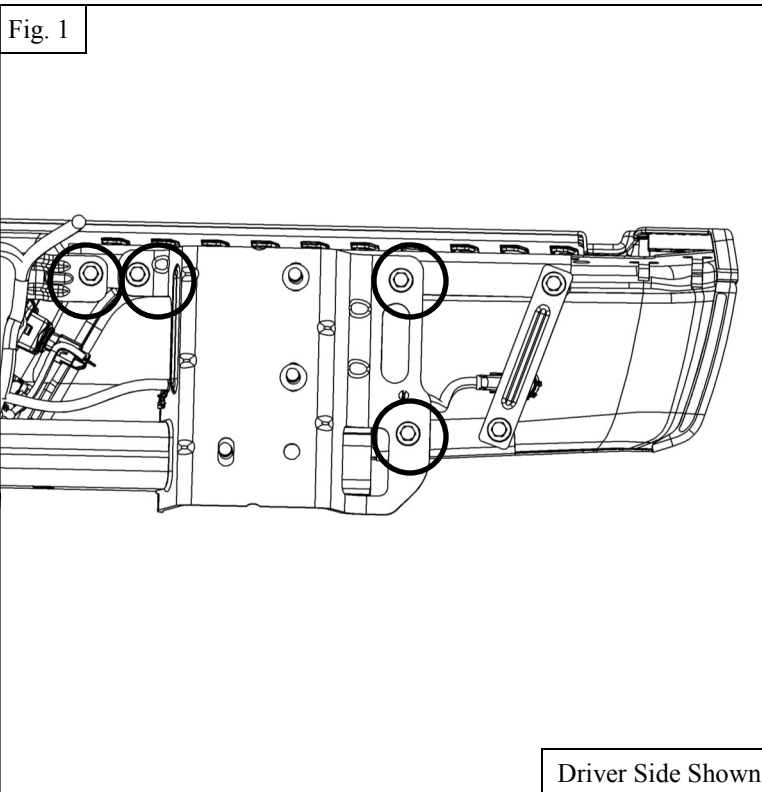
2. Start removing the rear bumper by removing the plastic portion. It should pop off of the vehicle. You may need a trim removal tool.
3. Remove the 5 bolts on each side of the bumper to remove the end caps. See **Figure 1-2**



5. In order to use OEM hitch, grind off the 5 welds holding the license plate sheet metal part. After removal, the hitch should look as shown on **Fig. 3**. Spray paint the raw metal to avoid rust.
6. After modifying the hitch, mount back on the vehicle with frame brackets **Items 2,3** using M12 hardware **Items 9-12**. See **Fig. 4**



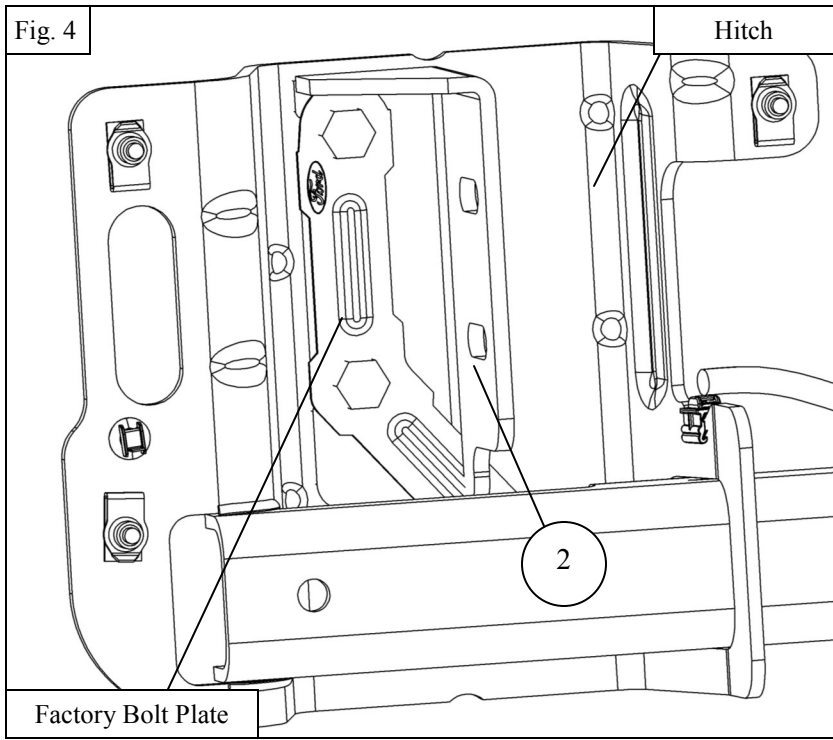

**PARKING SENSOR INSTALLATION**  
**\*If not installing sensors, install Hole Plugs into holes on bumper and proceed.**

5. Remove the parking sensors from the OEM bumper. Pay attention to the orientation of the sensors. They must be installed in the same orientation. Handle sensors with care, they are very delicate .
6. Use the Sensor Tab (6) along with the supplied M6 Hardware (14,16-19)to install the sensors as shown in **Figure 5-6.**
7. Carefully route the harness around the bumper.

Note: Zip ties or double sided tape can be used to route harness and to hold the sensor in position.

**Fig. 5**

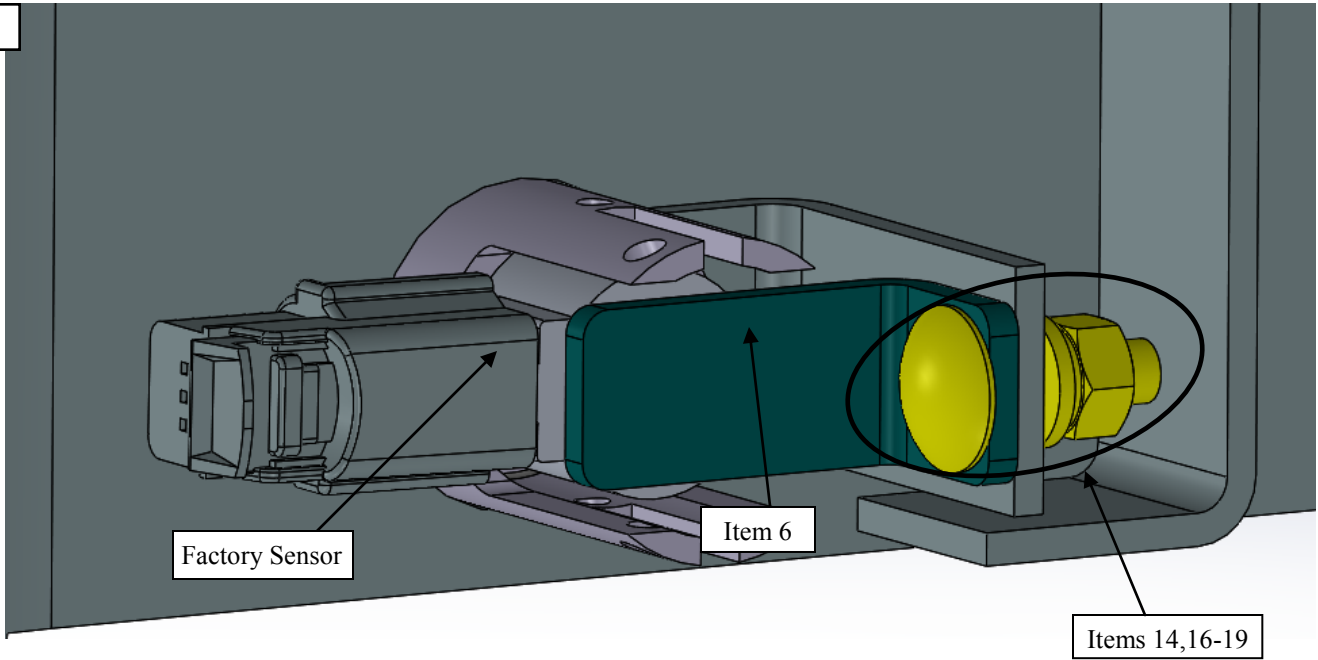
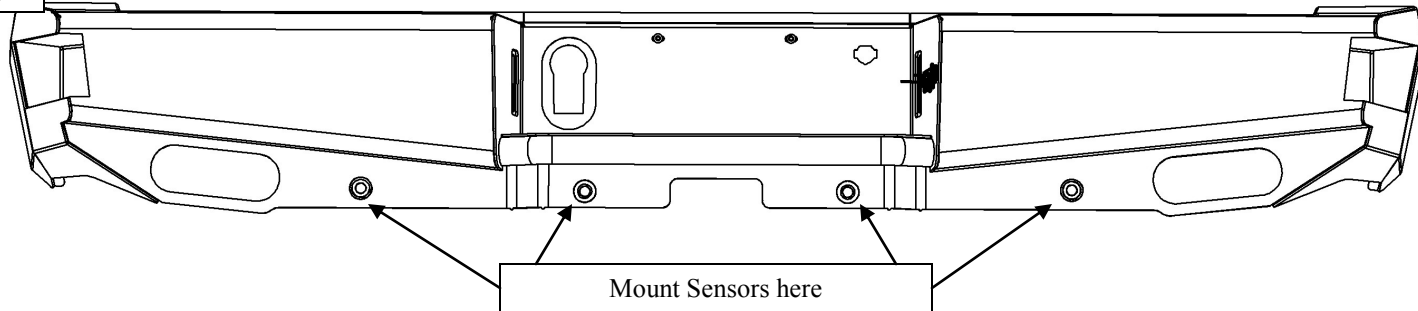

Fig. 6



8. Using the supplied M12 hardware, loosely assemble the bumper to the mounting brackets(4,5). See Figures 7-8
9. Use items 9-12 M12 hardware to mount frame bracket items 2 and 3 to frame and hitch.
10. Align bumper and make sure that it has enough clearance with open tailgate.
11. Torque all M6 hardware to 7-9 ft-lbs and M12 hardware to 70-80 ft-lbs,

Fig. 7

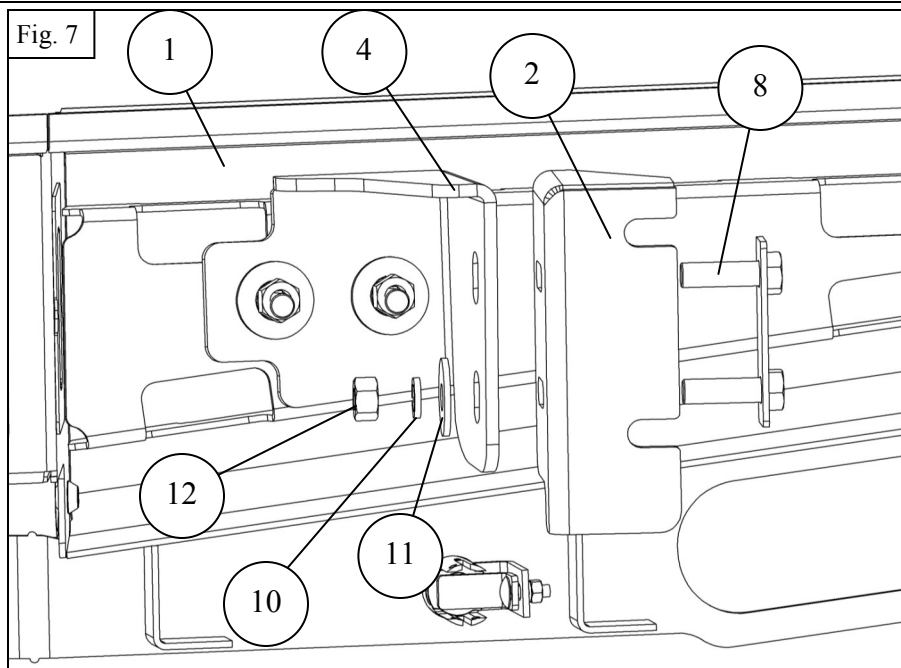
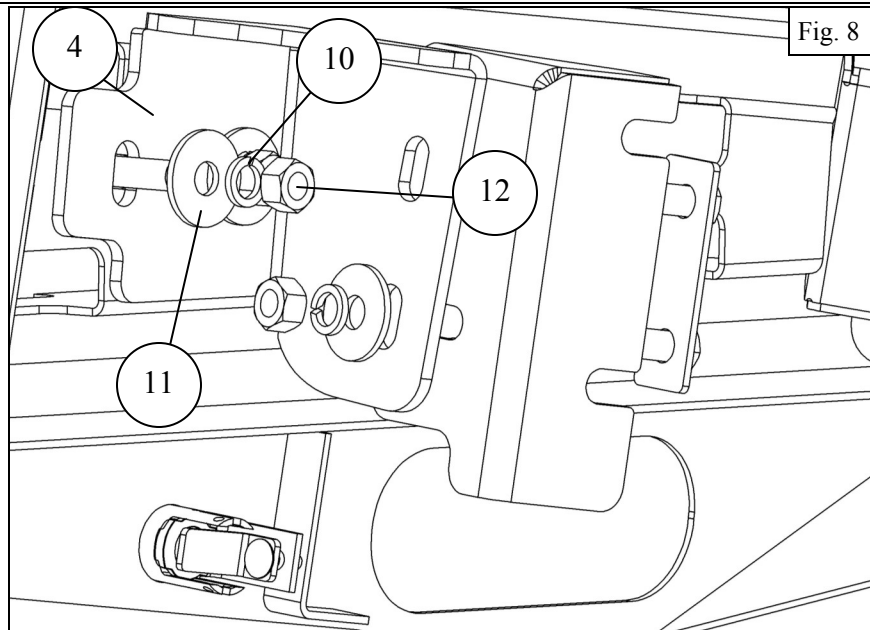

Fig. 8





INSTALLATION COMPLETE



#### CARE INSTRUCTIONS

- REGULAR WAXING IS RECOMMENDED. DO NOT USE ANY TYPE OF POLISH OR WAX THAT MAY CONTAIN ABRASIVES.
- STAINLESS STEEL PRODUCTS CAN BE CLEANED WITH MILD SOAP AND WATER. STAINLESS STEEL POLISH SHOULD BE USED TO POLISH SMALL SCRATCHES.
- GLOSS BLACK FINISHES SHOULD BE CLEANED WITH MILD SOAP AND WATER.

**WESTIN**



## WARNING



Failure to follow these instructions could lead to death, personal injury, and / or property damage.

Failure to follow these instructions could lead to death, personal injury, and / or property damage.

### FASTENERS:

All Westin supplied fasteners must be utilized and installed in accordance with the installation instructions and apply torque to the specifications as defined. **DOUBLE CHECK ALL FASTENERS BEFORE INITIAL USE, AND PERIODICALLY IN THE FUTURE TO ENSURE PROPER FUNCTION AND SAFETY.**

### DRILLING:

Most Westin products do not require drilling for installation. If drilling is defined as required, use caution when drilling a vehicle. **FAILURE TO REVIEW AN AREA TO BE DRILLED MAY RESULT IN PERSONAL INJURY AND/OR INJURY TO OTHERS AS WELL AS VEHICLE DAMAGE.**

### EYE PROTECTION:

**ALWAYS WEAR SAFETY GLASSES OR GOGGLES DURING THE INSTALLATION PROCESS TO AVOID PERSONAL INJURY.**

### MAXIMUM TOWING/CARRYING CAPACITY: (if applicable)

The Westin Receiver Hitches will have a visible tow rating label affixed directly on the product. User should never exceed the vehicle manufacturers maximum tow and weight rating regardless of the capacity of the hitch. **FAILURE TO FOLLOW THESE GUIDELINES WILL VOID THE WESTIN WARRANTY AND MAY RESULT IN PERSONAL INJURY AND/OR INJURY TO OTHERS AS WELL AS VEHICLE DAMAGE.**

### FOR CALIFORNIA RESIDENTS ONLY-PROP 65 WARNING:

Some products may contain chemicals such as DEHP, which can cause cancer, birth defects or other reproductive harm.



Learn more about off-road bumpers we have.