

# INSTALLATION INSTRUCTIONS

## HDX BANDIT FRONT BUMPER



### APPLICATION:

2019 Chevrolet Silverado 1500 (Excl. 2019 Silverado LD)

### PART NUMBER:

58-31135

CONTENT			
ITEM	QUANTITY	DESCRIPTION	TOOLS NEEDED
1	1	HDX BUMPER	18MM SOCKET
2	1	DRIVER MOUNTING BRACKET	18MM WRENCH
3	1	PASSENGER MOUNTING BRACKET	19MM SOCKET
4	1	DRIVER SUPPORT BRACKET A	19MM WRENCH
5	1	PASSENGER SUPPORT BRACKET A	10MM SOCKET
6	1	FOG LIGHT BRACKET A	10MM WRENCH
7	1	FOG LIGHT BRACKET B	15MM SOCKET
8	1	FOG LIGHT BRACKET C	RATCHET
9	1	FOG LIGHT BRACKET D	TORQUE WRENCH
10	1	DRIVER SUPPORT BRACKET B	PLIERS
11	1	PASSENGER SUPPORT BRACKET B	UTILITY KNIFE
12	2	SENSOR BRACKET	
13	2	PARKING SENSOR PLUG	
14	6	LONG M12 HEX HEAD CAP SCREW (YELLOW ZINC)	
15	6	SHORT M12 HEX HEAD SCREW (YELLOW ZINC)	
16	6	MEDIUM M12 HEX HEAD CAP SCREW (YELLOW ZINC)	
17	18	M12 SERRATED FLANGE NUT (YELLOW ZINC)	
18	4	M12 HEX NUT (YELLOW ZINC)	
19	22	M12 SPLIT LOCK WASHER (YELLOW ZINC)	
20	6	LARGE M12 FLAT WASHER (YELLOW ZINC)	
21	16	SMALL M12 FLAT WASHER (YELLOW ZINC)	
22	10	M10 HEX HEAD CAP SCREW (YELLOW ZINC)	
23	10	M10 SPLIT LOCK WASHER (YELLOW ZINC)	
24	10	M10 FLAT WASHER(YELLOW ZINC)	
25	8	M6 HEX HEAD CAP SCREW (BLACK ZINC)	
26	4	M6 ROUND HEAD SQUARE NECK CAP SCREW (BLACK ZINC)	
27	10	M6 HEX NUT (BLACK ZINC)	
28	12	M6 SPLIT LOCK WASHER (BLACK ZINC)	

**ANTI-SEIZE LUBRICANT MUST BE USED ON ALL STAINLESS STEEL FASTENERS TO PREVENT THREAD DAMAGE AND GALLING**



29	18	M6 FLAT WASHER (BLACK ZINC)	
30	2	LISCENSE PLATE GROMMET	
31	4	M12/M10 BOLT/NUT PLATE	

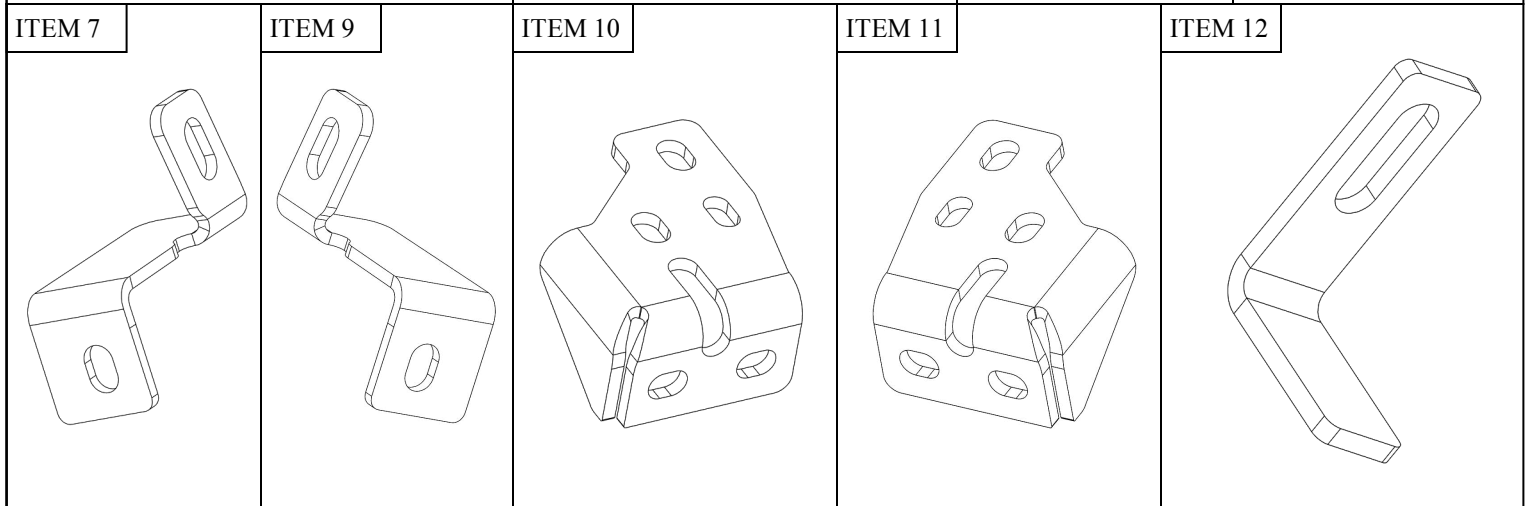
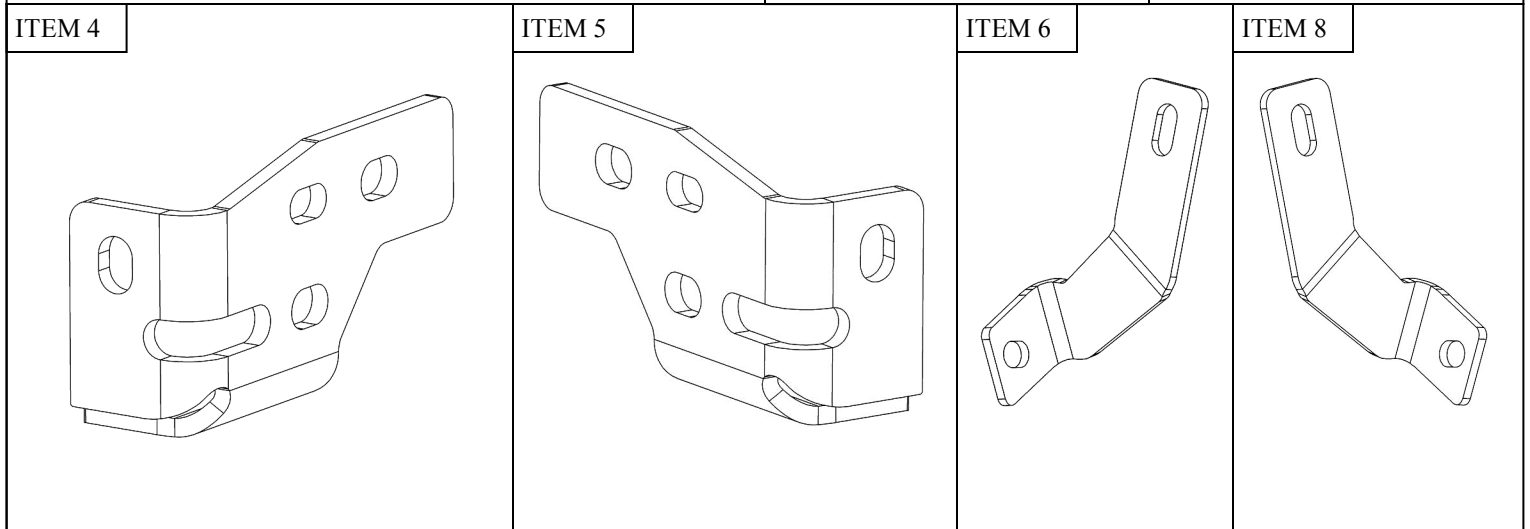
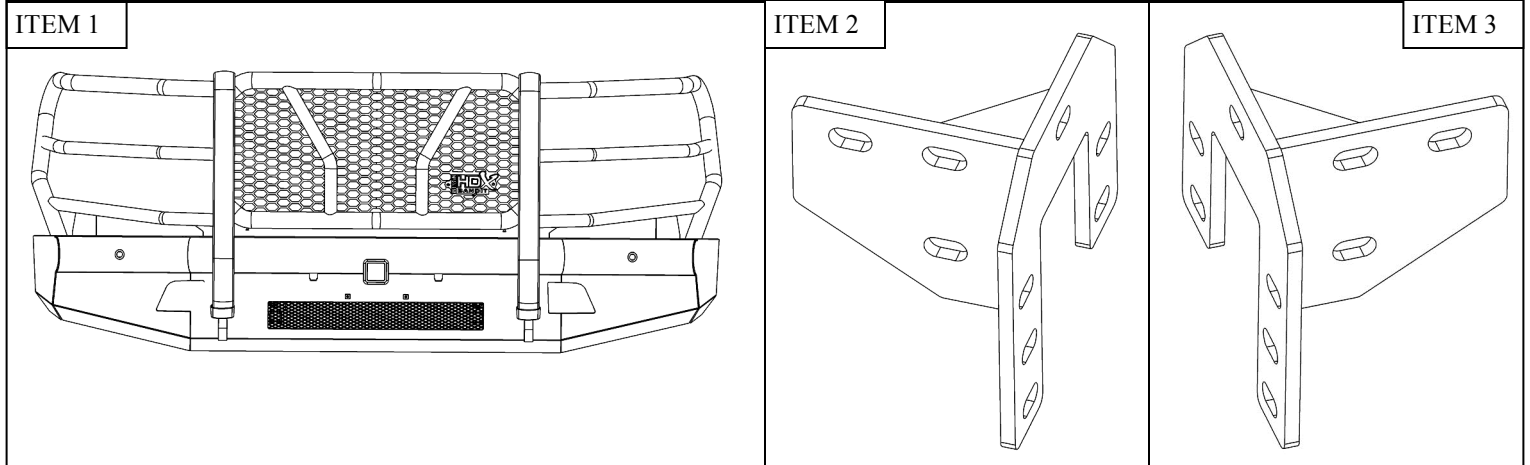

**PROCEDURE**

1. Remove contents from box, verify if all parts listed are present and free from damage.  
Carefully read and understand all instructions before attempting installation.  
**Failure to identify damage before installation could lead to a rejection of any claim.**

2. Begin by removing the plastic trim fasteners holding the grille in place. Also detach the clips of the wings of the grille. See **Figures 1 & 2**.
3. Remove the grille by pulling firmly and carefully at the bottom of the grille.

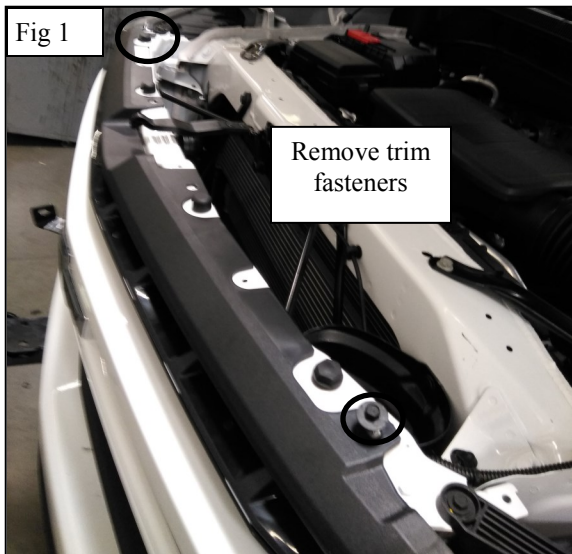

4. Remove the 4 bolts behind the plastic cover securing the bumper to the vehicle. See **Figure 3**.
5. Remove the bolts on the bottom of the frame securing the bumper supports to the vehicle. See **Figure 4**.
6. Unplug any wire connections and remove the bumper.

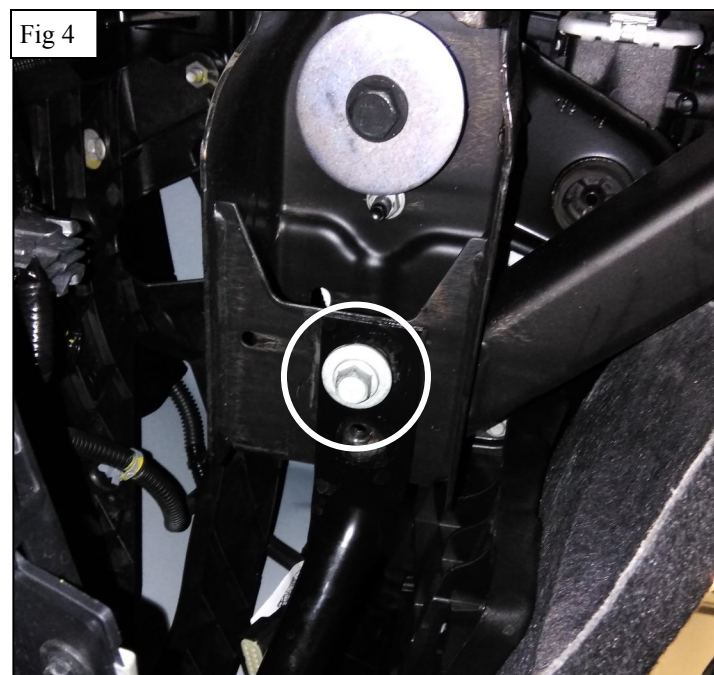

7. If reusing the factory fog lights, remove them from the OEM Bumper. If aftermarket lights will be used, install them at this time and move to **Step 9**.
8. Using Items 6-9 and supplied M6 hardware, reinstall the fog lights on to the Bandit bumper. **See Figure 5-6.**  
*Note: Fog light brackets "A" and "B" belong to the driver side while fog light brackets "C" and "D" belong to the passenger side*
9. If equipped, reinstall sensors on to the HDX Bandit bumper. *Note: A separate parts kit will need to be purchased in order to install parking sensors. Refer to PN 58-30005 for instructions.*

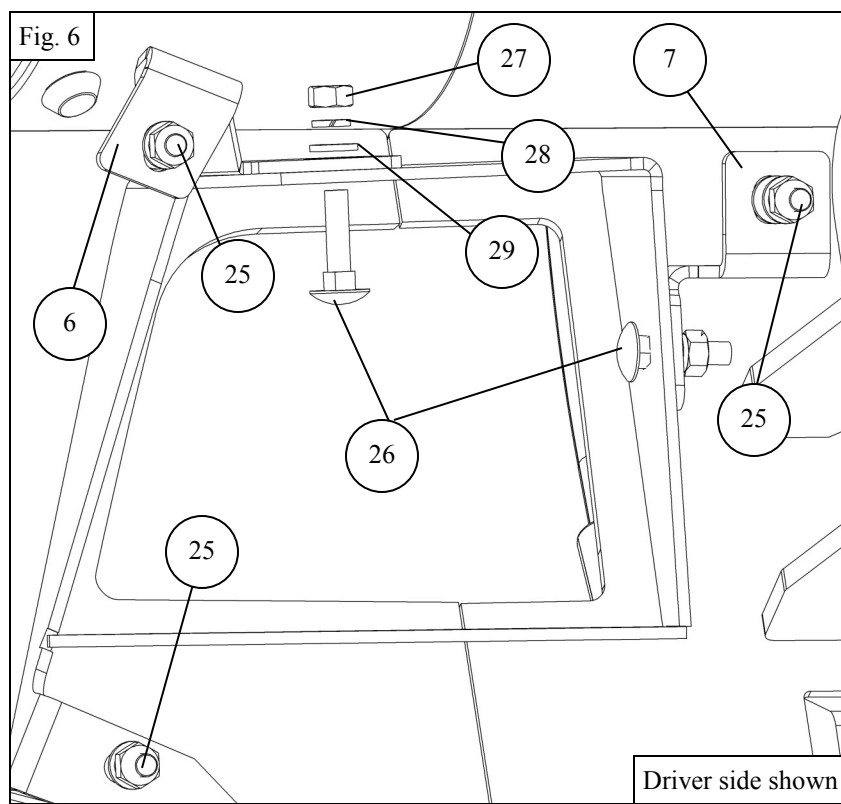
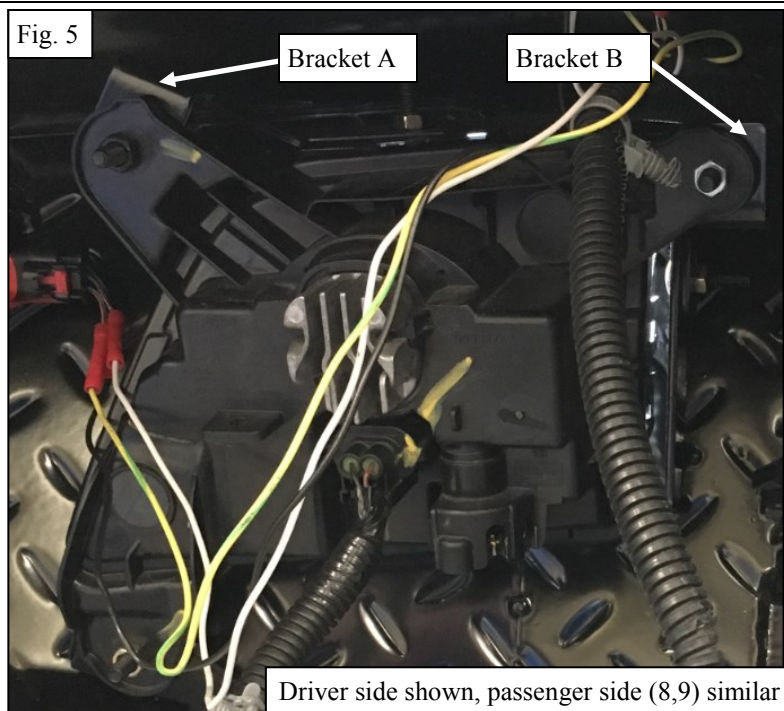



10. Install the mounting brackets onto the frame using supplied M10 hardware. You will use the factory welded M10 nuts to mount the brackets. See **Figure 7-8**.
11. Install the Support brackets on to the frame and main brackets using supplied M10 and M12 hardware. **Note: 1** You will have to slide the bolt/nut plate through the exposed hole in the frame in order to install support brackets. **Note 2:** Be sure to install nut plate with the M12 bolt side facing towards the front of the vehicle. See **Figures 9-11**.

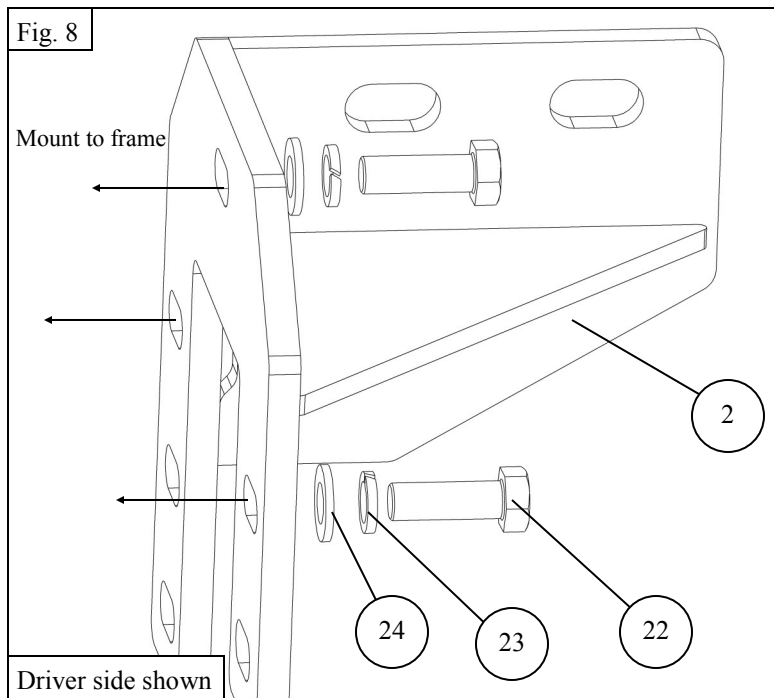

Fig. 9

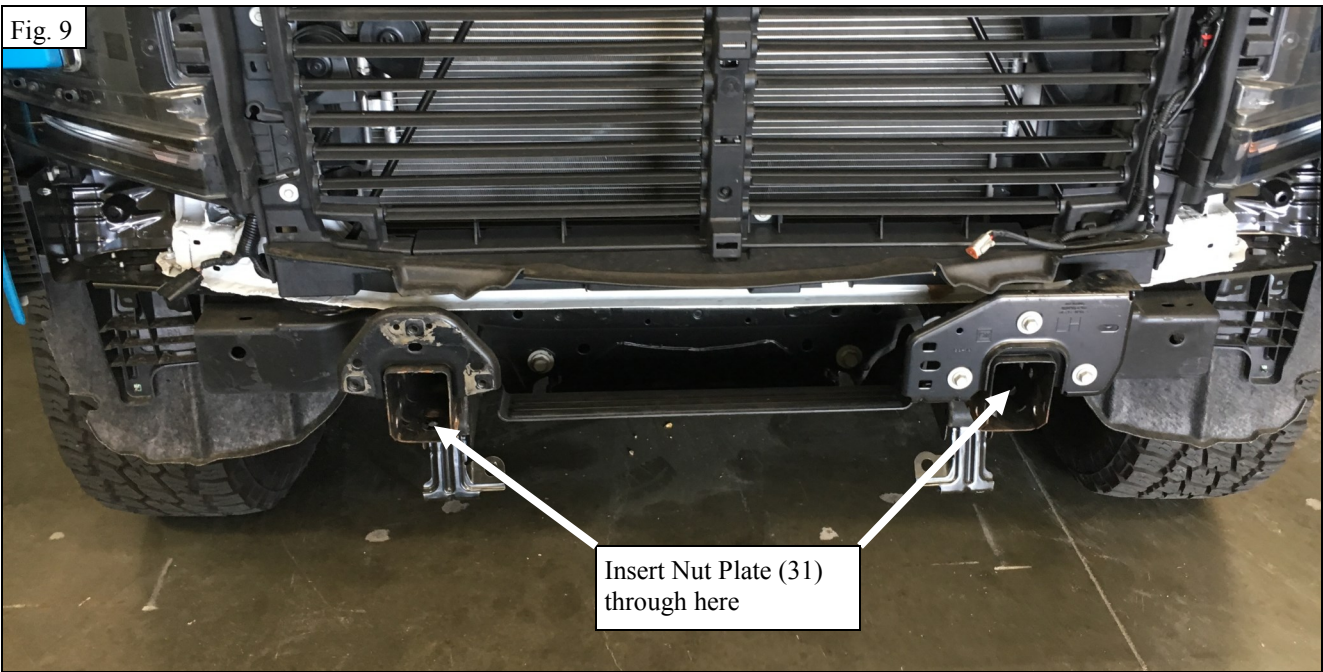
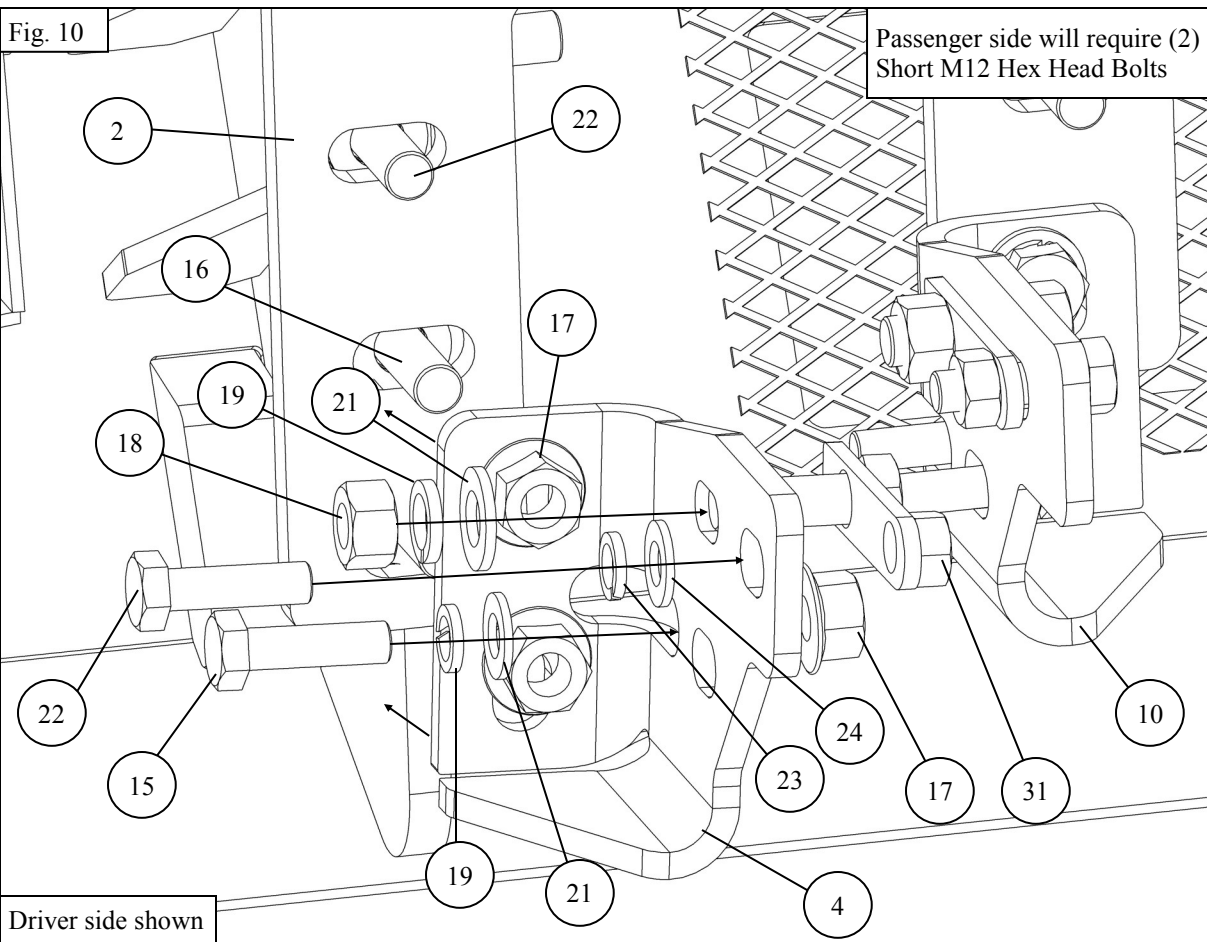
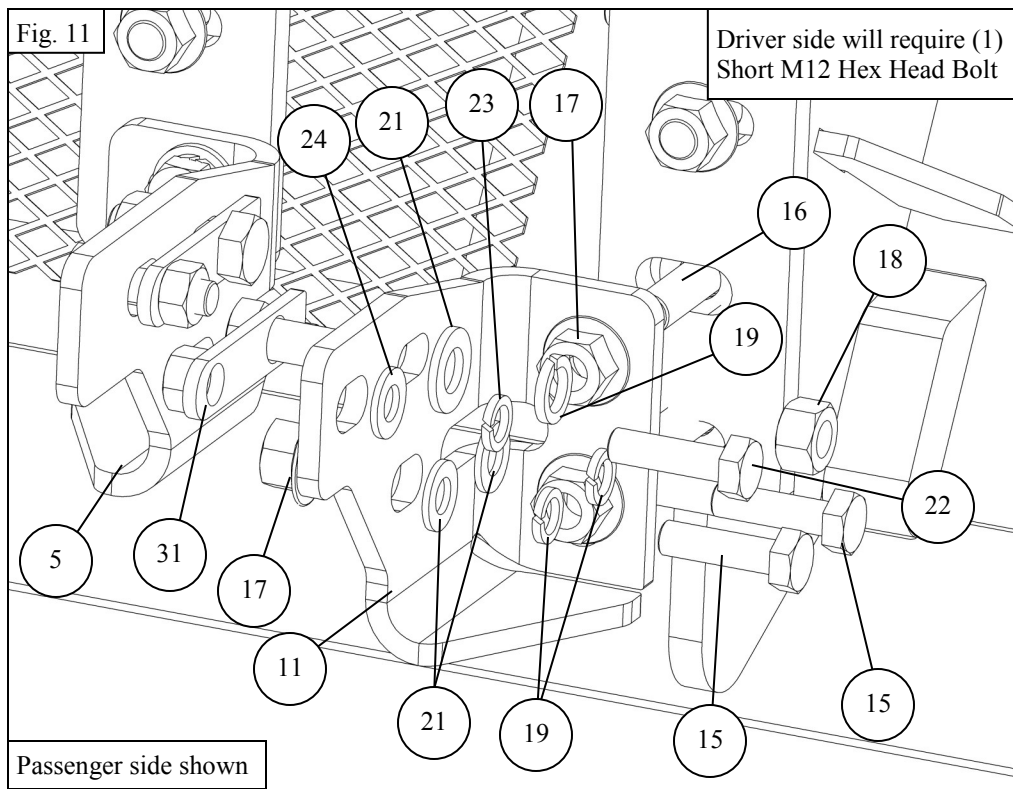
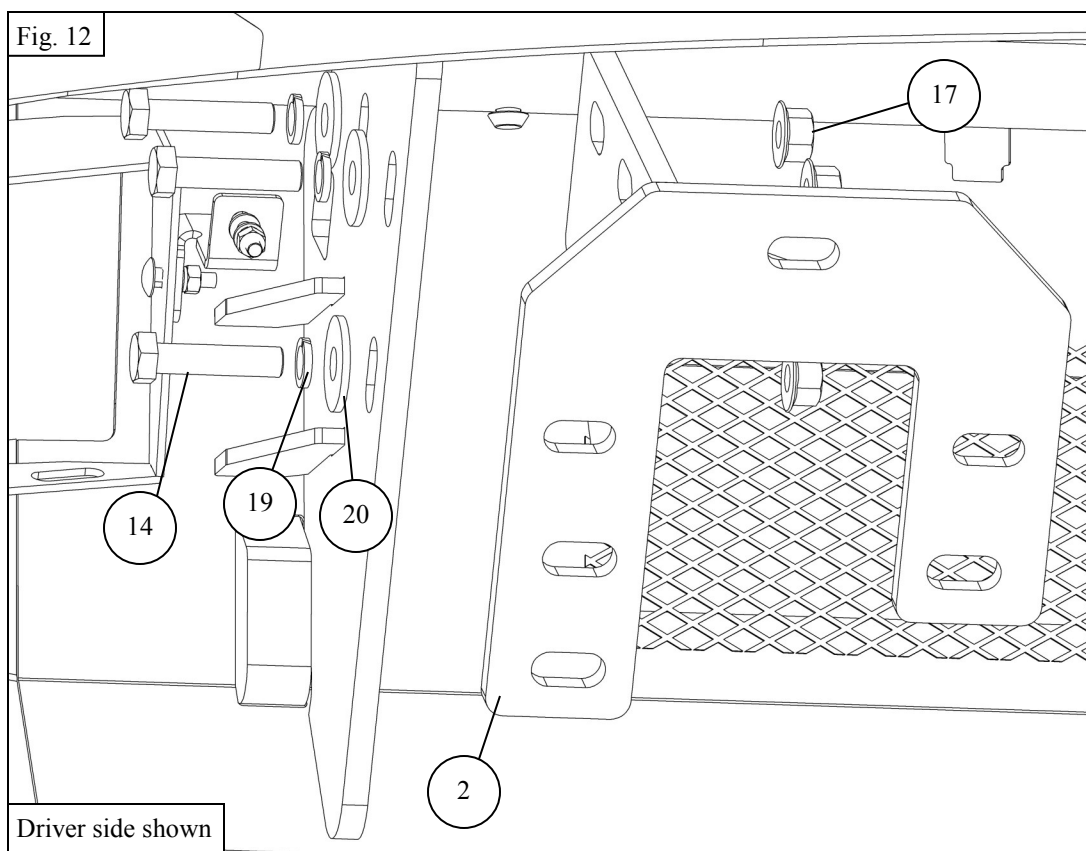

Fig. 10





12. With help, lift the HDX Bumper (1) into place between the Mount Brackets (2,3) and attach with supplied M12 Hardware. See Figure 12. **CAUTION:** The HDX Bandit Bumper is very heavy. The use of a floor jack or hoist is recommended.





13. Install the two license plate grommets as shown in **Figure 13** and install license plate using OEM hardware.
14. Trim the inner fender as desired. See **Figure 14**.
15. Align and adjust the bumper as necessary. Once the desired fit is achieved, torque all hardware as specified: torque M10 Hardware to 30-35 ft-lbs, M12 to 45-50 ft-lbs.

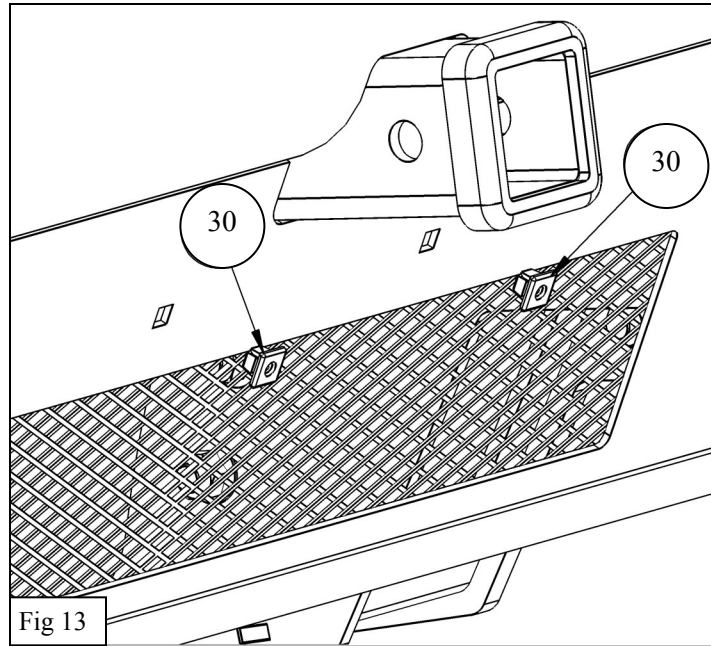



INSTALLATION COMPLETE



#### CARE INSTRUCTIONS

- REGULAR WAXING IS RECOMMENDED. DO NOT USE ANY TYPE OF POLISH OR WAX THAT MAY CONTAIN ABRASIVES.
- STAINLESS STEEL PRODUCTS CAN BE CLEANED WITH MILD SOAP AND WATER. STAINLESS STEEL POLISH SHOULD BE USED TO POLISH SMALL SCRATCHES.
- GLOSS BLACK FINISHES SHOULD BE CLEANED WITH MILD SOAP AND WATER.

**WESTIN**



## WARNING



Failure to follow these instructions could lead to death, personal injury, and / or property damage.

Failure to follow these instructions could lead to death, personal injury, and / or property damage.

### FASTENERS:

All Westin supplied fasteners must be utilized and installed in accordance with the installation instructions and apply torque to the specifications as defined. **DOUBLE CHECK ALL FASTENERS BEFORE INITIAL USE, AND PERIODICALLY IN THE FUTURE TO ENSURE PROPER FUNCTION AND SAFETY.**

### DRILLING:

Most Westin products do not require drilling for installation. If drilling is defined as required, use caution when drilling a vehicle. **FAILURE TO REVIEW AN AREA TO BE DRILLED MAY RESULT IN PERSONAL INJURY AND/OR INJURY TO OTHERS AS WELL AS VEHICLE DAMAGE.**

### EYE PROTECTION:

**ALWAYS WEAR SAFETY GLASSES OR GOGGLES DURING THE INSTALLATION PROCESS TO AVOID PERSONAL INJURY.**

### MAXIMUM TOWING/CARRYING CAPACITY: (if applicable)

The Westin Receiver Hitches will have a visible tow rating label affixed directly on the product. User should never exceed the vehicle manufacturers maximum tow and weight rating regardless of the capacity of the hitch. **FAILURE TO FOLLOW THESE GUIDELINES WILL VOID THE WESTIN WARRANTY AND MAY RESULT IN PERSONAL INJURY AND/OR INJURY TO OTHERS AS WELL AS VEHICLE DAMAGE.**

### FOR CALIFORNIA RESIDENTS ONLY-PROP 65 WARNING:

Some products may contain chemicals such as DEHP, which can cause cancer, birth defects or other reproductive harm.



Learn more about off-road bumpers we have.