



INSTALLATION INSTRUCTIONS

HDX WINCH MOUNT GRILLE GUARD, MAX WINCH TRAY

APPLICATION:

2019-2020 RAM 2500/3500

PART NUMBER:

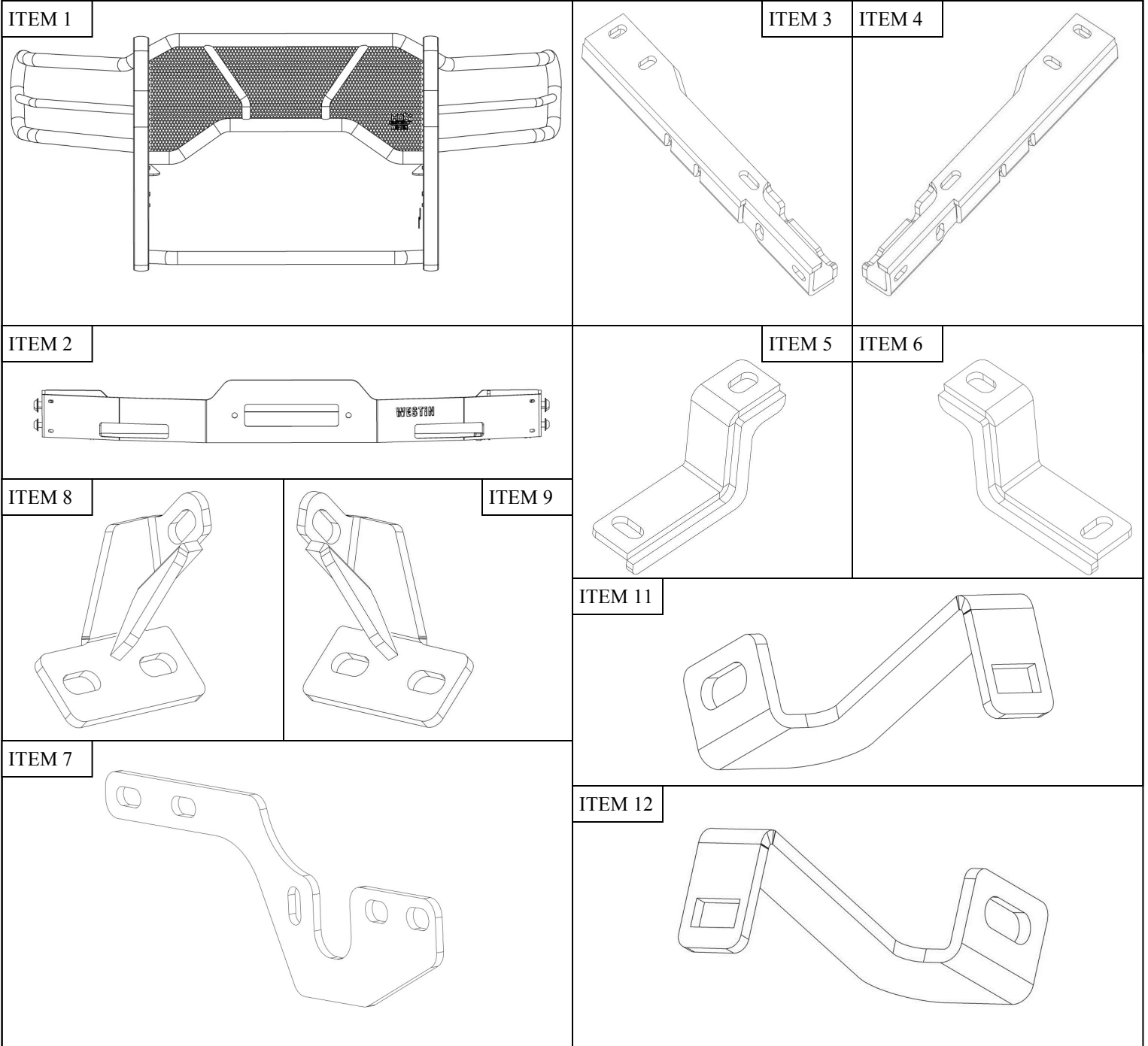
46-24025, 57-94025

CONTENT			
ITEM	QUANTITY	DESCRIPTION	TOOLS NEEDED
1	1	GRILLE GUARD	18MM SOCKET
2	1	WINCH TRAY	18MM WRENCH
3	1	LOWER DRIVER MOUNTING BRACKET	16MM SOCKET
4	1	LOWER PASSENGER MOUNTING BRACKET	16MM WRENCH
5	1	LOWER DRIVER SUPPORT BRACKET	ALLEN
6	1	LOWER PASSENGER SUPPORT BRACKET	TORQUE WRENCH
7	2	SIDE SUPPORT PLATE	RATCHET
8	1	UPPER DRIVER SUPPORT BRACKET	CUTTING TOOL
9	1	UPPER PASSENGER SUPPORT BRACKET	
10	2	M12 BOLT PLATE	
11	1	DRIVER UPPER STRAP	
12	1	PASSENGER UPPER STRAP	
MAX WINCH TRAY HARDWARE			
13	14	LONG M12 HEX HEAD BOLTS	
14	4	SHORT M12 SERRATED HEX HEAD FLANGE BOLT CLASS 10.9	
15	8	M12 SERRATED FLANGE NUT	
16	2	MEDIUM LENGTH M12 HEX HEAD BOLT	
17	16	LARGE M12 FLAT WASHER	
18	12	SMALL M12 FLAT WASHER	
19	14	M12 SPRING LOCK WASHER	
20	14	M12 HEX NUT	
21	2	M10 SERRATED FLANGE BOLT	
22	2	M10 SERRATED FLANGE NUTS	
23	2	M12 SERRATED BELLVILLE WASHER	
24	4	M12 PLASTIC RETAINER	
25	2	M10 PLASTIC RETAINER	
26	4	M12 FISH WIRE	
27	2	M10 FISH WIRE	
ANTI-SEIZE LUBRICANT MUST BE USED ON ALL STAINLESS STEEL FASTENERS TO PREVENT THREAD DAMAGE AND GALLING			



GRILLE GUARD ASSEMBLY HARDWARE

28	8	M12 BUTTON HEAD BOLT	
29	8	M12 SERRATED BELLVILLE WASHERS	
30	8	M12 SERRATED FLANGE HEX NUT	



PROCEDURE

1. Remove contents from box, verify if all parts listed are present and free from damage.

Carefully read and understand all instructions before attempting installation.

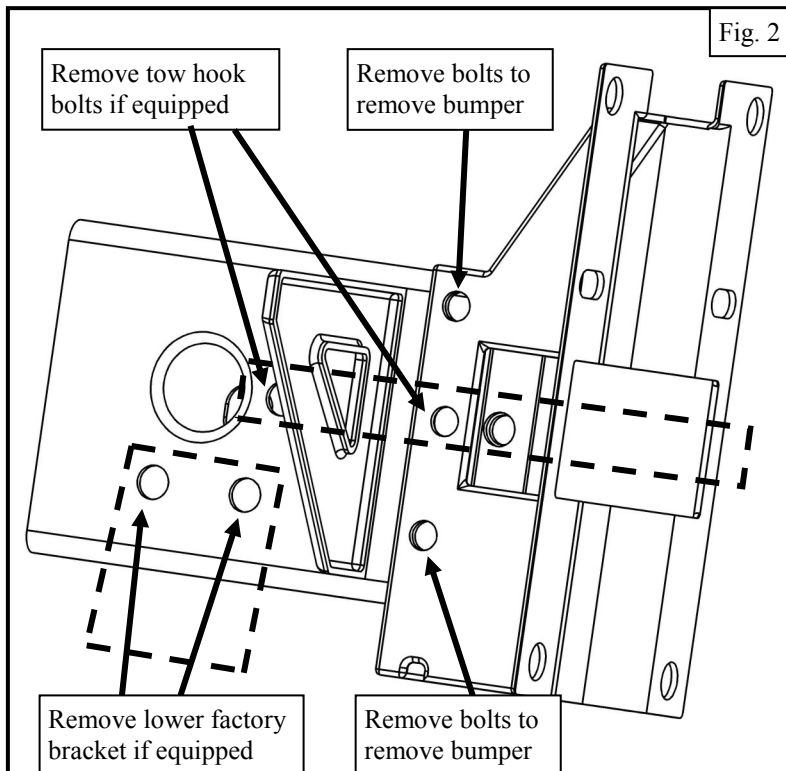
Failure to identify damage before installation could lead to a rejection of any claim.

2. Start below the front of the vehicle. Unbolt the two factory bolts (four if tow hooks are equipped) from the bumper bracket on each side. Remove 2 lower factory bracket bolts to remove it from the vehicle. **See Figure 1 & 2** Note: (Tow hooks cannot be reused and lower factory bracket cannot be reused.)

Fig. 1

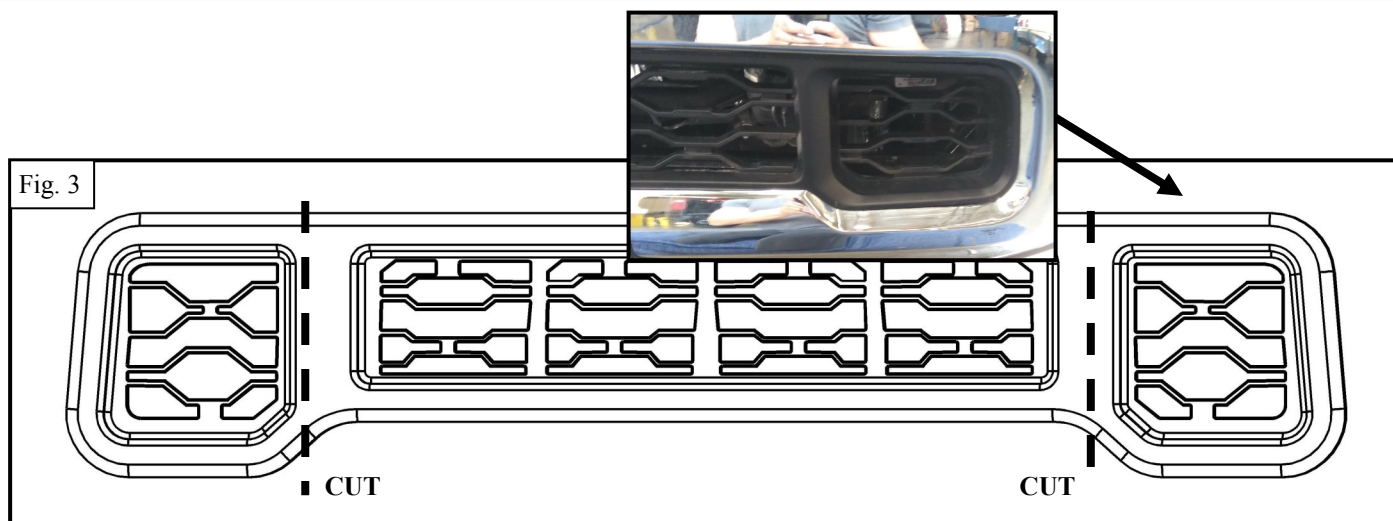


Fig. 2



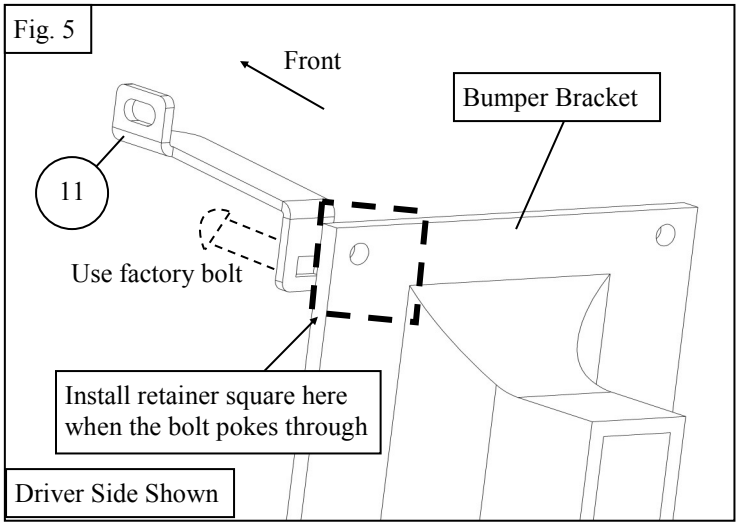
3. Unplug any lights or wiring and remove the bumper.
4. Once bumper is removed unbolt and pry the center mesh in the bumper.
5. Proceed to cutting the side pockets. **Note:** (You may try to trim only the necessary area needed for the brackets to poke through but it will be a much easier installation process if the sides are completely cut off.) **See Figure 3**
6. Reinstall the mesh to the bumper using the previously removed nuts.

Fig. 3

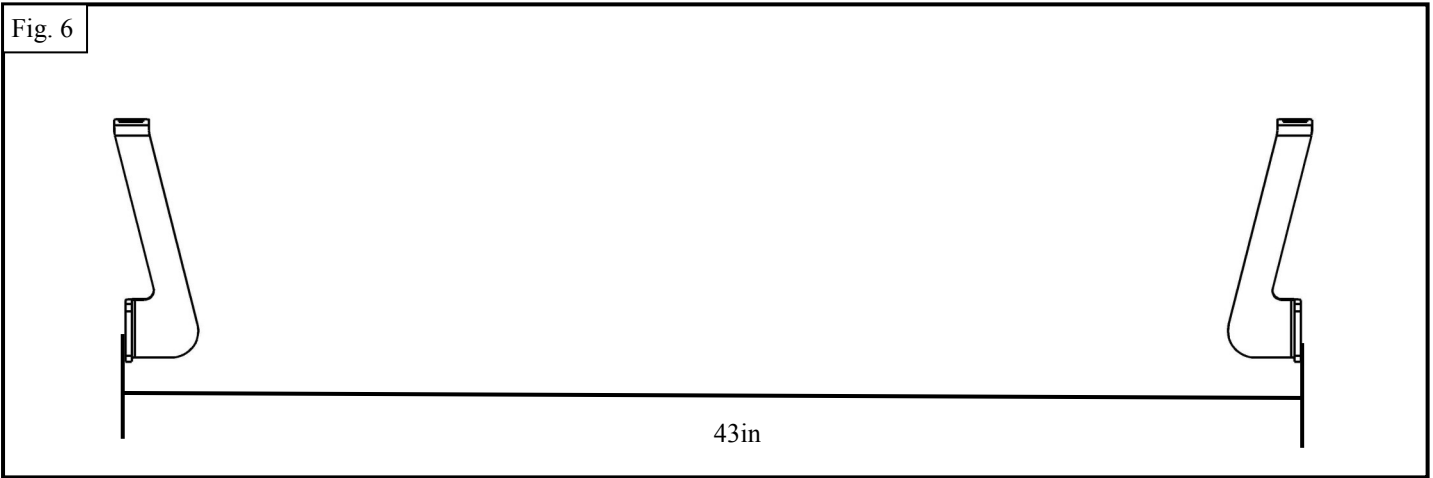


ONLY FOR INSTALLATION OF GRILLE GUARD IF ONLY INSTALLING WINCH TRAY SKIP THIS PAGE AND PROCEED TO PAGE 5.

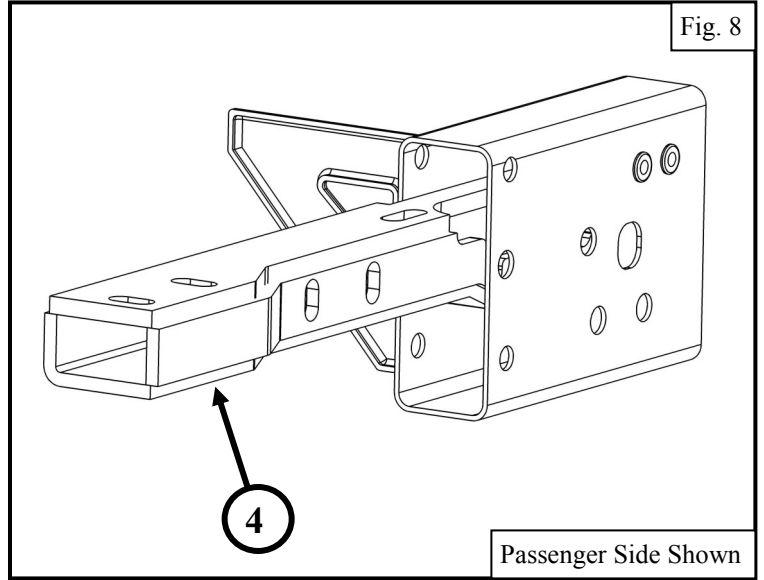
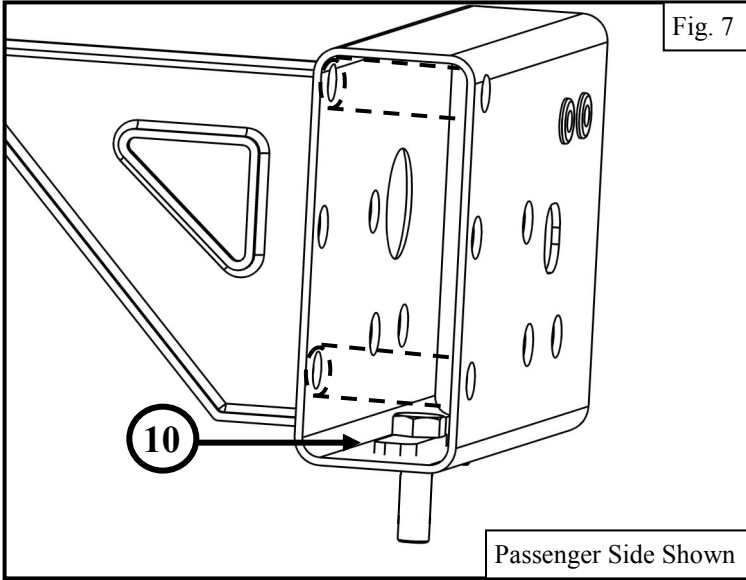
- 7. Remove the top outside corner nut and bolt off of each bumper bracket. **See Figure 3**
- 8. **If Installing the grille guard:** Install a plastic M12 retainer onto the factory bolt once it passes through the hole. Install the strap on to the upper left hole of the bumper bracket. (Trq: 60 ft-lbs). Repeat on the passenger side. **See Figure 4**



- 9. Make sure the support straps are 43 inches apart to make sure that the grille guard can be installed. **See Figure 6**

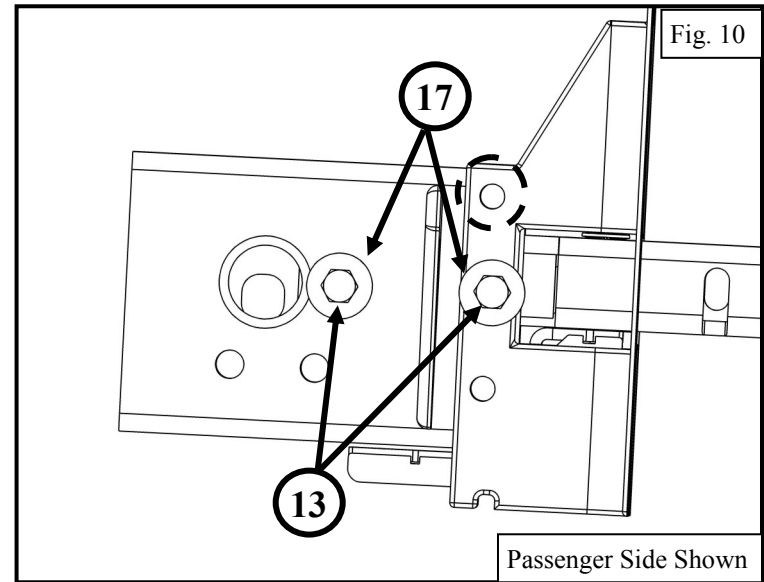
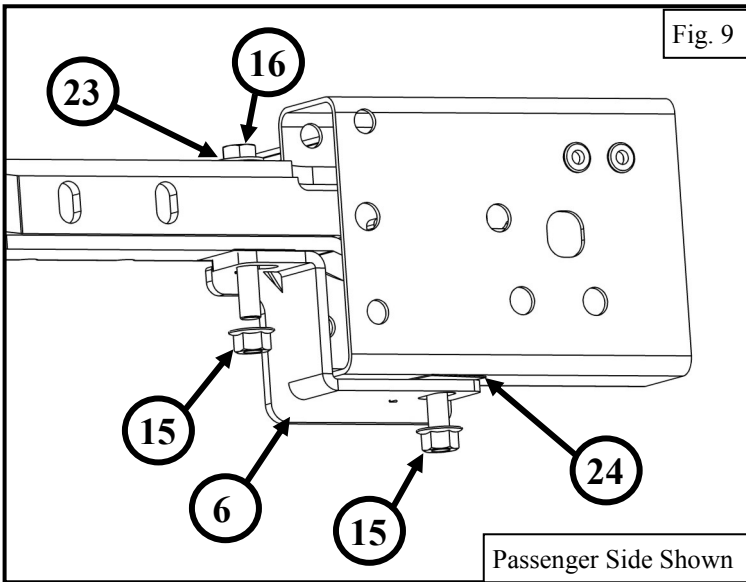


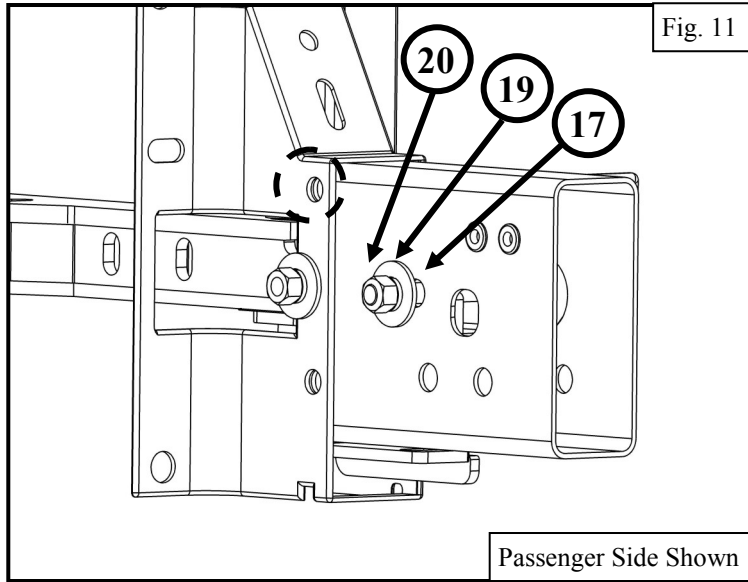
10. Insert M12 bolt plate into the frame and slide through bottom hole. Note: (Use M12 Fish Wire if necessary.) See Figure 7
 11. Slide lower mount bracket into frame. See Figure 8



12. Loosely install lower support bracket to frame and lower mount bracket with supplied M12 hardware. See Figure 9
BUMPER REINSTALLATION

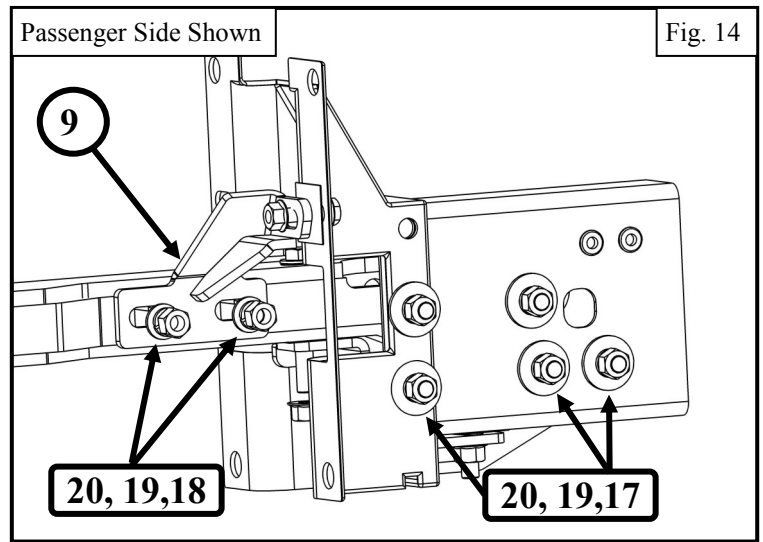
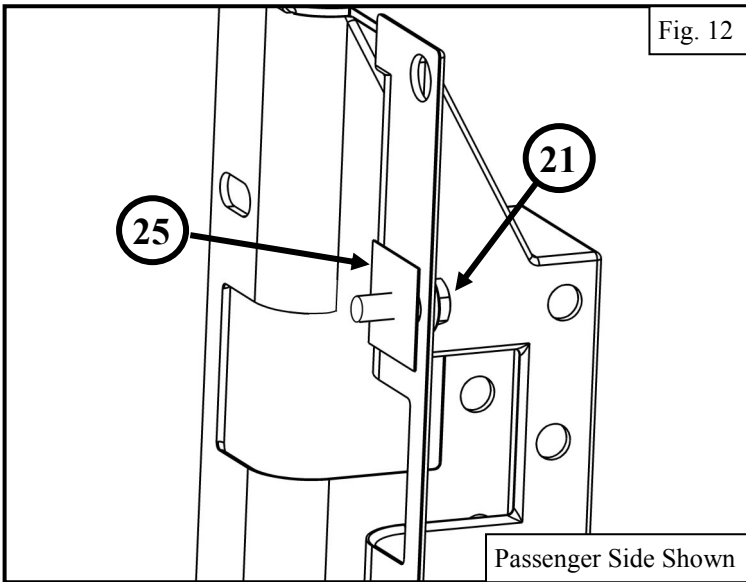
13. Install previously removed bumper by sliding the bumper bracket over the frame and lower mount. Note: (Be sure to re-connect any wiring harnesses.). Loosely install the bumper bracket and the lower mount bracket to the frame using the supplied M12 hardware. Install only top OE bolt and nut to secure the bumper. See Figure 10 & 11

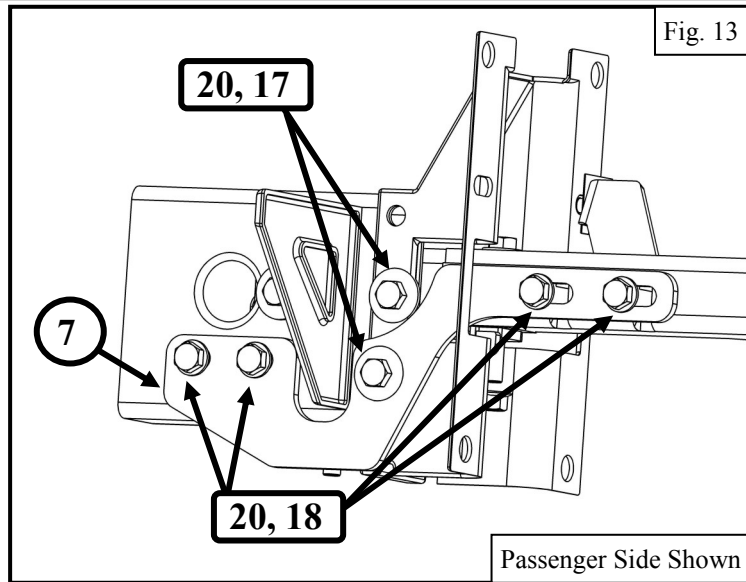




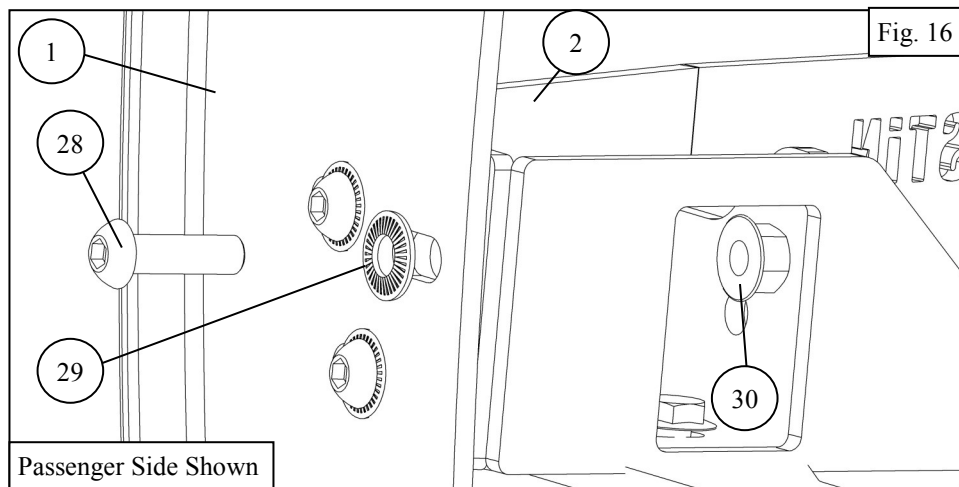
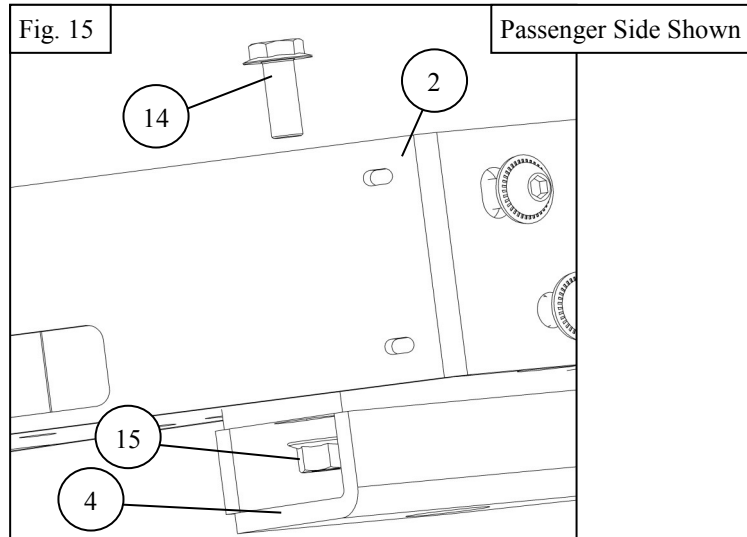
6

- 14. After bumper is installed slide the M10 bolt through the bumper bracket and secure with supplied plastic retainer. See **Figure 12**
- 15. Install upper support strap to frame, lower mount bracket and side support bracket using supplied M12 hardware. See **Figure 13 & 14**

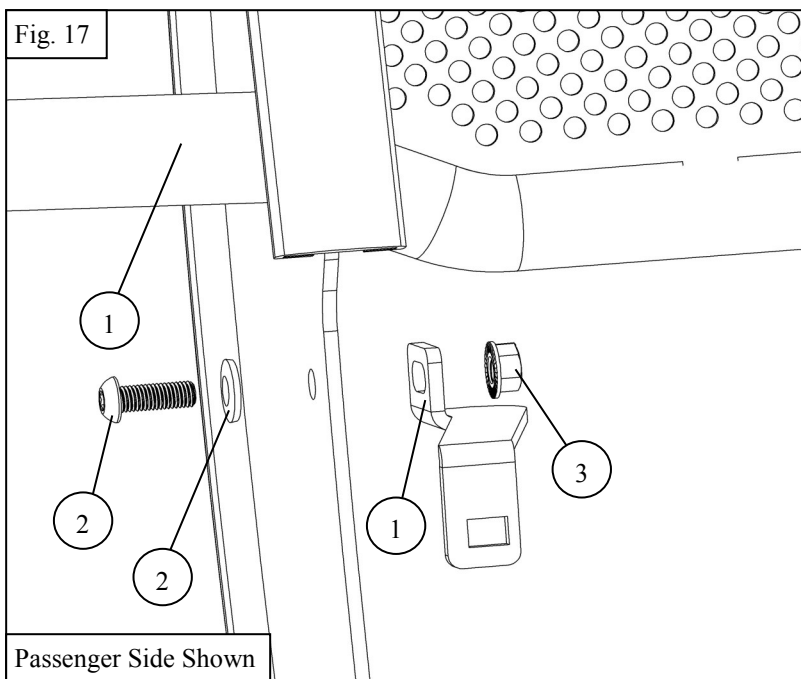




16. Using the supplied M12 hardware, install the winch tray on to the mounting brackets. **Critical!: make sure you use the class 10.9 bolt for the winch tray. It will say 10.9 on the bolt head. See Figure 15**
17. With help, install the grille guard over the winch tray using supplied M12 hardware. See Figures 16



18. Install Grille Guard to upper support straps using supplied M12 hardware. **See Figures 17**
19. Adjust grille guard and winch tray as needed and torque all M10 hardware to 35-40 ft-lbs., M12 hardware to 60 ft-lbs.



INSTSALL COMPLETE



CARE INSTRUCTIONS

- REGULAR WAXING IS RECOMMENDED. DO NOT USE ANY TYPE OF POLISH OR WAX THAT MAY CONTAIN ABRASIVES.
- STAINLESS STEEL PRODUCTS CAN BE CLEANED WITH MILD SOAP AND WATER. STAINLESS STEEL POLISH SHOULD BE USED TO POLISH SMALL SCRATCHES.
- GLOSS BLACK FINISHES SHOULD BE CLEANED WITH MILD SOAP AND WATER.