

APPLICATION:
2020-2021 Ford F250/350 Super Duty
PART NUMBER:
40-94015, 57-94015

ITEM	QUANTITY	DESCRIPTION	TOOLS NEEDED
1	1	WINCH TRAY	TORQUE WRENCH
2,3	2	LOWER MOUNT BRACKET, DRIVER (2) AND PASSENGER (3)	17MM SOCKET
4,5	2	BUMPER BRACKET, DRIVER (4) AND PASSENGER (5)	19MM SOCKET
6	12	M12 HEX HEAD CAP SCREW (YELLOW ZINC)	18MM SOCKET
7	20	M12 HEX NUT (YELLOW ZINC)	FLAT HEAD SCREW DRIVER
8	20	M12 SPLIT LOCK WASHER (YELLOW ZINC)	
9	32	M12 FLAT WASHER (YELLOW ZINC)	ALLEN WRENCH
10	4	M10 HEX HEAD CAP SCREW (YELLOW ZINC)	SOCKET EXT.
11	4	M10 SPLIT LOCK WASHER (YELLOW ZINC)	RATCHET
12	4	M10 FLAT WASHER (YELLOW ZINC)	
13	4	M12 HEX HEAD CAP SCREW (BLACK ZINC)	
14	4	M12 HEX NUT (BLACK ZINC)	
15	4	M12 SPLIT LOCK WASHER (BLACK ZINC)	
16	8	M12 FLAT WASHER (BLACK ZINC)	
17	1	SPORTSMAN GG (INCLUDED WITH KIT 40-94015)	
18	1	HDX GRILLE GUARD (INCLUDED WITH KIT 57-94015)	
19,20	2	LOWER SUPPORT BRACKET (NOT INCLUDED IN 46-23905)	
21	10	M12 HEX SOCKET BUTTON HEAD SCREW (BLACK ZINC)	
22	10	M12 CUP WASHER (BLACK ZINC)	
23	10	M12 SERRATED FLANGE NUT (BLACK ZINC)	
24	4	M12 HEX HEAD SCREW (BLACK ZINC)	
25	8	M12 FLAT WASHER (YELLOW ZINC)	
26	4	M12 HEX NUT (YELLOW ZINC)	
27	4	M12 SPLIT LOCK WASHER (YELLOW ZINC)	

ANTI-SEIZE LUBRICANT MUST BE USED ON ALL STAINLESS STEEL FASTENERS TO PREVENT THREAD DAMAGE AND GALLING

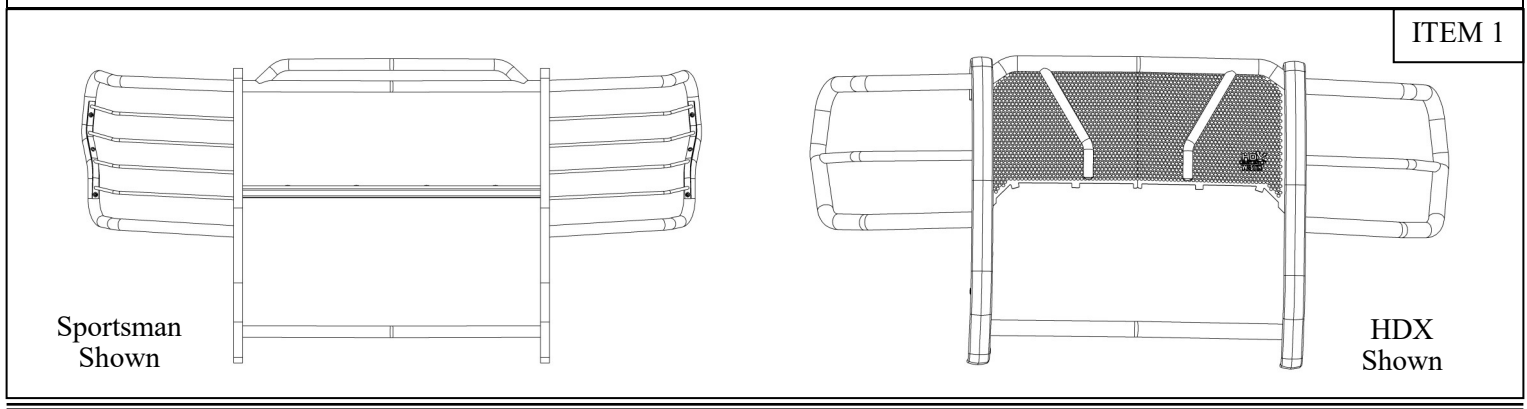

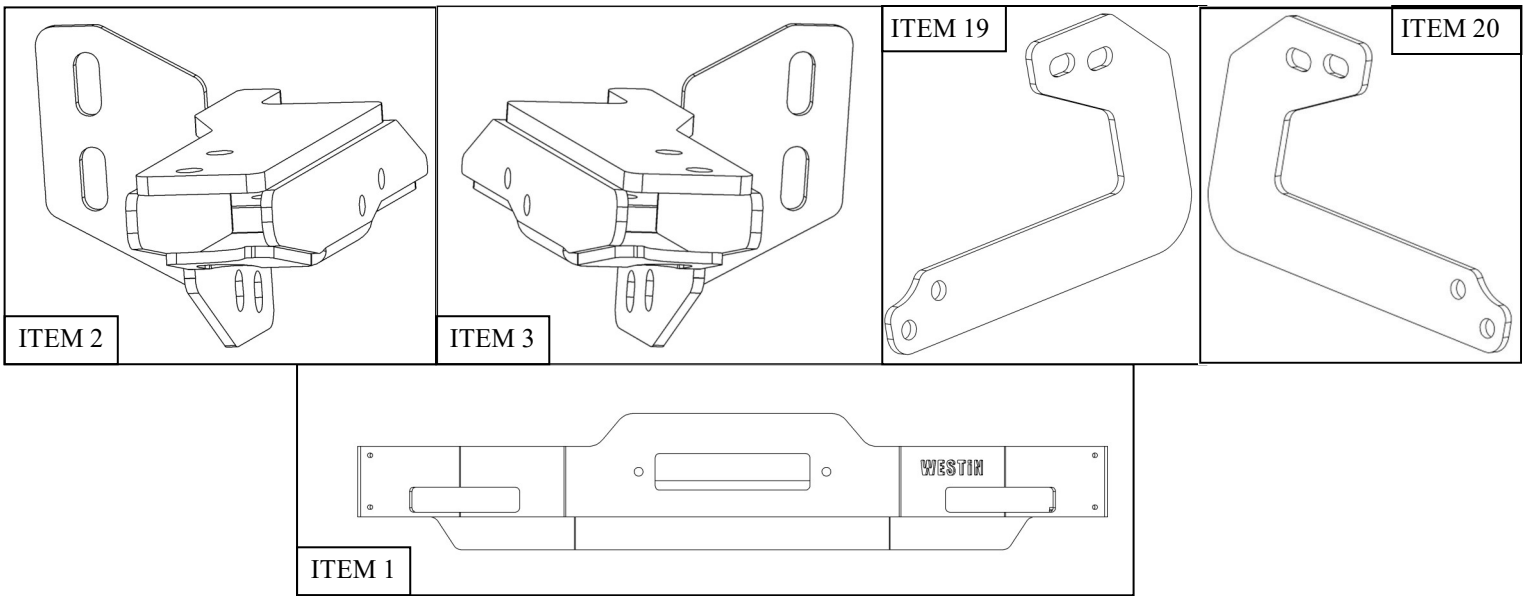

PROCEDURE

1. Remove contents from box, verify if all parts listed are present and free from damage. Carefully read and understand all instructions before attempting installation. **Failure to identify damage before installation could lead to a rejection of any claim.**
2. Starting on either side, use a flathead screw driver to remove the plastic covers located around the factory tow hooks. Repeat for opposite side. Plastic around tow hook must be trimmed in order for bracket to fit through. **See Figures 4 and 5.**

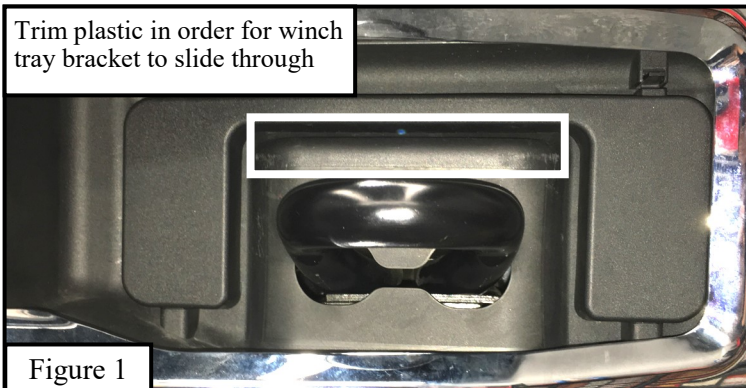

3. Underneath the front of the vehicle locate factory bracket that is attached on the frame and remove the factory hardware. **See Figure 6. Note:** Factory hardware will not be re-used.
4. Re-use the factory hardware from under the plastic cover. **See Figure 7. Note:** Factory nut plates will not be re-used.

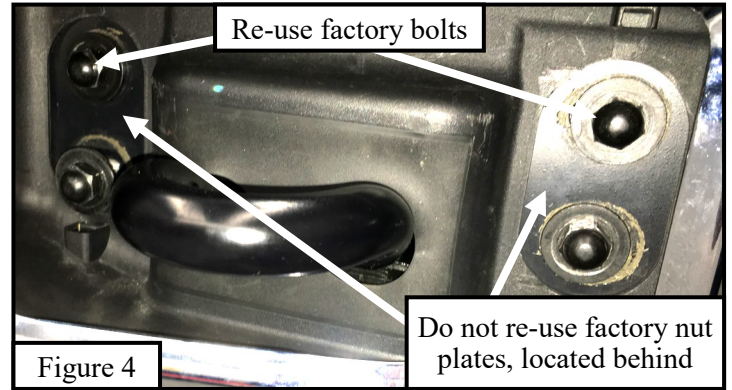

5. Remove bumper by removing (4) bolts on both sides of the vehicle near the front tires and make sure to disconnect any electrical wires. **See Figures 8 and 9.**
6. Remove the factory tow hooks. **Note:** Factory tow hooks will not be re-used. **See Figure 10.**

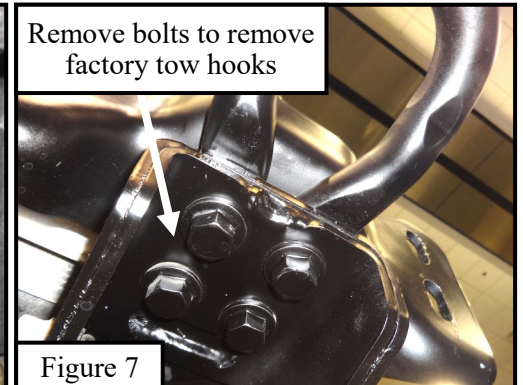
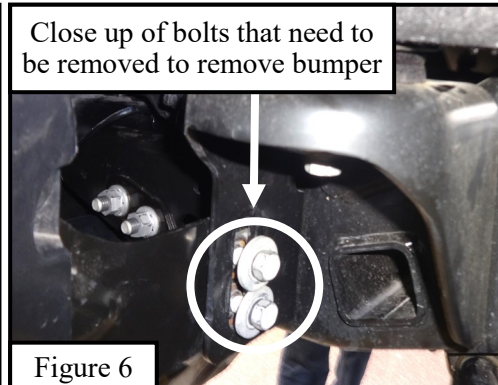
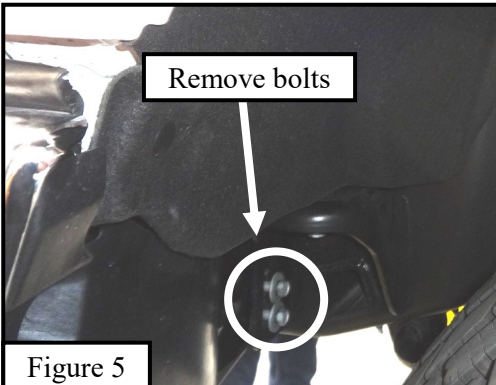

- Starting on either side of the vehicle. Locate (1) Lower Mount Bracket (Item 2/3) and from the front of the vehicle install it where the tow hooks were. Align the bracket with the vehicle frame at the same location that the factory bracket was removed. Loosely install using (4) M12 hex head cap screws, (8) M12 hex nuts, (8) M12 split lock washers and (12) flat washers (Items 6 - 9). See Figures 11 and 12.

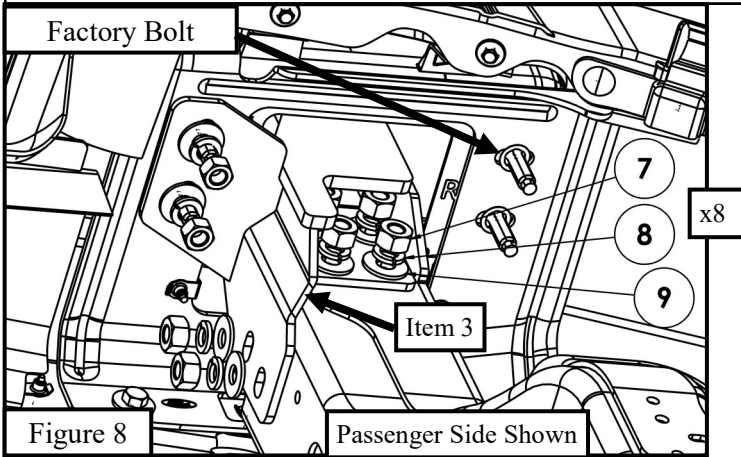

Figure 8

Passenger Side Shown

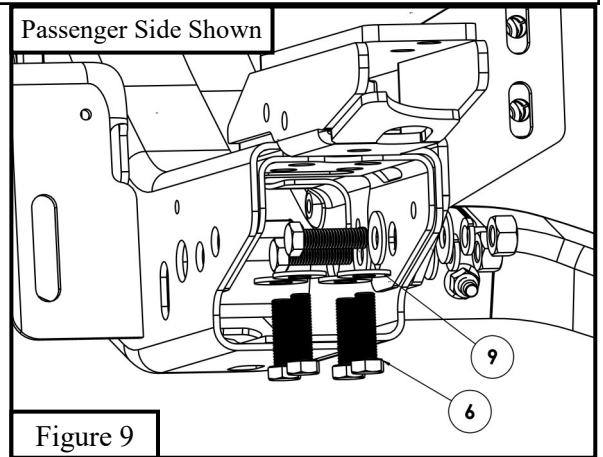

Figure 9

- Locate (1) Bumper Bracket (Item 4/5) and loosely secure onto vehicle frame and Lower Mount Bracket using (2) M10 hex head cap screws, (2) M10 split lock washers, (2) M10 flat washers, (2) M12 flat washers, (2) M12 lock washers, and (2) M12 hex nuts. See Figures 13 and 14.

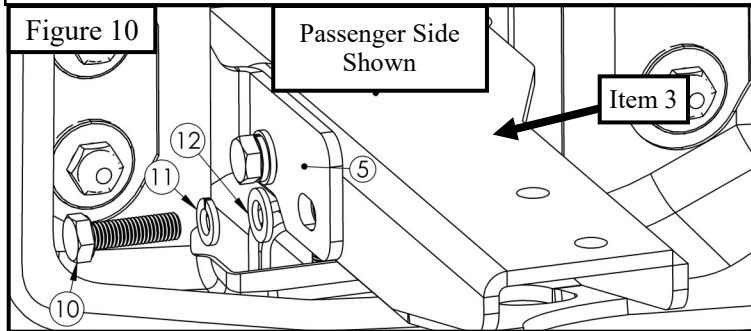

Figure 10

Passenger Side Shown

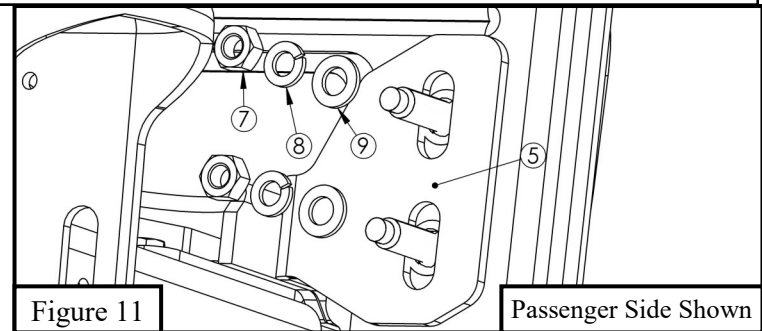

Figure 11

Passenger Side Shown

- Locate (1) Lower Support Bracket (Item 19) and insert through the newly trimmed slots and loosely secure onto vehicle frame using the factory hardware. See Figure 8.
- Repeat Steps 3 - 6 for other side.
- Trimming of lower valence will need to be cut in order to slide the lower bracket through

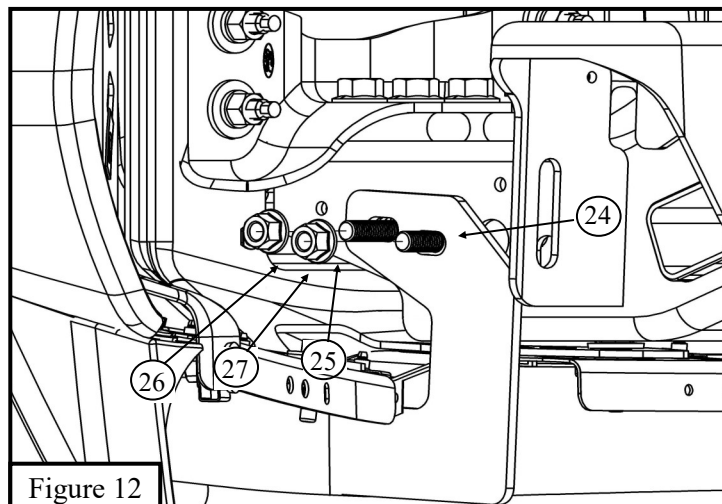

Figure 12

12. Re-install front bumper in the opposite way that they were removed. Re-install the plastic cover where the factory tow hooks were located.
13. Locate (1) Winch Tray (Item 1) and loosely secure onto the Lower Mount Brackets using (4) M12 hex head cap screws, (4) M12 split lock washers, (8) M12 flat washers, and (4) M12 hex nuts. See **Figure 17**.
14. Locate (1) HDX/Sportsman Grille Guard (Items 17/18) and with assistance align it with the previously installed brackets and loosely secure using (6) M12 hex socket button head screws, (6) M12 cup washers, (6) M12 serrated flange nuts, (2) M10 hex socket button head screws, (2) M10 cup washers, and (2) M10 serrated flange nuts. See **Figure 18**.

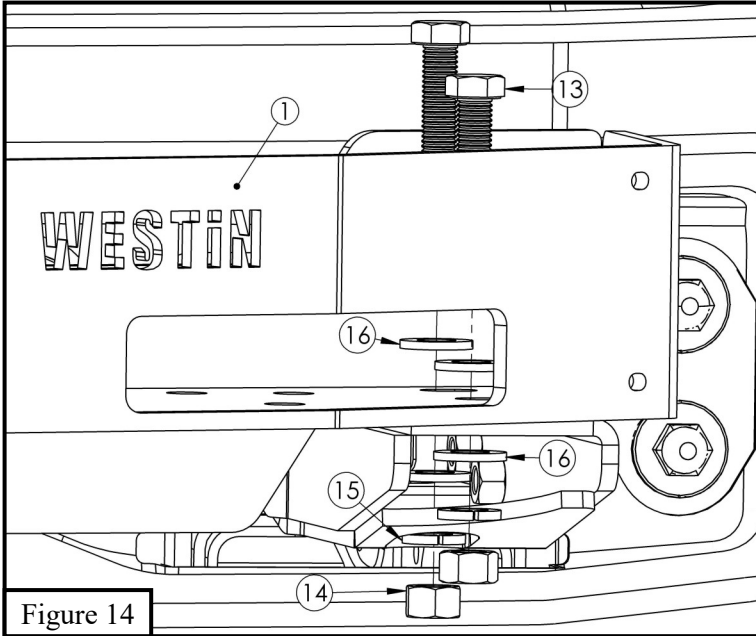

Figure 14

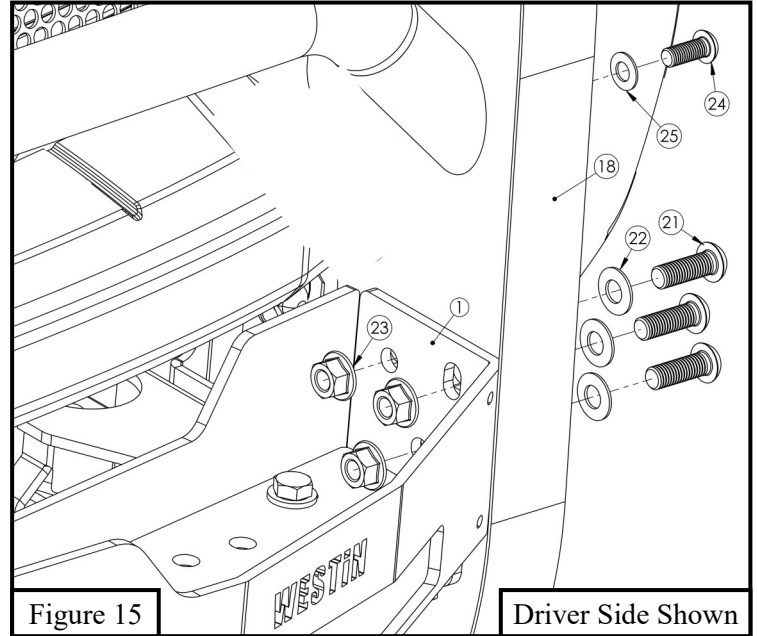

Figure 15

Driver Side Shown

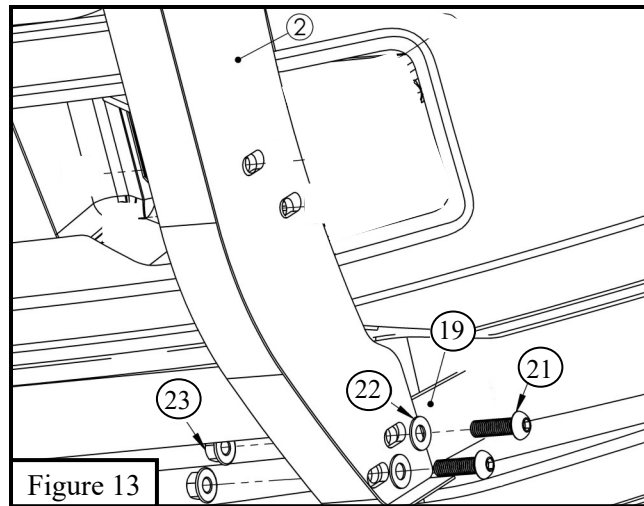

Figure 13

15. Align and adjust the grille guard and brackets as necessary and then torque all: M10 hardware to 30-35 ft-lbs, and M12 to 50-55 ft-lbs.

INSTALLATION COMPLETE



CARE INSTRUCTIONS

- REGULAR WAXING IS RECOMMENDED. DO NOT USE ANY TYPE OF POLISH OR WAX THAT MAY CONTAIN ABRASIVES.
- STAINLESS STEEL PRODUCTS CAN BE CLEANED WITH MILD SOAP AND WATER. STAINLESS STEEL POLISH SHOULD BE USED TO POLISH SMALL SCRATCHES.
- GLOSS BLACK FINISHES SHOULD BE CLEANED WITH MILD SOAP AND WATER.

WESTIN