

INSTALLATION INSTRUCTIONS

HDX Grille Guard



APPLICATION:
2020 Chevrolet Silverado 2500/3500
PART NUMBER:
57-3990, 57-3995

ITEM	QUANTITY	DESCRIPTION	TOOLS NEEDED
1	1	GRILLE GUARD	RATCHET
2	1	LOWER DRIVER MOUNTING BRACKET	16mm SOCKET
3	1	LOWER PASSENGER MOUNTING BRACKET	17mm SOCKET
4	1	DRIVER INSIDE SUPPORT BRACKET	18mm SOCKET
5	1	PASSENGER INSIDE SUPPORT BRACKET	16mm WRENCH
6	1	DRIVER UPPER STRAP	17mm WRENCH
7	1	PASSENGER UPPER STRAP	18mm WRENCH
8	2	SHORT M12 HEX HEAD BOLT (YELLOW ZINC)	TORQUE WRENCH
9	4	LONG M12 HEX HAD BOLT (YELLOW ZINC)	CUTTING TOOL
10	6	M12 SPLIT LOCK WASHER (YELLOW ZINC)	
11	12	M12 FLAT WASHER (YELLOW ZINC)	
12	6	M12 HEX NUT (YELLOW ZINC)	
13	2	M10 BUTTON HEAD BOLT	
14	2	M10 BELLVILLE WASHER	
15	2	M10 SERRATED FLANGE NUT	
16	6	M12 BUTTON HEAD BOLT	
17	6	M12 SERRATED FLANGE NUT	
18	6	M12 BELLVILLE WASHER	

ANTI-SEIZE LUBRICANT MUST BE USED ON ALL STAINLESS STEEL FASTENERS TO PREVENT THREAD DAMAGE AND GALLING.

CUTTING TEMPLTE INCLUDED SEE PAGE 4

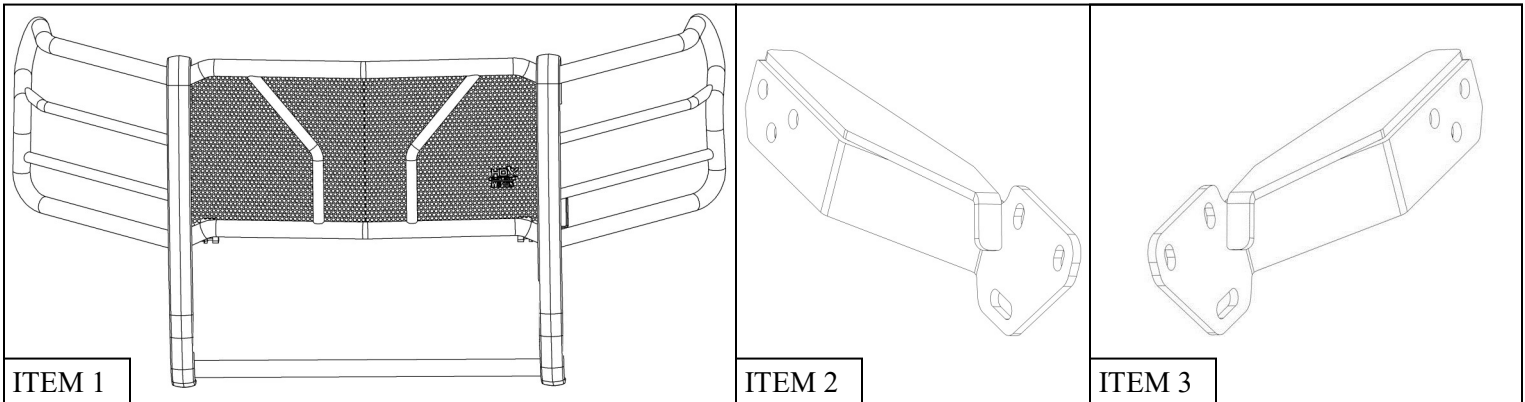

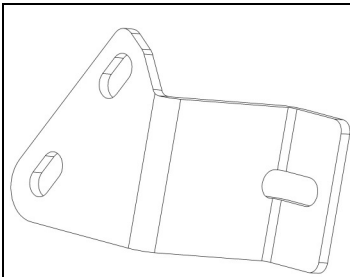

ITEM 4

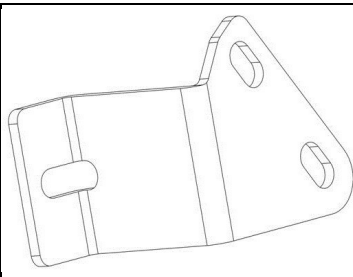

ITEM 5

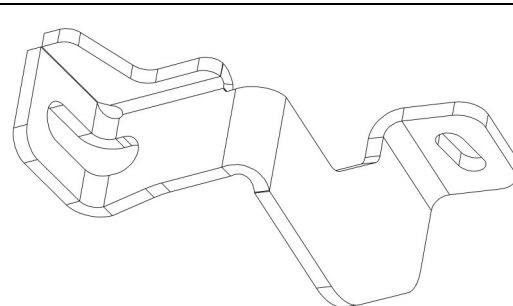

ITEM 6

ITEM 7

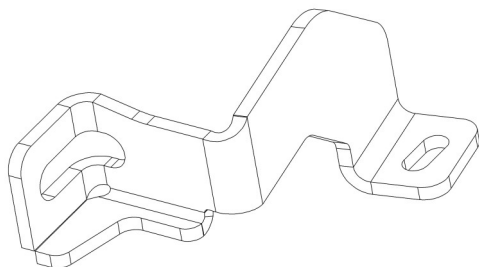

PROCEDURE

1. Remove contents from box, verify if all parts listed are present and free from damage. Carefully read and understand all instructions before attempting installation.
Failure to identify damage before installation could lead to a rejection of any claim.
2. Open the hood of the vehicle and remove the plastic cover at the front using a pry tool. See **Figure 1**.
3. Remove the four bolts holding the grille in place. See **Figure 2**.
4. Remove 2 bolts attaching wheel well cover to filler panel. See **Figure 3**.



Fig. 1

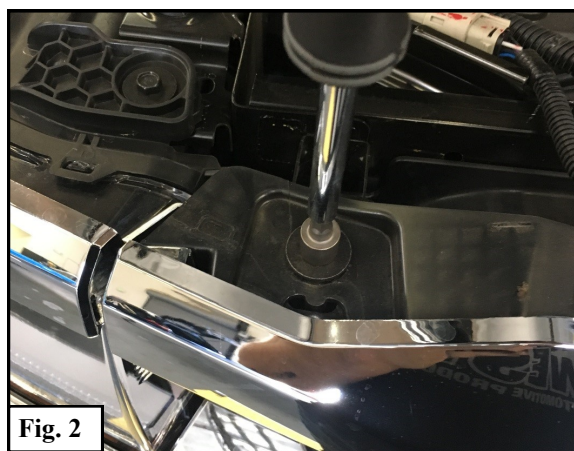

Fig. 2



Fig. 3

5. Pry off fenders to access the filler panel clips. See **Figure 4**.
6. Pry filler panel off removing any necessary bolts. See **Figure 5**.
7. Disconnect any electrical plugs and any bolts still attaching the grill to the vehicle. See **Figure 6**.
8. Pry remaining clips attaching the grill to the vehicle to remove the grille.

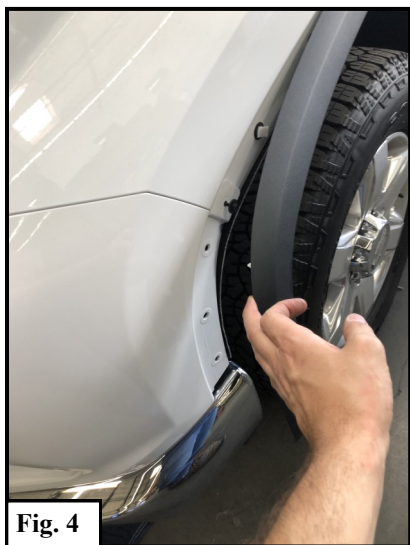

Fig. 4

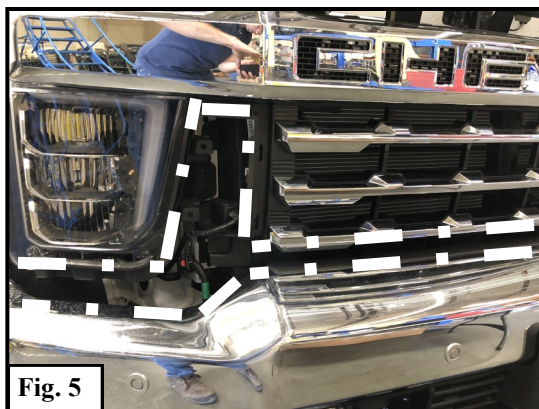

Fig. 5

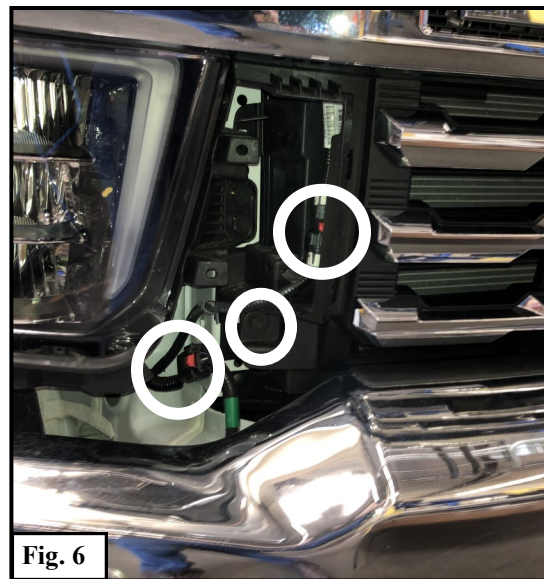

Fig. 6

9. Remove 4 upper bumper bolts attaching the bumper to the frame and remove 2 bottom bolts attaching bumper arm to the frame. See **Figure 7 & 8**.
10. **Remove Bumper.**

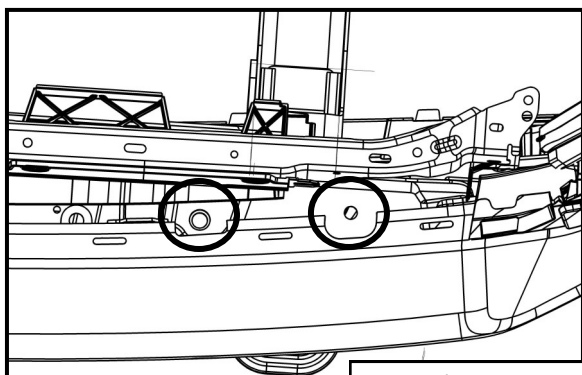

Fig. 7

Bolts will be exposed after removing the grille and lifting the plastic covering them

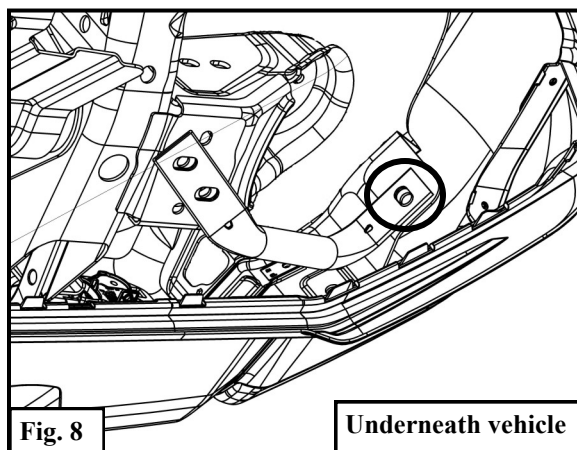
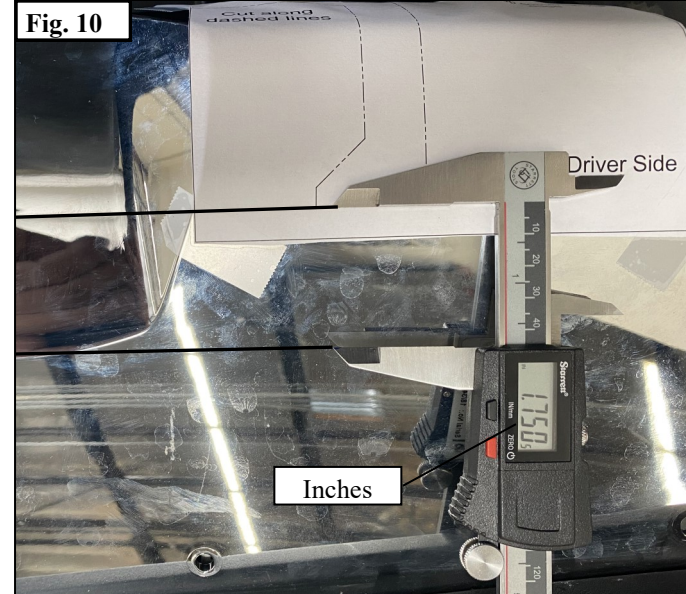
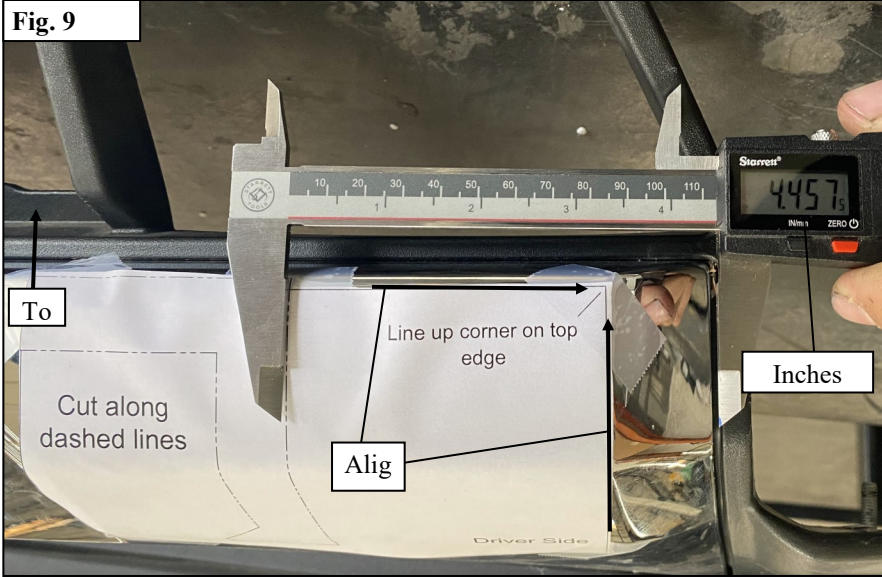

Fig. 8

Underneath vehicle

11. Locate the driver and passenger cutting templates (22-23). Starting on either side, along the template to the top corner of the valence. **See Figure 9.** Tape the template to the valence.
12. Using **Figures 9-10**, ensure that the measurements match your template. Follow the template instructions and cut accordingly. **Note: After cutting, you will still need to adjust your brackets and more cutting may be required!**



13. Locate the lower driver mounting and support brackets for the Grille Guard. Using the supplied M12 hardware, loosely install the mounting brackets on to the frame. The mounting bracket and support bracket (5) sandwich the frame. **See Figure 11-12.**
14. Repeat on the passenger side.

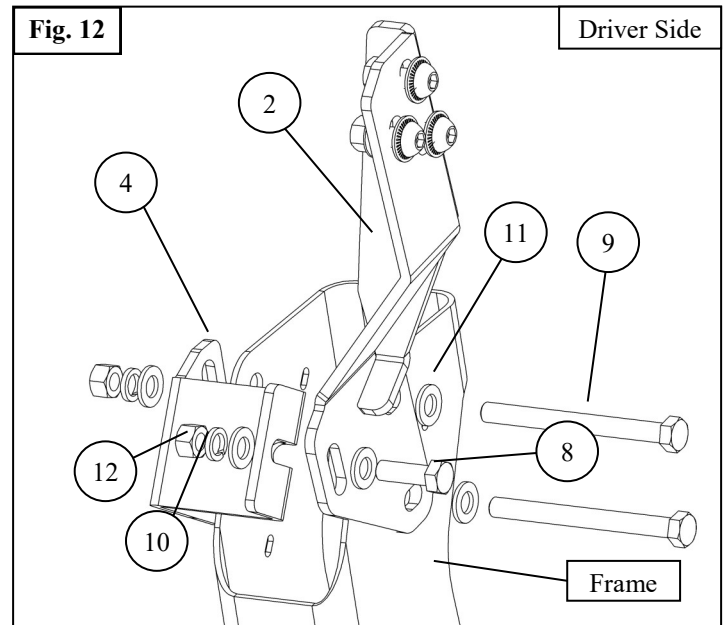
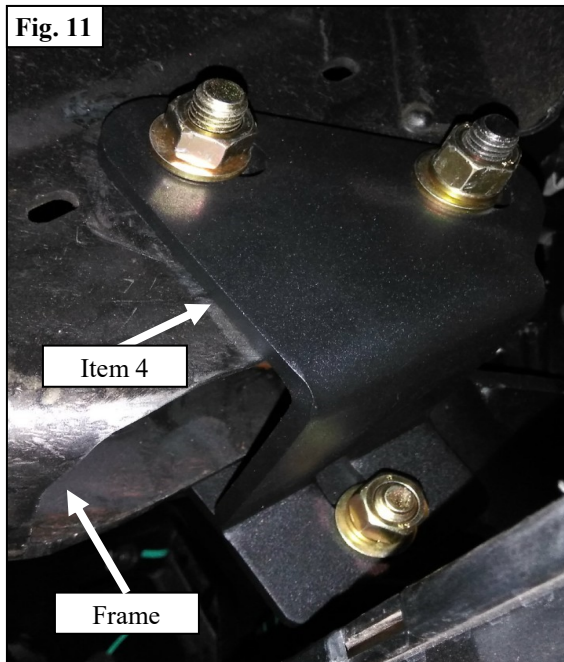

15. Locate the upper support straps (6-7) for the Grille Guard. Loosely re-install the front bumper with the upper support straps. Reconnect all electrical connections. The upper factory bumper bolts will be used for the upper support straps. Measure the distance between the mounting surfaces of the upper straps and ensure it is about 42.25". Torque to 50-55 ft-lbs. See **Figure 13-14**.

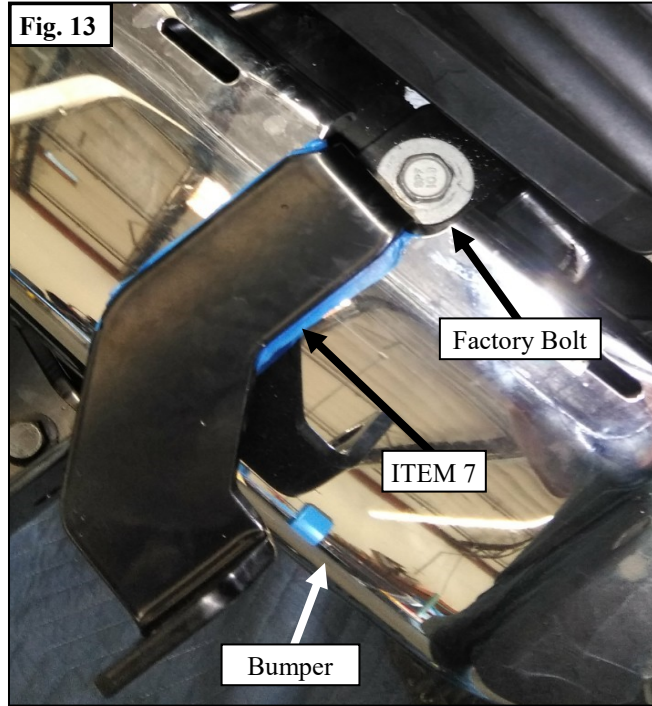
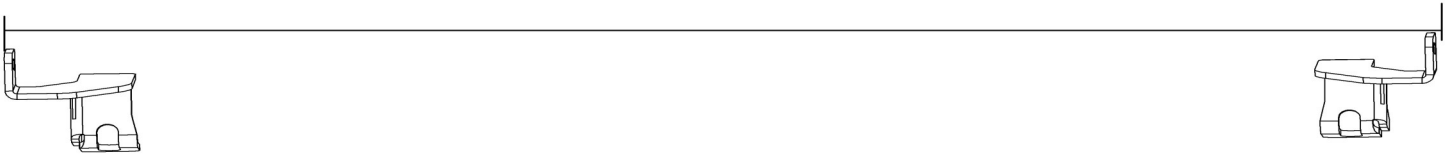

Fig. 14

42.25 inches



16. REINSTALL FILLER PANEL AND GRILLE IN REVERSE ORDER AS INSTRUCTED.

17. With help, install the Grille Guard over the lower mount brackets and previously installed upper support brackets. Using the supplied M10 and M12 hardware. See **Figures 15-16**.
 18. Align as necessary and torque all hardware as specified: M12 to 50-55 ft-lbs., M10 to 30-35 ft-lbs.

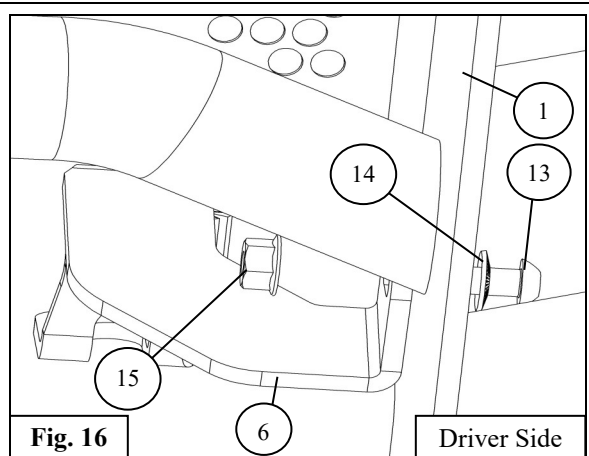
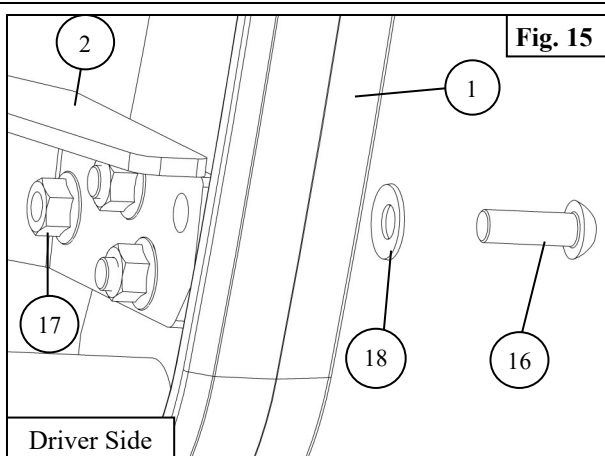

INSTALL COMPLETE



CARE INSTRUCTIONS

- REGULAR WAXING IS RECOMMENDED. DO NOT USE ANY TYPE OF POLISH OR WAX THAT MAY CONTAIN ABRASIVES.
- STAINLESS STEEL PRODUCTS CAN BE CLEANED WITH MILD SOAP AND WATER. STAINLESS STEEL POLISH SHOULD BE USED TO POLISH SMALL SCRATCHES.
- GLOSS BLACK FINISHES SHOULD BE CLEANED WITH MILD SOAP AND WATER.

WESTiN