



SIGNATURE OF QUALITY

AUTOMOTIVE PRODUCTS, INC.

# INSTRUCTIONS

APPLICATION: 2015 CHEVY SILVERADO 2500/3500  
HDX AND SPORTSMAN GRILLE GUARDS  
APPLICATION PART #'S 45-3780, 40-3785, 57-3780, 57-3785

ITEM	QUANTITY	DESCRIPTION	TOOLS NEEDED
1	1	GRILLE GUARD	RATCHET
2,3	2	LOWER MOUNTING BRACKETS (DRV & PASS)	SCREWDRIVER
4,5	2	SUPPORT STRAPS (DRV & PASS)	15MM WRENCH
6	4	M12 FLANGE BOLT	15MM SOCKET
7	4	M12 FLANGE NUT	ALLEN WRENCH
8	8	M10 STAINLESS BUTTON HEAD BOLT	18MM WRENCH
9	8	M10 STAINLESS CUPPED WASHER	18MM SOCKET
10	8	M10 STAINLESS FLANGE NUT	10MM SOCKET
			16MM SOCKET
			16MM WRENCH
			RATCHET EXT.
			TORQUE WRENCH

### ANTI-SEIZE LUBRICANT MUST BE USED ON ALL STAINLESS STEEL FASTENERS TO PREVENT THREAD DAMAGE AND GALLING

1. Remove contents from box, verify if all parts listed are present and free from damage. Carefully read and understand all instructions before attempting installation.
2. Remove the factory tow hooks (if equipped). They can be re-used with this kit if desired. Refer to Figure 1.
3. Slip the Lower Mounting Brackets through the tow hook pockets one side at a time. Position them as shown in Figure 2.
4. Insert the factory tow hooks back into their original locations. Note: Skip this step if tow hooks are not available or desired.

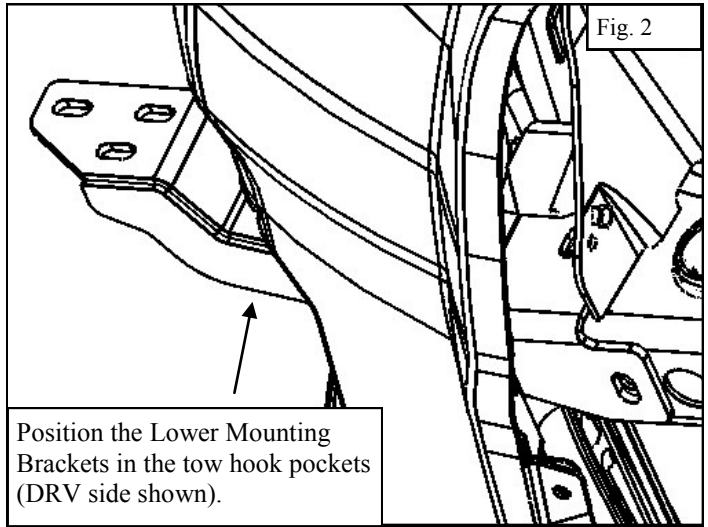
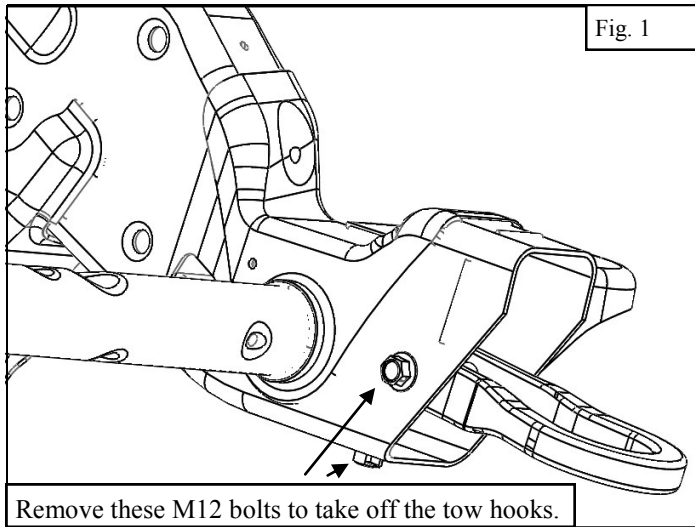

Thank You for choosing Westin products.

5. Loosely attach the Lower Mounting Brackets to the vehicle's frame and tow hooks using the factory hardware as shown in Figure 3. Note: If the tow hooks are not being used then use the supplied M12 Flange Bolts and Nuts instead.
6. Remove the vehicle's radiator cover as shown in Figure 4.

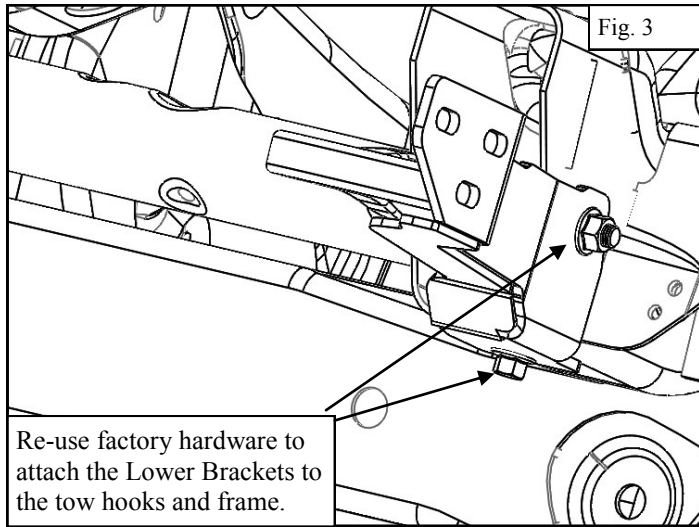

7. Remove the vehicle's grille as shown in Figure 5.
8. Remove the upper factory bumper bolts as shown in Figure 6.

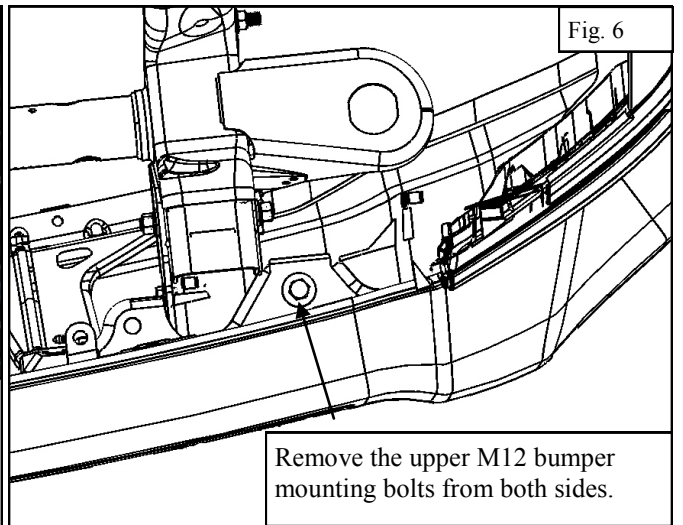
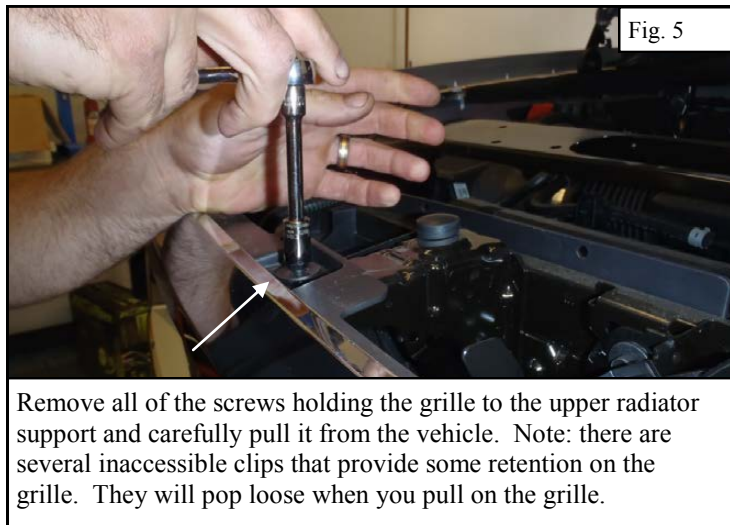

9. Loosely attach the Support Straps to the locations where the bumper bolts were previously removed using the factory hardware.
10. Center the support straps, adjust them to 42-3/4" from outer flange to outer flange and tighten and torque them to 50-55 ft-lbs. Refer to Figure 7.
11. Reinstall the vehicle's grille and radiator cover in the reverse order that they were removed. Note: The bottom of the grille may need to be squeezed past the Support Straps.

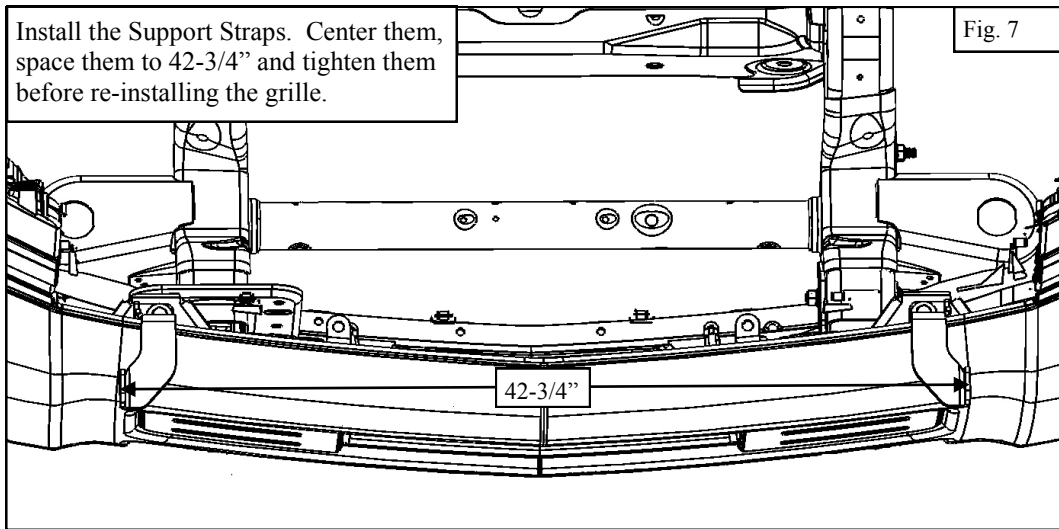

12. With assistance loosely install the Grille Guard using M10 Button Head fasteners as shown in Figure 8.
13. Align and adjust the Grille Guard as necessary then tighten and torque all remaining hardware: M10 to 30-35 ft-lbs.; M12 to 50-55 ft-lbs.

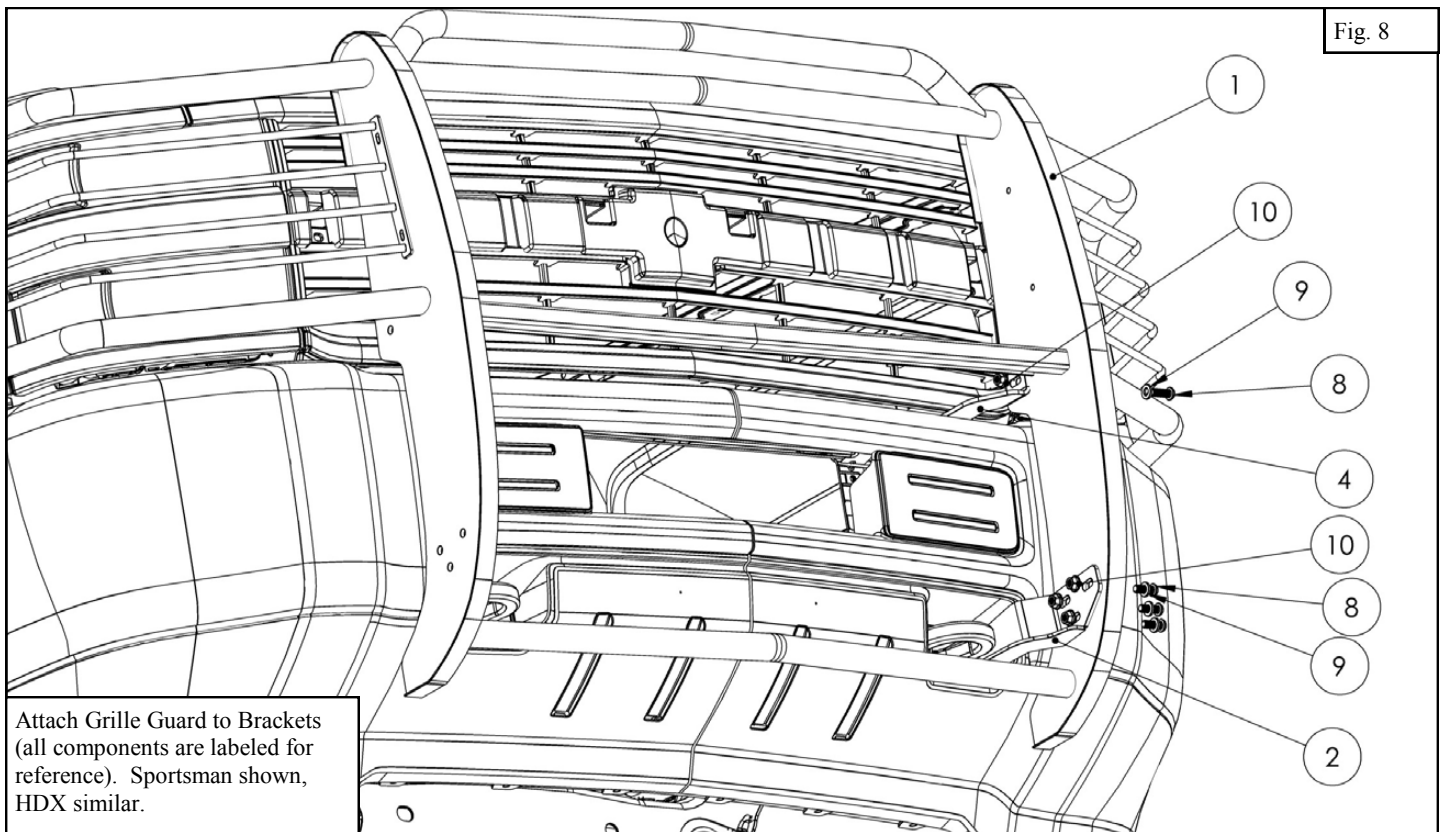

**CARE INSTRUCTIONS**

- REGULAR WAXING IS RECOMMENDED. DO NOT USE ANY TYPE OF POLISH OR WAX THAT MAY CONTAIN ABRASIVES.
- STAINLESS STEEL PRODUCTS CAN BE CLEANED WITH MILD SOAP AND WATER. STAINLESS STEEL POLISH SHOULD BE USED TO POLISH SMALL SCRATCHES.
- GLOSS BLACK FINISHES SHOULD BE CLEANED WITH MILD SOAP AND WATER.



Thank You for choosing Westin products.

SPORTSMAN GRILLE GUARD, INSTALLATION COMPLETE



HDX GRILLE GUARD, INSTALLATION COMPLETE

