

## INSTALLATION INSTRUCTIONS

### HDX DROP W2W NERF STEP BARS

**APPLICATION:**

2020 Chevrolet/GMC Silverado/Sierra 2500/3500 Crew Cab 6.5' and 8' bed

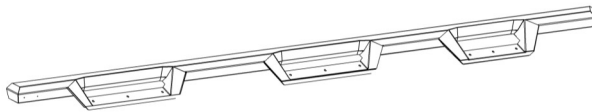
**PART NUMBER:** 56-534775, 56-5347752, 56-534765, 56-5347652

ITEM	QUANTITY	DESCRIPTION	TOOLS NEEDED
1	2	STEP BAR ASSEMBLY DRIVER AND PASSENGER	RATCHET
2,3	2	CENTER MOUNT BRACKET, DRIVER (2) AND PASSENGER (3)	TORQUE WRENCH
4	4	MOUNTING BRACKET	SOCKET EXT.
5	18	M8 HEX HEAD BOLT LONG (YELLOW ZINC)	13MM SOCKET
6	12	M8 HEX HEAD BOLT SHORT (YELLOW ZINC)	13MM WRENCH
7	32	M8 FLAT WASHER (YELLOW ZINC)	18MM SOCKET
8	32	M8 LOCK WASHER (YELLOW ZINC)	18MM WRENCH
9	2	M12 ISOLATOR KIT	
10, 11	2	TOP ISOLATOR BRACKET, DRIVER (10) AND PASSENGER (11)	
12, 13	2	BOTTOM ISOLATOR BRACKET, DRIVER (12) AND PASSENGER (13)	
14	4	ISOLATOR KIT	
15	2	M8 HEX NUT	

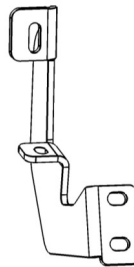
**ANTI-SEIZE LUBRICANT MUST BE USED ON ALL STAINLESS STEEL FASTENERS TO PREVENT THREAD DAMAGE AND GALLING**

Driver Side Shown

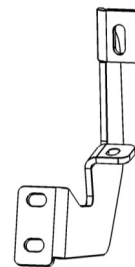
8 ft. Bed Shown



ITEM 1



ITEM 2

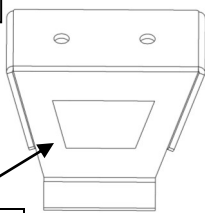


ITEM 3



ITEM 4

ITEM 10



Note  
Asymmetric

ITEM 12



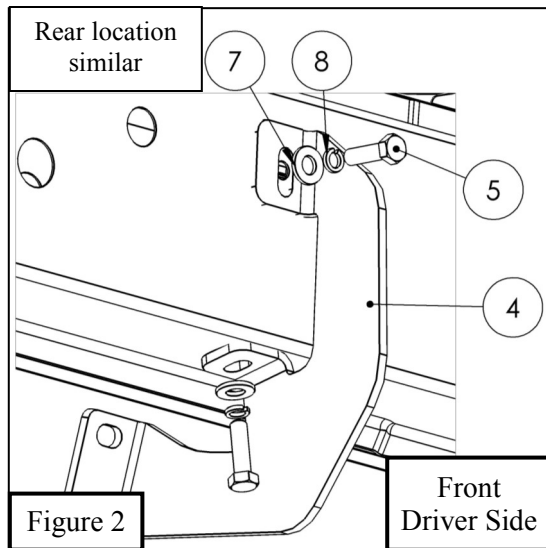
### PROCEDURE

1. Remove contents from box, verify if all parts listed are present and free from damage.  
Carefully read and understand all instructions before attempting installation.  
**Failure to identify damage before installation could lead to a rejection of any claim.**

2. Starting on the driver side, remove the rubber plugs located on the rocker panel at each mounting location. See **Figure 1**.
3. **For models with threaded holes:** At each bracket mounting location on the rocker panel there should be a welded factory nut.

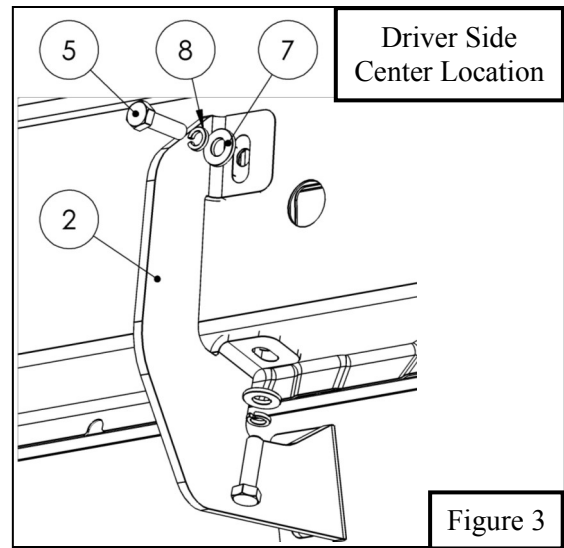


**Fig. 1**



**Figure 2**

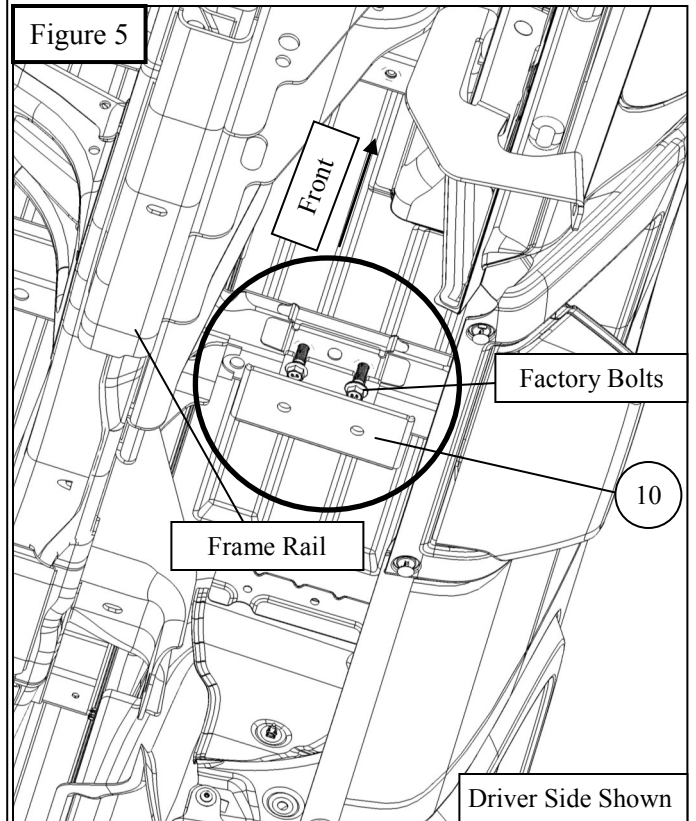
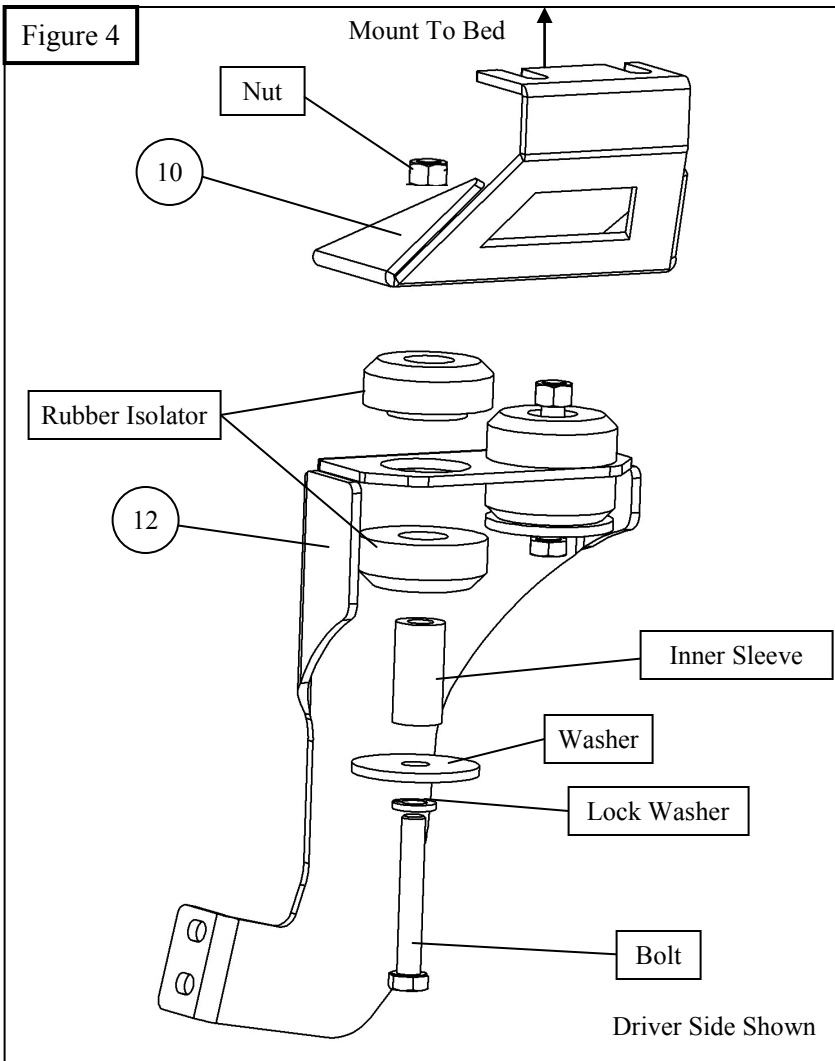
**Front  
Driver Side**



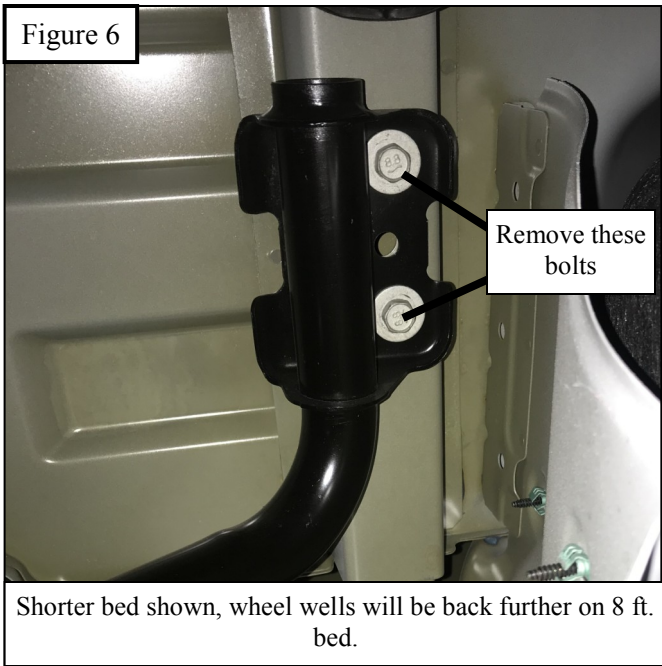
**Figure 3**

4. Locate (1) Center Mount Bracket (Item 2-3). Loosely secure Center Mount Bracket to the rocker panel using (2) M8 hex head bolt long, (2) M8 flat washer, and (2) M8 lock washer. See **Figure 3**. Refer to **Page 4** bracket orientation figures.

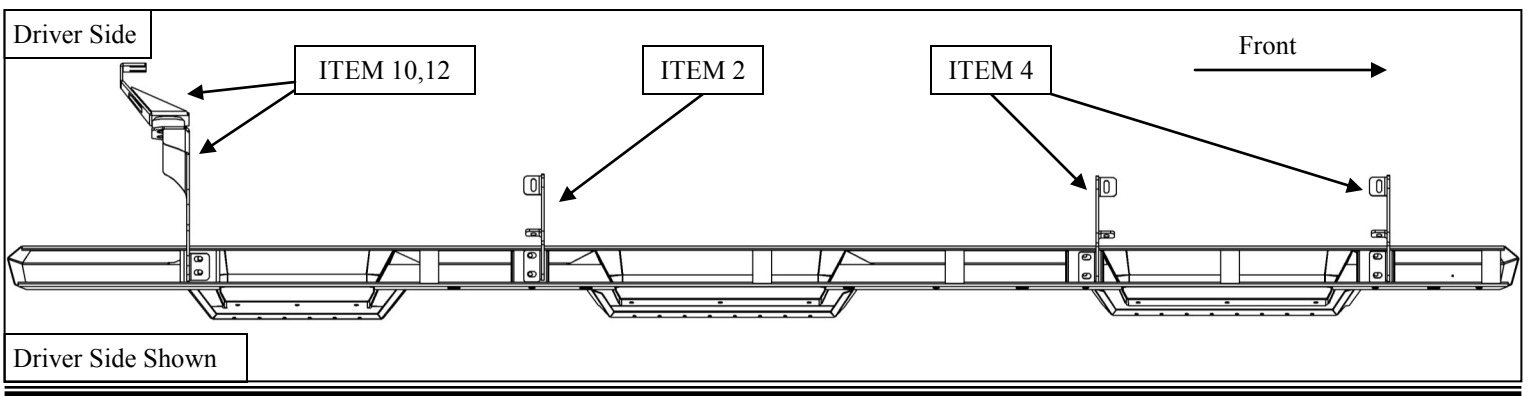
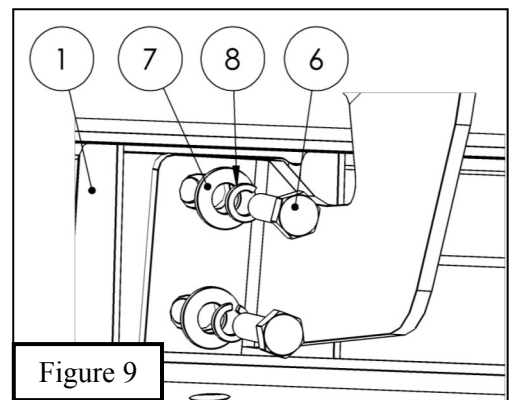
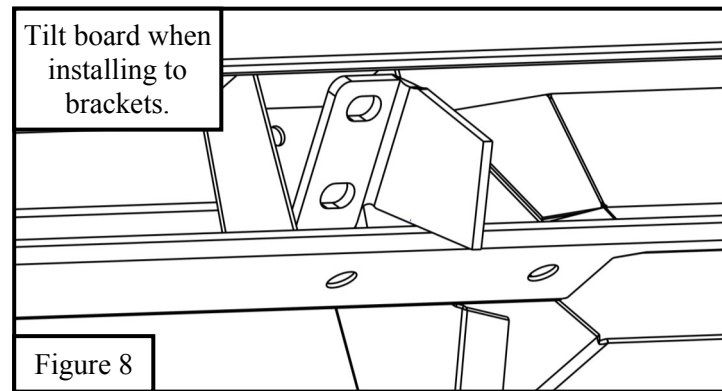
5. Attach the Bottom Isolator Bracket (12) to the Top Isolator Bracket (10) using the Isolator Kit (9) hardware. See **Figure 4**.



6. Under the front of the bed, there is two factory bolts as shown in **Figure 5**. Remove these bolts.
7. Using Preexisting factory bolts, mount the isolator bracket assembly (10) in between the bed and factory bed bracket. See **Figures 5-7**



8. For Step Board installation, tilt board at an angle to insert brackets into mounting locations. With the previously installed mounting brackets use the supplied M8 hardware with the short M8 hex head bolt, then loosely install. See **Figures 8 & 9**.
9. Align and adjust the step bars and brackets as needed, then fully tighten all hardware: M8 to 15-18 ft-lbs.



INSTALLATION COMPLETE



### Care Instructions

- REGULAR WAXING IS RECOMMENDED. DO NOT USE ANY TYPE OF POLISH OR WAX THAT MAY CONTAIN ABRASIVES.
- STAINLESS STEEL PRODUCTS CAN BE CLEANED WITH MILD SOAP AND WATER. STAINLESS STEEL POLISH SHOULD BE USED TO POLISH SMALL SCRATCHES.
- GLOSS BLACK FINISHES SHOULD BE CLEANED WITH MILD SOAP AND WATER.

**WESTIN**