



INSTALLATION INSTRUCTIONS

HDX DROP STEP WHEEL-TO-WHEEL NERF STEP BARS

APPLICATION:

Ram 1500 Crew Cab 2019 (5.5 ft. Bed) (Excl. 2019 Ram 1500 Classic); Ram 1500 Crew Cab & Quad Cab 2019 (6.4 ft. Bed) (Excl. 2019 Ram 1500 Classic)

PART NUMBER:

56-534705, 56-5347052, 56-534725, 56-5347252, 56-534735, 56-5347352

CONTENT			
ITEM	QUANTITY	DESCRIPTION	TOOLS NEEDED
1	2	RUNNING BOARD ASSEMBLY (1 DRIVER, 1 PASSENGER)	16MM SOCKET
2	2	FRONT MOUNTING BRACKET (1 DRIVER, 1 PASSENGER)	16MM WRENCH
3	2	CENTER MOUNTING BRACKET	13MM SOCKET
4	2	REAR MOUNTING BRACKET	13MM WRENCH
5	6	MOUNTING BRACKET BASE	10MM SOCKET
6	2	TOP ISOLATOR BRACKET (1 DRIVER, 1 PASSENGER)	10MM WRENCH
7	2	TOP ISOLATOR BRACE (1 DRIVER, 1 PASSENGER)	15MM SOCKET
8	2	BOTTOM ISOLATOR BRACKET (1 DRIVER, 1 PASSENGER)	19MM SOCKET
9	4	ISOLATOR KIT	1/2" EXTENSION
10	16	M8 HEX HEAD BOLT (YELLOW ZINC)	RATCHET
11	38	M8 SPLIT LOCK WASHER (YELLOW ZINC)	TORQUE WRENCH
12	38	M8 FLAT WASHER (YELLOW ZINC)	IMPACT GUN
13	24	M8 HEX NUT (YELLOW ZINC)	BREAKER BAR
14	2	M10 HEX HEAD BOLT (YELLOW ZINC)	
15	2	M10 SPLIT LOCK WASHER (YELLOW ZINC)	
16	4	M10 FLAT WASHER (YELLOW ZINC)	
17	2	M10 HEX NUT (YELLOW ZINC)	
18	4	M12 HEX HEAD BOLT (YELLOW ZINC)	
19	4	M12 SPLIT LOCK WASHER (YELLOW ZINC)	
20	6	M8 ROUND HEAD SQUARE NECK BOLT (BLACK ZINC)	
21	18	M8 PLASTIC RETAINER SQUARES	

ANTI-SEIZE LUBRICANT MUST BE USED ON ALL STAINLESS STEEL FASTENERS TO PREVENT THREAD DAMAGE AND GALLING



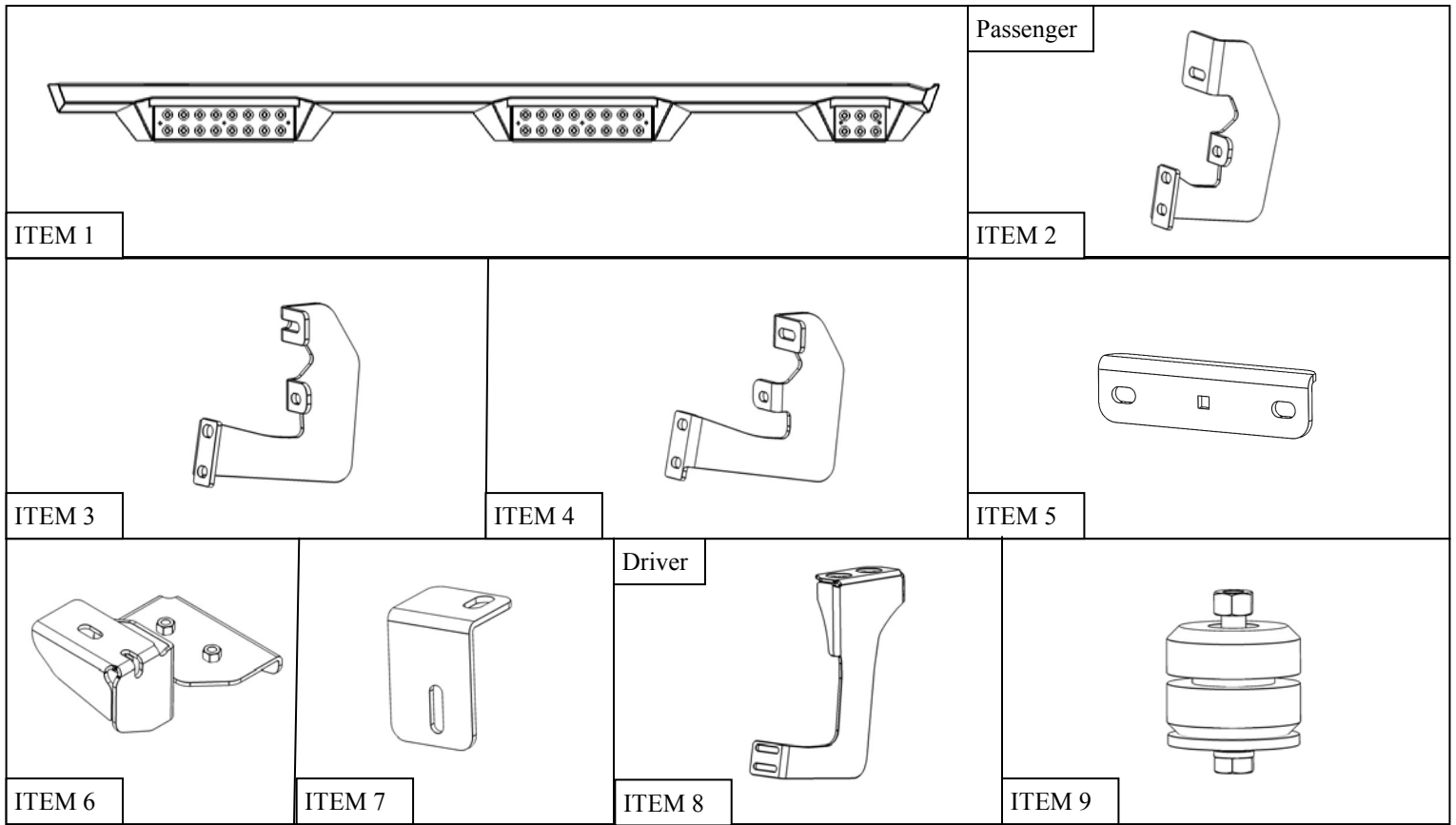

PROCEDURE

- Remove contents from box, verify if all parts listed are present and free from damage. Carefully read and understand all instructions before attempting installation.
Failure to identify damage before installation could lead to a rejection of any claim.
- Preassemble the Mounting Brackets with Mounting Bracket Bases. Do not tighten hardware at this time. See **Figure 1**.

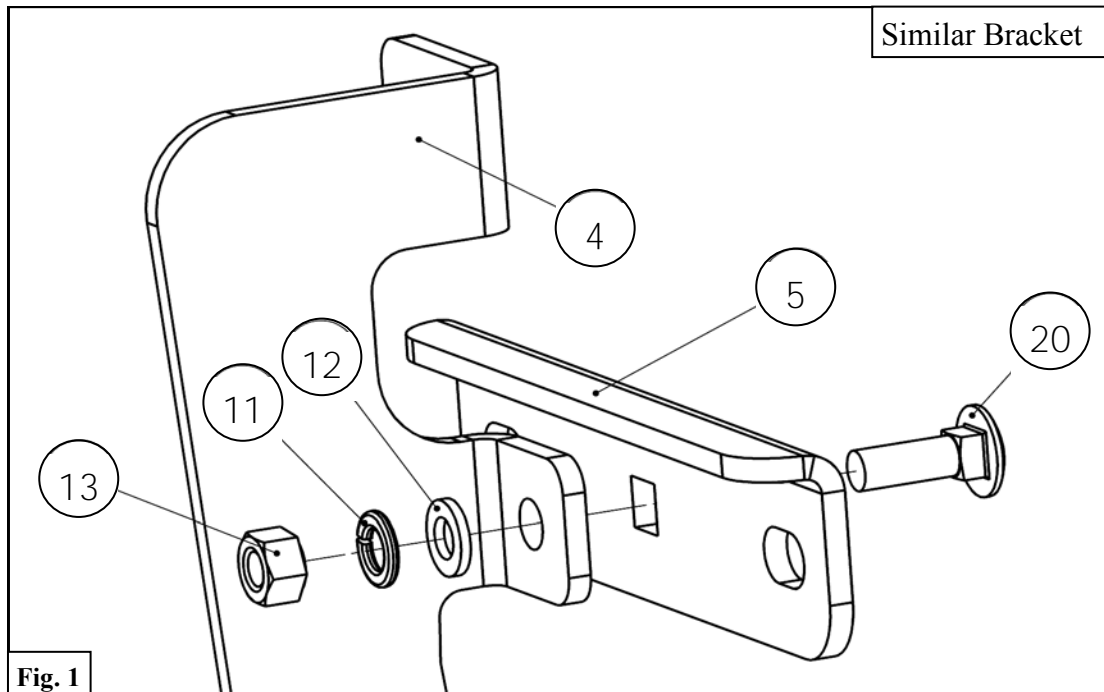

3. Starting on the passenger side of the vehicle, locate the 3 mounting locations on the rocker panel.

Note A: The rear mounting location is shown in **Figure 2**.

Other mounting locations are similar.

Note B: The lower two studs on the rocker panel have a thick coat of paint on them. When installing the M8 hex nuts, apply extra pressure to start. If necessary, back M8 hex nuts off the studs to clear build up.

See **Figure 2**.

Rear Mounting Location Shown
Other Mounting Locations are Similar

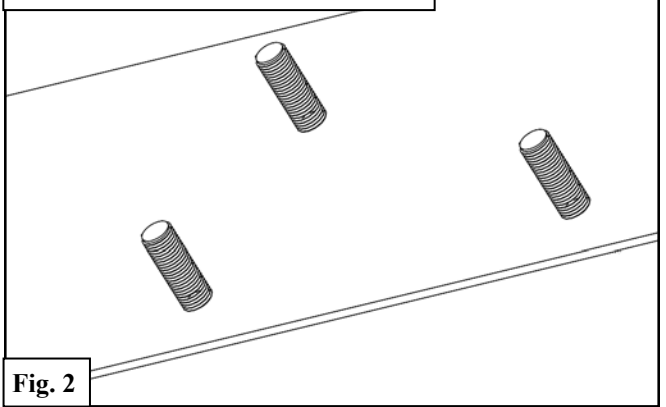

4. At the rear mounting location, loosely install Rear Mounting Bracket (4) with preassembled Mounting Bracket Base (5) using the supplied M8 hardware. See **Figures 3 & 4**.

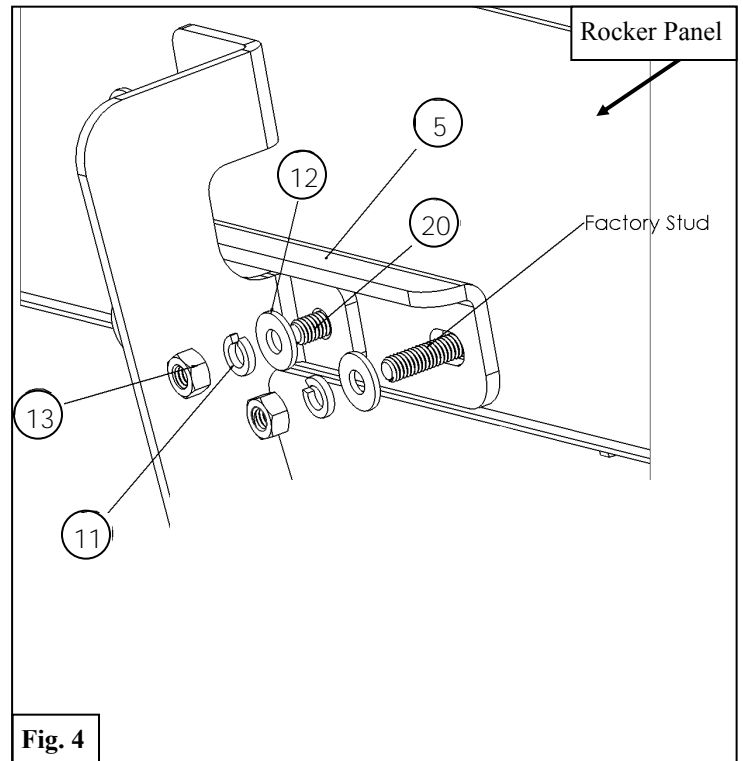
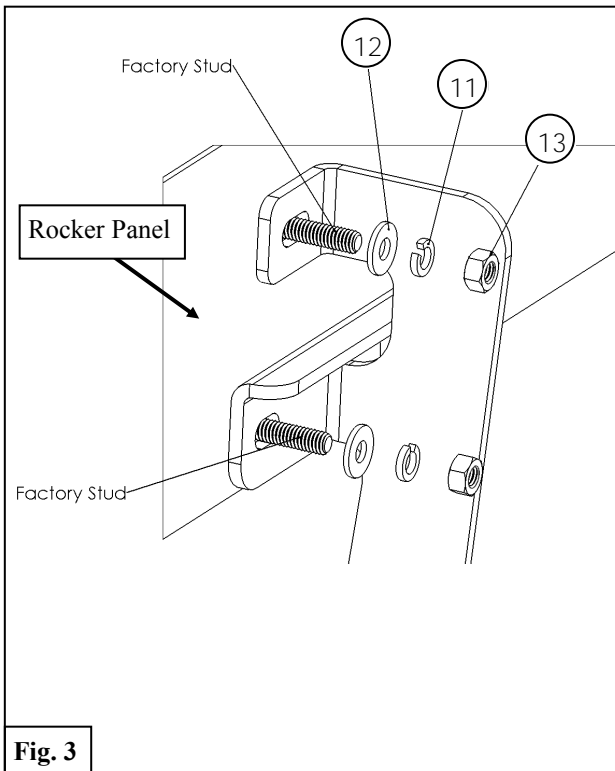

5. At the center mounting location, loosely install Center Mounting Bracket (3) with preassembled Mounting Bracket Base (5) using the supplied M8 hardware. See **Figures 5 & 6**.

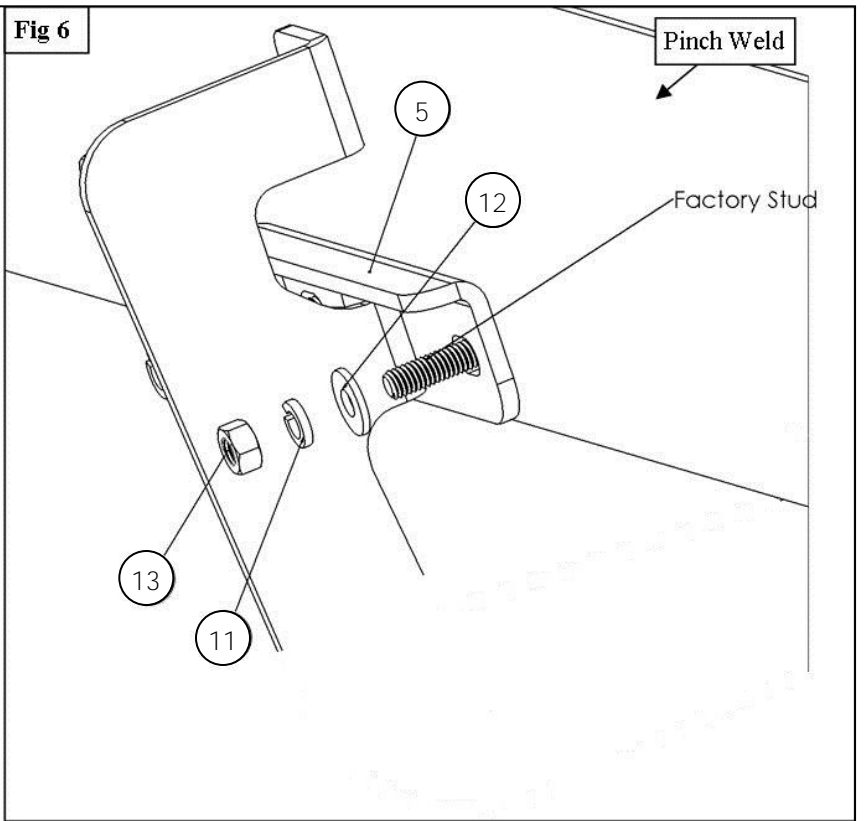
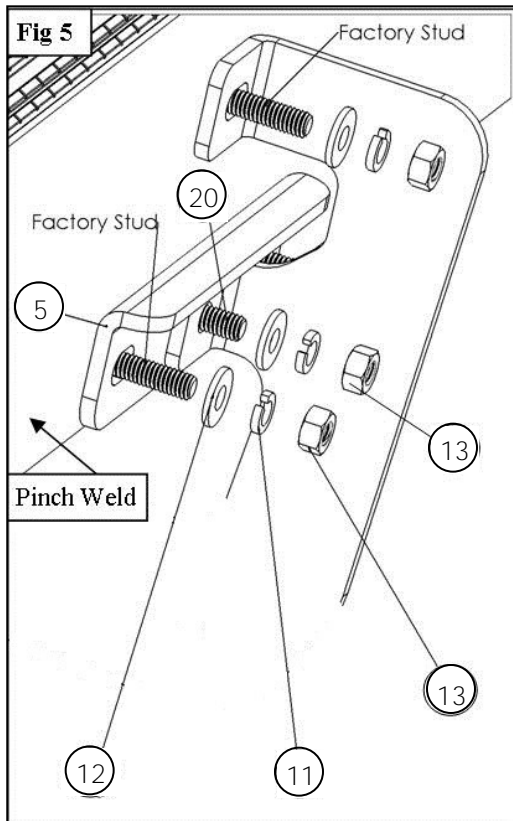

6. At the front passenger mounting location, loosely install Front Mounting Bracket (2) with preassembled Mounting Bracket Base (5). **Note:** Installation is similar to others.
7. Repeat **Steps 4-7** on the driver side of the vehicle.
8. Moving to the rear-most location, install the Top Isolator Bracket (6), Top Isolator Brace (7), and Bottom Isolator Bracket along with the Isolator Kit (9). See **Figures 8 & 9**. You will need to first remove the bolt in the bed as shown in **Figure 7**. **Note:** A breaker-bar or impact gun will help in removal. The bolt is very tight.



Fig. 7

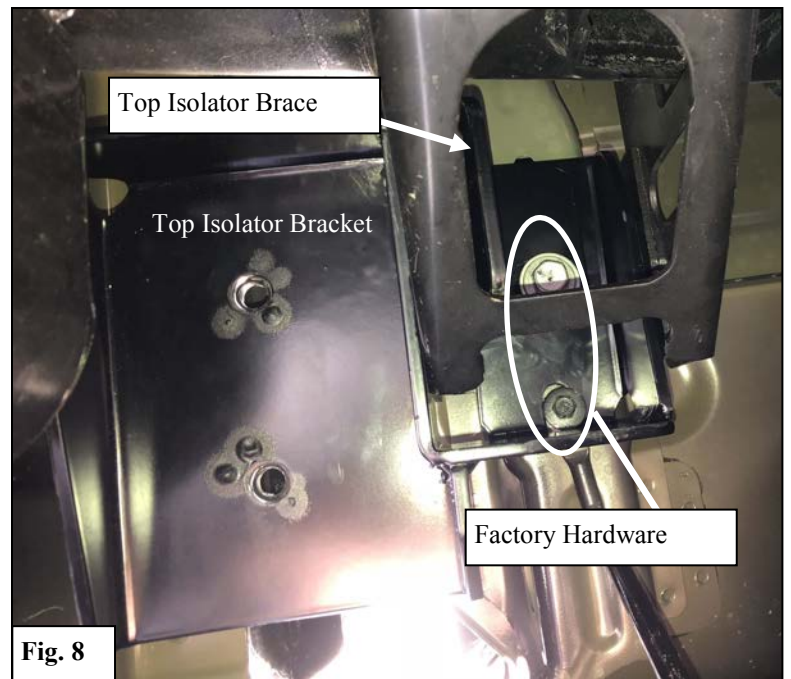
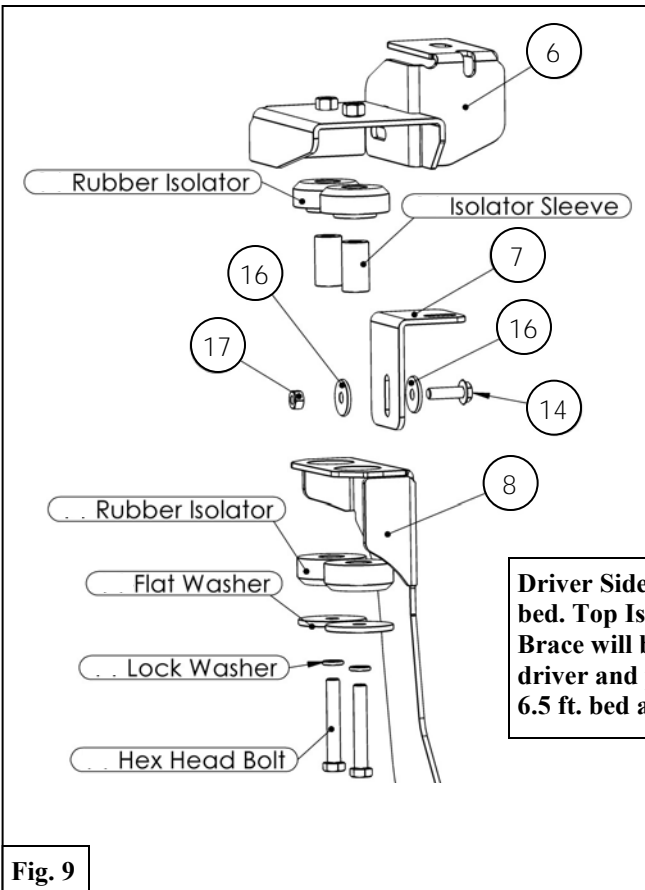

Fig. 8



Driver Side Shown for 5.5 ft. bed. Top Isolator Bracket and Brace will be switched between driver and passenger side for 6.5 ft. bed applications.

Fig. 9

9. Attach the Running Board Assembly (1) to the Mounting Brackets by tilting the board onto the brackets and securing them using the supplied M8 Hardware. See **Figure 10**.

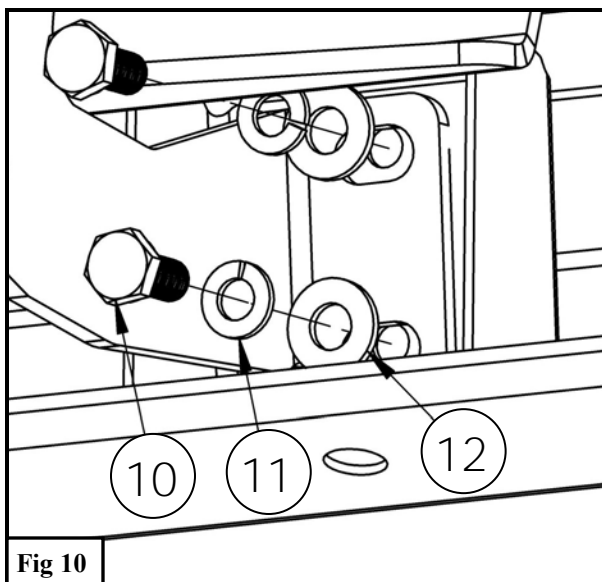
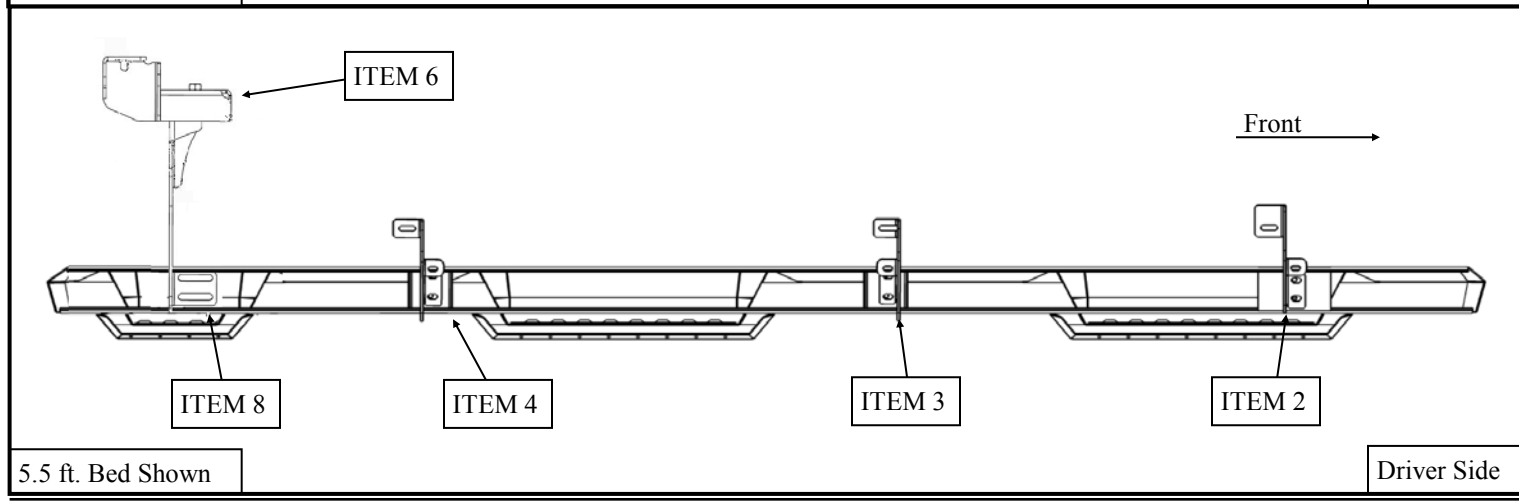
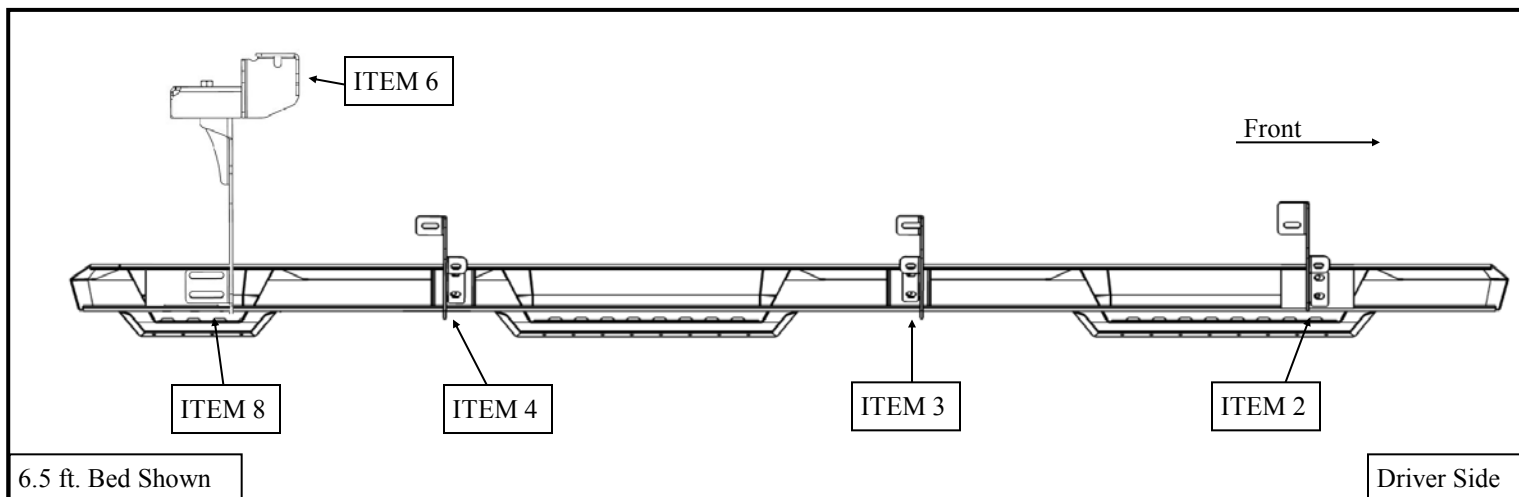

Fig 10



INSTALLATION COMPLETE



5.5 ft. Bed Shown

CARE INSTRUCTIONS

- REGULAR WAXING IS RECOMMENDED. DO NOT USE ANY TYPE OF POLISH OR WAX THAT MAY CONTAIN ABRASIVES
- STAINLESS STEEL PRODUCTS CAN BE CLEANED WITH MILD SOAP AND WATER. STAINLESS STEEL POLISH SHOULD BE USED TO POLISH SMALL SCRATCHES.
- GLOSS BLACK FINISHES SHOULD BE CLEANED WITH MILD SOAP AND WATER

WESTIN



WARNING



Failure to follow these instructions could lead to death, personal injury, and / or property damage.

Failure to follow these instructions could lead to death, personal injury, and / or property damage.

FASTENERS:

All Westin supplied fasteners must be utilized and installed in accordance with the installation instructions and apply torque to the specifications as defined. **DOUBLE CHECK ALL FASTENERS BEFORE INITIAL USE, AND PERIODICALLY IN THE FUTURE TO ENSURE PROPER FUNCTION AND SAFETY.**

DRILLING:

Most Westin products do not require drilling for installation. If drilling is defined as required, use caution when drilling a vehicle. **FAILURE TO REVIEW AN AREA TO BE DRILLED MAY RESULT IN PERSONAL INJURY AND/OR INJURY TO OTHERS AS WELL AS VEHICLE DAMAGE.**

EYE PROTECTION:

ALWAYS WEAR SAFETY GLASSES OR GOGGLES DURING THE INSTALLATION PROCESS TO AVOID PERSONAL INJURY.

MAXIMUM TOWING/CARRYING CAPACITY: (if applicable)

The Westin Receiver Hitches will have a visible tow rating label affixed directly on the product. User should never exceed the vehicle manufacturers maximum tow and weight rating regardless of the capacity of the hitch. **FAILURE TO FOLLOW THESE GUIDELINES WILL VOID THE WESTIN WARRANTY AND MAY RESULT IN PERSONAL INJURY AND/OR INJURY TO OTHERS AS WELL AS VEHICLE DAMAGE.**