



INSTALLATION INSTRUCTIONS

HDX DROP STEP WHEEL-TO-WHEEL NERF STEP BARS

APPLICATION:

2019 Chevy Silverado/GMC Sierra 1500 Crew Cab (6.5 ft. Bed)

2019 Chevy Silverado/GMC Sierra 1500 Double Cab (6.5 ft. Bed)

PART NUMBER:

56-534695, 56-5346952, 56-534715, 56-5347152

CONTENT					
ITEM	QUANTITY	DESCRIPTION	TOOLS NEEDED		
1	2	STEP BAR ASSEMBLY (1 DRIVER, 1 PASSENGER)	13MM SOCKET		
2	4	MOUNTING BRACKET	13MM WRENCH		
3	2	CENTER MOUNTING BRACKET (1 DRIVER, 1 PASSENGER)	10MM SOCKET		
4	1	TOP ISOLATOR BRACKET DRIVER	10MM WRENCH		
5	2	BOTTOM ISOLATOR BRACKET (1 DRIVER, 1 PASSENGER)	15MM SOCKET		
6	2	REINFORCEMENT LINK (1 DRIVER, 1 PASSENGER)	1/2" EXTENSION		
7	4	ISOLATOR KIT	RATCHET		
8	12	M8 U-NUT	TORQUE WRENCH		
9	18	LONGER M8 HEX HEAD CAP SCREW	IMPACT GUN		
10	12	SHORTER M8 HEX HEAD CAP SCREW	BREAKER BAR		
11	32	M8 SPLIT LOCK WASHER			
12	32	M8 FLAT WASHER			
13	4	M12 SPLIT LOCK WASHER			
14	4	LONG M12 HEX HEAD CAP SCREW			
15	2	SHORT M12 HEX HEAD CAP SCREW			
16	6	M12 FLAT WASHER			
17	2	M12 SERRATED FLANGE NUT			
18	4	M12 HEX NUT			
19	1	TOP ISOLATOR BRACKET PASSENGER			
20	2	M8 FISHWIRE			
21	2	M8 HEX NUT			
22	2	M8 BOLT PLATE			
ITEM 1	DRIVER SIDE ITEMS SHOWN; PASSENGER SIDE OPPOSITE		ITEM 7		
ITEM 2	ITEM 3	ITEM 4	ITEM 19	ITEM 5	ITEM 6



PROCEDURE

1. Remove contents from box, verify if all parts listed are present and free from damage.
Carefully read and understand all instructions before attempting installation.

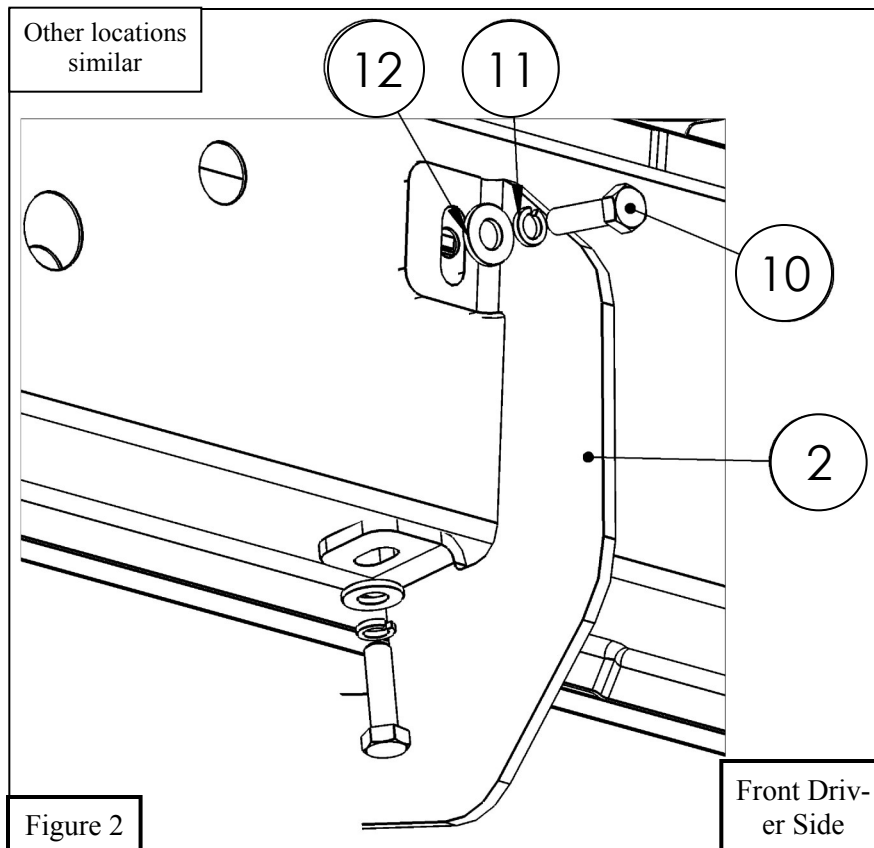
Failure to identify damage before installation could lead to a rejection of any claim.

2. Starting on the driver side, remove the rubber plugs located on the rocker panel at each mounting location. See **Figure 1**.
3. **For models with threaded holes:** At each bracket mounting location on the rocker panel there should be a welded factory nut.

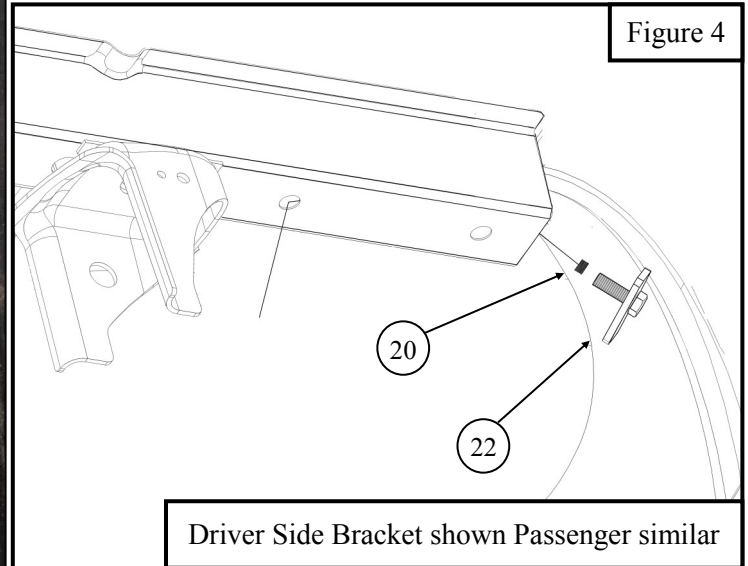
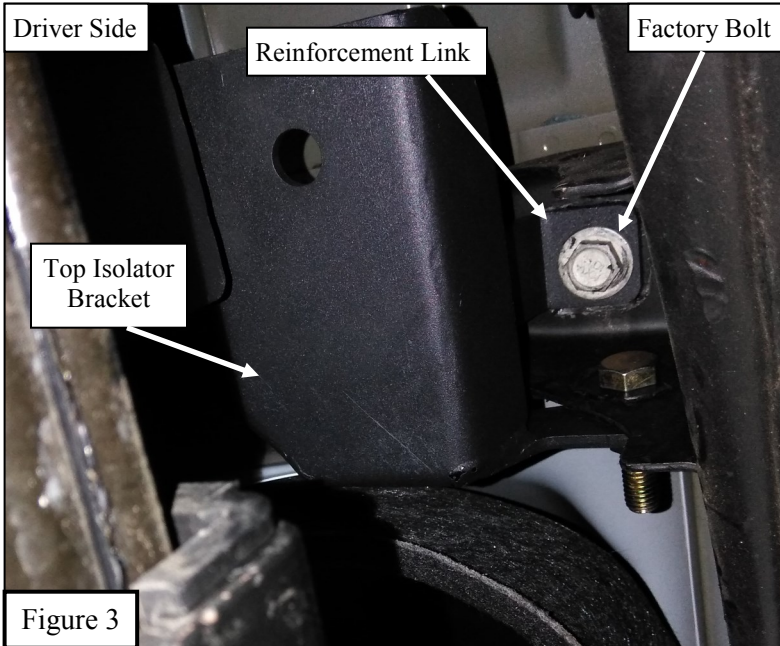


Figure 1

4. Locate (1) Mounting Bracket (Item 2) and loosely secure it to the rocker panel using the provided hardware: (2) M8 hex head bolt, (2) M8 flat washer, and (2) M8 lock washer. See **Figure 2**.
5. Repeat **Step 4** for all remaining bracket mounting locations. See **Figure 9 on pg. 4**



6. Use supplied M8 Bolt Plate and M8 Fish Wire to Fish the Bolt plate through the bed channel. See **Figure 4**
7. Remove the OEM Bed bolts to be used on the top Isolator Bracket (4). Then install the Top Isolator Bracket (4) using the OEM bolts, M8 Split Lock Washer, M8 Flat Washer, M8 Nut, and supplied M12 Bolt, M12 Lock Washer, and M12 Flat Washer. See **Figure 4 & 5**.



8. Attach the Bottom Isolator Bracket (5) to the Top Isolator Bracket (4) using the Isolator Kit (7) and hardware. See **Figure 4**.

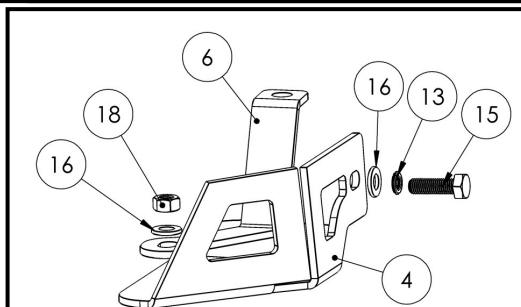
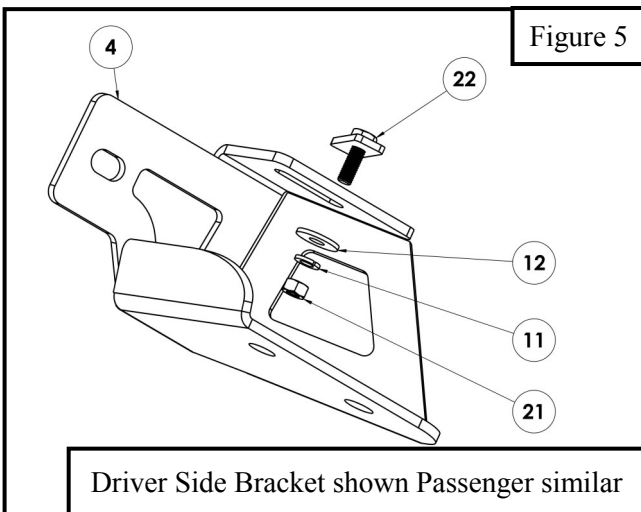
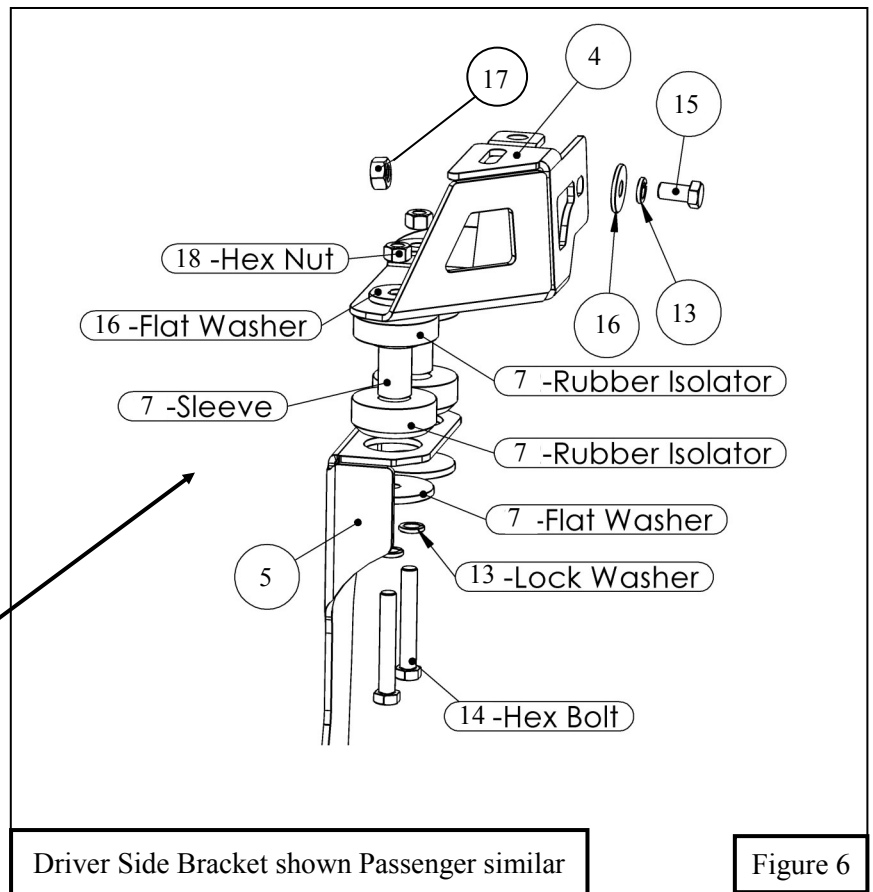
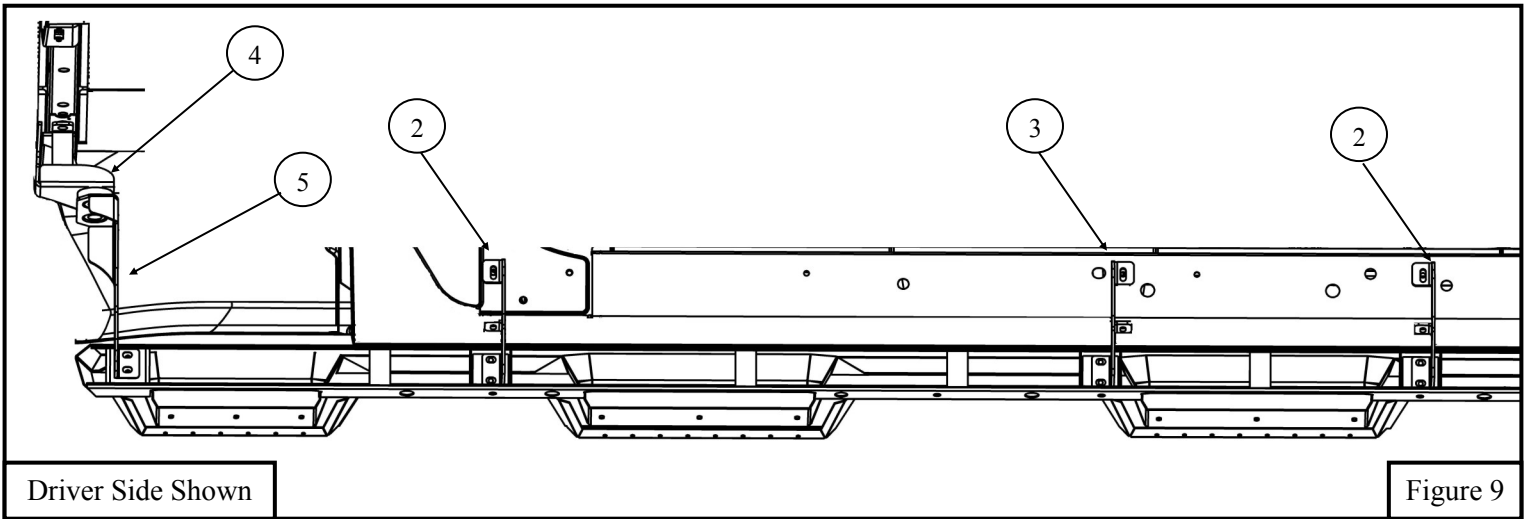
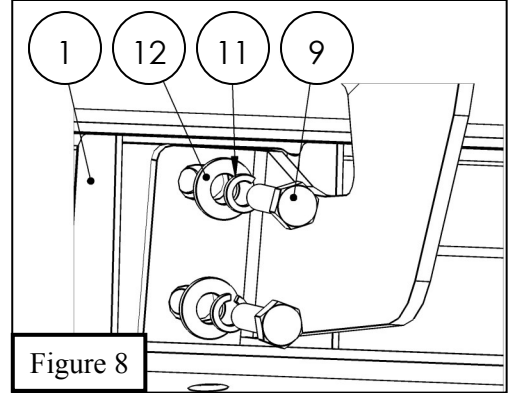
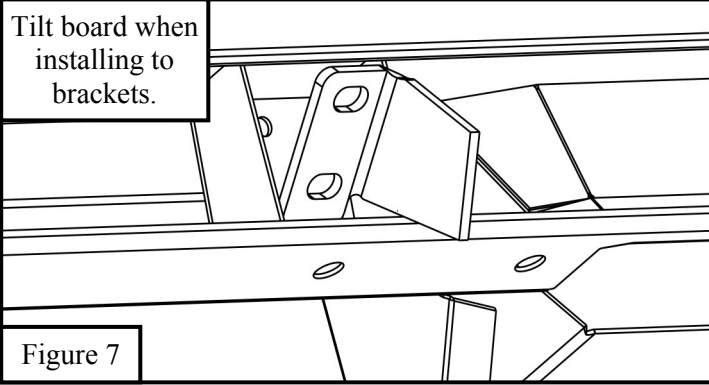


Image modified for clarity



8. For Step Board installation, tilt board at an angle to insert brackets into mounting locations. With the previously installed mounting brackets use the supplied M8 hardware with the short M8 hex head bolt, then loosely install. See **Figures 7 & 8**.
9. Align and adjust the step bars and brackets as needed, then fully tighten all hardware: M8 to 15-18 ft-lbs, M12 to 55 ft-lbs..



INSTALLATION COMPLETE



Care Instructions

- REGULAR WAXING IS RECOMMENDED. DO NOT USE ANY TYPE OF POLISH OR WAX THAT MAY CONTAIN ABRASIVES.
- STAINLESS STEEL PRODUCTS CAN BE CLEANED WITH MILD SOAP AND WATER. STAINLESS STEEL POLISH SHOULD BE USED TO POLISH SMALL SCRATCHES.
- GLOSS BLACK FINISHES SHOULD BE CLEANED WITH MILD SOAP AND WATER.

WESTIN