



INSTALLATION INSTRUCTIONS

HDX DROP STEP WHEEL-TO-WHEEL NERF STEP BARS

APPLICATION:





2019 Chevy Silverado/GMC Sierra 1500 Crew Cab (5.5 ft. Bed)

PART NUMBER:

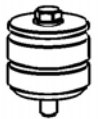
56-534685, 56-534682

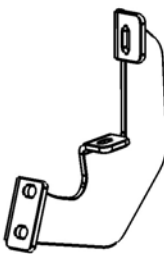
CONTENT			
ITEM	QUANTITY	DESCRIPTION	TOOLS NEEDED
1	2	STEP BAR ASSEMBLY (1 DRIVER, 1 PASSENGER)	13MM SOCKET
2	4	MOUNTING BRACKET	13MM WRENCH
3	2	CENTER MOUNTING BRACKET (1 DRIVER, 1 PASSENGER)	10MM SOCKET
4	2	TOP ISOLATOR BRACKET (1 DRIVER, 1 PASSENGER)	10MM WRENCH
5	2	BOTTOM ISOLATOR BRACKET (1 DRIVER, 1 PASSENGER)	15MM SOCKET
6	2	REINFORCEMENT LINK (1 DRIVER, 1 PASSENGER)	1/2" EXTENSION
7	2	ISOLATOR KIT	RATCHET
8	12	M8 U-NUT	TORQUE WRENCH
9	12	LONGER M8 HEX HEAD CAP SCREW	IMPACT GUN
10	16	SHORTER M8 HEX HEAD CAP SCREW	BREAKER BAR
11	28	M8 SPLIT LOCK WASHER	
12	28	M8 FLAT WASHER	
13	4	M12 SPLIT LOCK WASHER	
14	2	LONG M12 HEX HEAD CAP SCREW	
15	2	SHORT M12 HEX HEAD CAP SCREW	
16	4	M12 FLAT WASHER	
17	2	M12 SERRATED FLANGE NUT	
18	2	M12 HEX NUT	

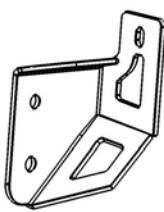

ITEM 1	DRIVER SIDE ITEMS SHOWN; PASSENGER SIDE OPPOSITE				ITEM 7
				Front	
ITEM 2	ITEM 3	ITEM 4	ITEM 5	ITEM 6	



PROCEDURE

1. Remove contents from box, verify if all parts listed are present and free from damage.

Carefully read and understand all instructions before attempting installation.

Failure to identify damage before installation could lead to a rejection of any claim.

2. Starting on the driver side, remove the rubber plugs located on the rocker panel at each mounting location. See **Figure 1**.
3. **For models with threaded holes:** At each bracket mounting location on the rocker panel there should be a welded factory nut.



Figure 1

4. Locate (1) Mounting Bracket (Item 2) and loosely secure it to the rocker panel using the provided hardware: (2) M8 hex head bolt, (2) M8 flat washer, and (2) M8 lock washer. See **Figure 2**.
5. Repeat **Step 4** for all remaining bracket mounting locations.

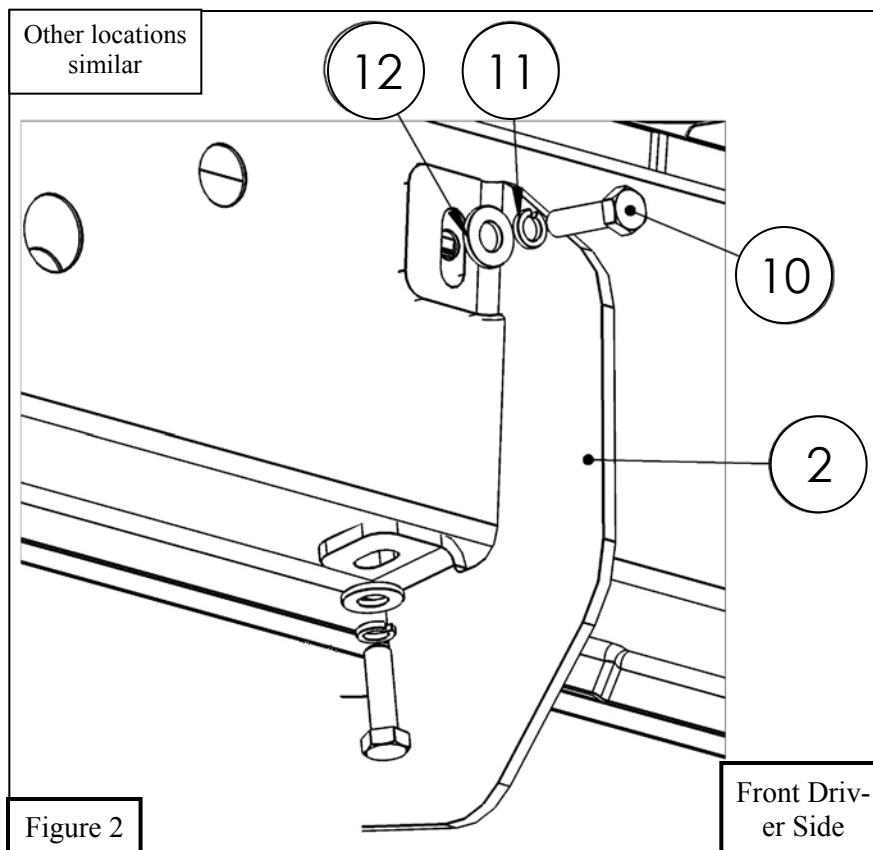
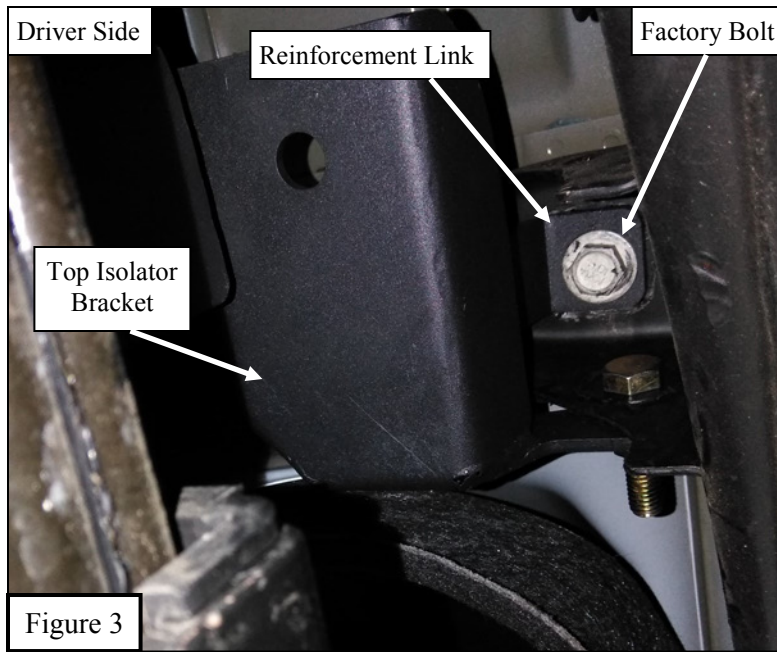
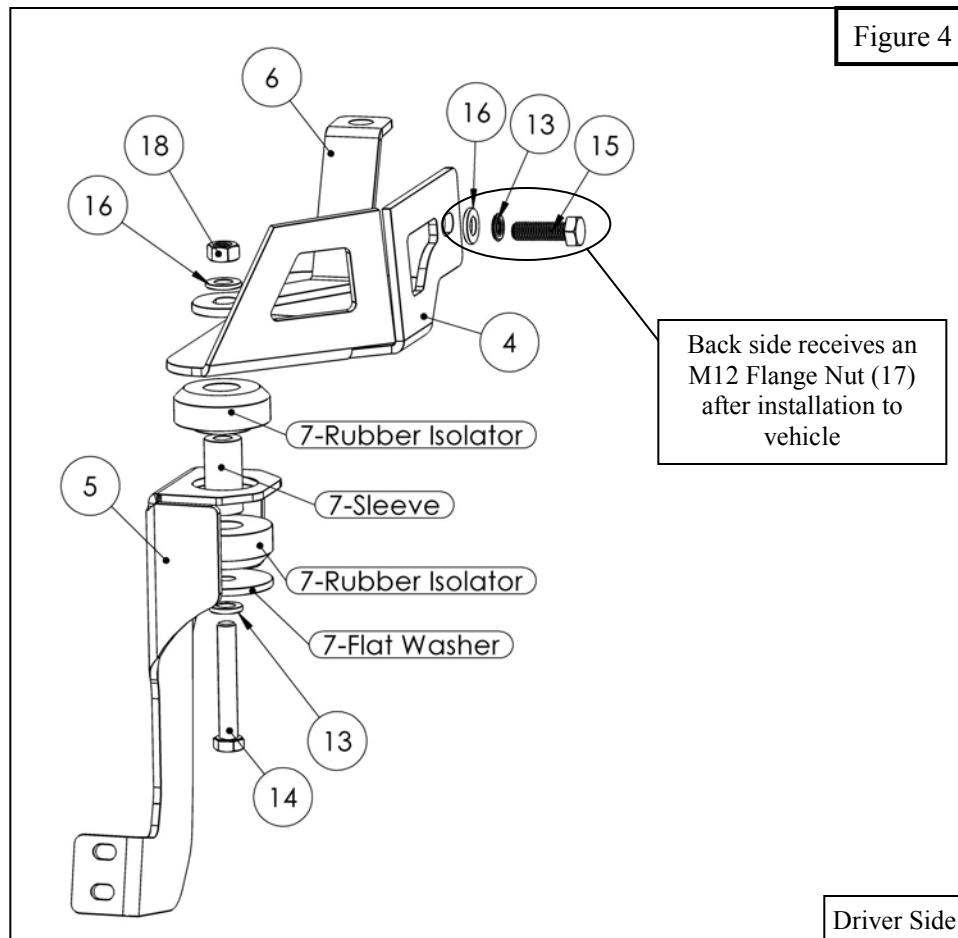

Figure 2

6. Remove the OEM Bed bolts to be used on the top Isolator Bracket (4). Then install the Top Isolator Bracket (4) using the OEM bolts, supplied U-Nut (8), and supplied M12 Bolt, M12 Lock Washer, and M12 Flat Washer. See **Figure 3**.



7. Attach the Bottom Isolator Bracket (5) to the Top Isolator Bracket (4) using the Isolator Kit (7) and hardware. See **Figure 4**.



8. For Step Board installation, tilt board at an angle to insert brackets into mounting locations. With the previously installed mounting brackets use the supplied M8 hardware with the short M8 hex head bolt, then loosely install. See **Figures 5 & 6**.
9. Align and adjust the step bars and brackets as needed, then fully tighten all hardware: M8 to 15-18 ft-lbs.

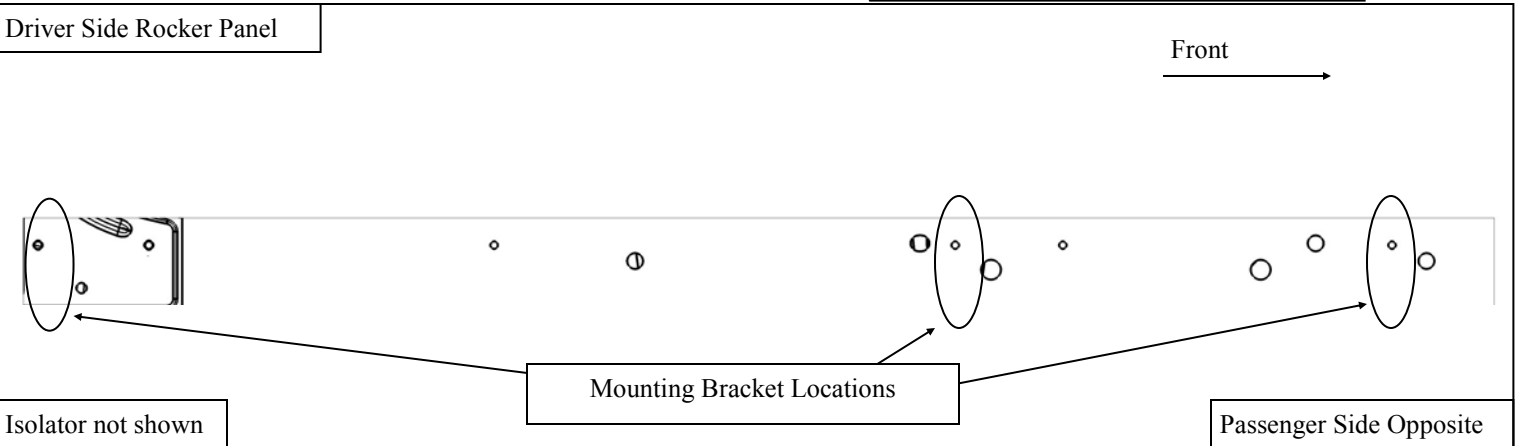
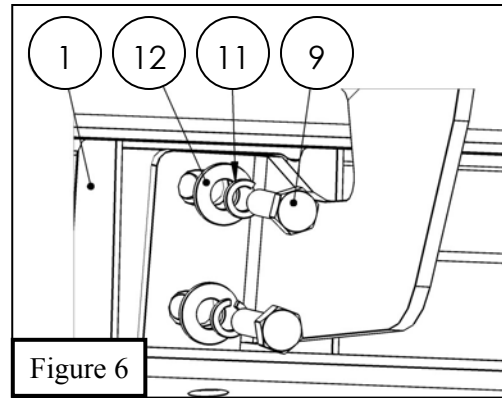
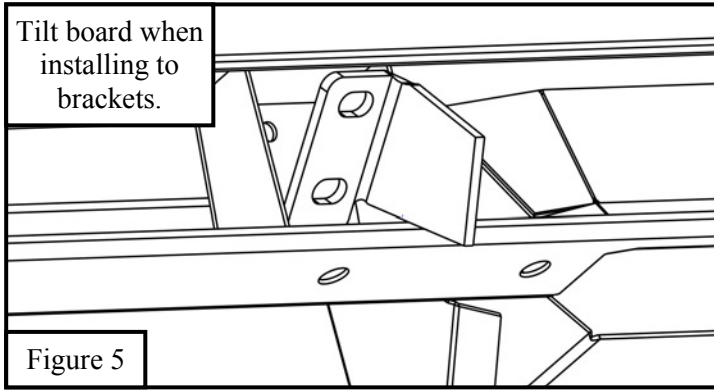



WARNING



Failure to follow these instructions could lead to death, personal injury, and / or property damage.

Failure to follow these instructions could lead to death, personal injury, and / or property damage.

FASTENERS:

All Westin supplied fasteners must be utilized and installed in accordance with the installation instructions and apply torque to the specifications as defined. **DOUBLE CHECK ALL FASTENERS BEFORE INITIAL USE, AND PERIODICALLY IN THE FUTURE TO ENSURE PROPER FUNCTION AND SAFETY.**

DRILLING:

Most Westin products do not require drilling for installation. If drilling is defined as required, use caution when drilling a vehicle. **FAILURE TO REVIEW AN AREA TO BE DRILLED MAY RESULT IN PERSONAL INJURY AND/OR INJURY TO OTHERS AS WELL AS VEHICLE DAMAGE.**

EYE PROTECTION:

ALWAYS WEAR SAFETY GLASSES OR GOGGLES DURING THE INSTALLATION PROCESS TO AVOID PERSONAL INJURY.

MAXIMUM TOWING/CARRYING CAPACITY: (if applicable)

The Westin Receiver Hitches will have a visible tow rating label affixed directly on the product. User should never exceed the vehicle manufacturers maximum tow and weight rating regardless of the capacity of the hitch. **FAILURE TO FOLLOW THESE GUIDELINES WILL VOID THE WESTIN WARRANTY AND MAY RESULT IN PERSONAL INJURY AND/OR INJURY TO OTHERS AS WELL AS VEHICLE DAMAGE.**



[View other grille guards and bull bars made by Westin on our website.](#)