

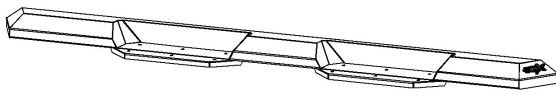

INSTALLATION INSTRUCTIONS

HDX XTREME RUNNING BOARDS

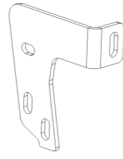
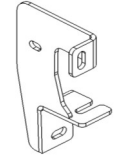

APPLICATION:
2020 Jeep Gladiator
PART NUMBER:
56-24165

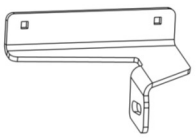
CONTENT			
ITEM	QUANTITY	DESCRIPTION	TOOLS NEEDED
1	1	HDX XTREME RUNNING BOARD DRIVER SIDE	RATCHET
2	1	HDX XTREME RUNNING BOARD PASSENGER SIDE	TORQUE WRENCH
3	1	FRONT MOUNTING BRACKET DRIVER SIDE	10MM SOCKET
4	1	FRONT MOUNTING BRACKET PASSENGER SIDE	13MM SOCKET
5	1	CENTER MOUNTING BRACKET DRIVER SIDE	13MM WRENCH
6	1	CENTER MOUNTING BRACKET PASSENGER SIDE	SOCKET EXT.
7	1	REAR MOUNTING BRACKET DRIVER SIDE	ALLEN WRENCH
8	1	REAR MOUNTING BRACKET PASSENGER SIDE	
9	3	SUPPORT BRACKETS DRIVER SIDE	
10	3	SUPPORT BRACKETS PASSENGER SIDE	
11	6	M8 U-NUT (YELLOW ZINC)	
12	4	M8 HEX HEAD CAP SCREW (SHORT, YELLOW ZINC)	
13	20	M8 HEX HEAD CAP SCREW (LONG, YELLOW ZINC)	
14	24	M8 SPLIT LOCK WASHER (YELLOW ZINC)	
15	6	M8 HEX NUT (YELLOW ZINC)	
16	30	M8 FLAT WASHER (YELLOW ZINC)	
17	12	M6 HEX NUT (YELLOW ZINC)	
18	12	M6 FLAT WASHER (YELLOW ZINC)	
19	12	M6 SPLIT LOCK WASHER (YELLOW ZINC)	
20	12	M6 CARRIAGE BOLT (BLACK ZINC)	
ANTI-SEIZE LUBRICANT MUST BE USED ON ALL STAINLESS STEEL FASTENERS TO PREVENT THREAD DAMAGE AND GALLING			
<div style="display: flex; justify-content: space-around; align-items: center;"> <div style="text-align: center;"> <p>ITEM 1</p>  </div> <div style="text-align: center;"> <p>ITEM 3</p>  </div> <div style="text-align: center;"> <p>ITEM 5</p>  </div> <div style="text-align: center;"> <p>ITEM 7</p>  </div> <div style="text-align: center;"> <p>ITEM 9</p>  </div> </div>			
NOTE: DRIVER SIDE ITEMS SHOWN. PASSENGER SIDE ITEMS ARE OPPOSITES			



PROCEDURE

1. Remove contents from box, verify if all parts listed are present and free from damage. Carefully read and understand all instructions before attempting installation.
Failure to identify damage before installation could lead to a rejection of any claim.
2. Starting at the front mount location, locate (1) Driver Support Bracket (Item 9). Loosely secure brackets, using the supplied M6 hardware as shown in **Figure 1 and Figure 2**

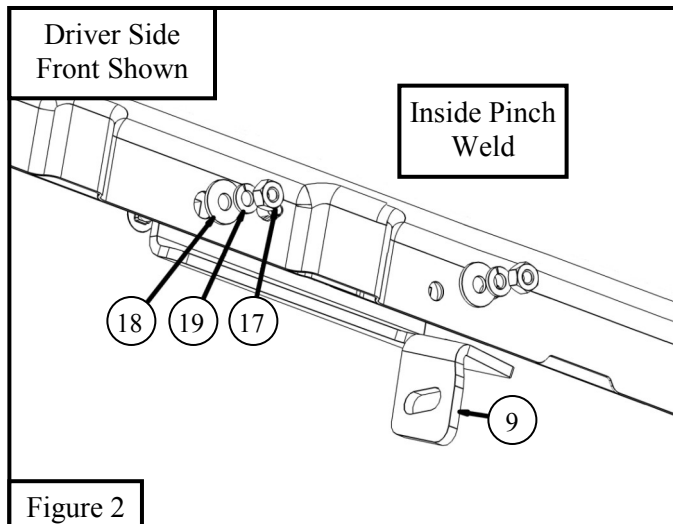
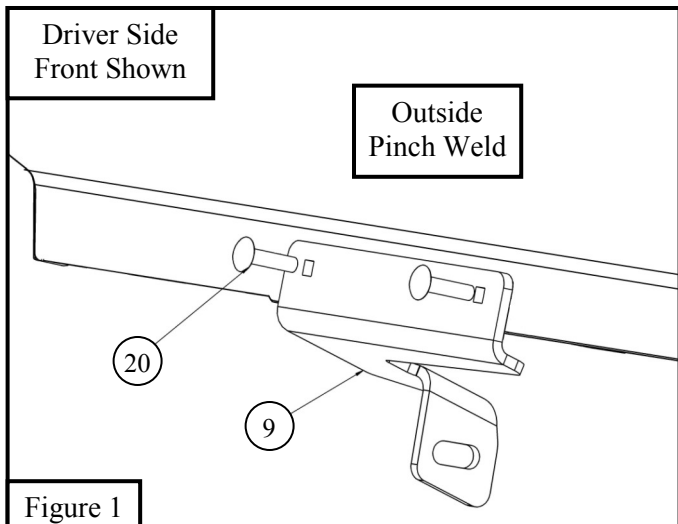

3. Starting on the drivers side loosely install Rear and Center brackets **FIRST**. Installation is similar to front mount bracket. Please refer to **Figure 3 and Figures 6 & 7** for bracket orientation and location.
4. Locate (1) HDX Running Board and loosely secure it onto the previously installed rear and center brackets using the provided M8 hardware. Partially insert M8 hardware into board and slide the slotted bracket onto the bolt. See **Figure 4**
5. Torque the bolts as far as they can go while still having adjustment.
6. Then locate (1) Front Driver Side Mounting Bracket (Item 3). Loosely secure bracket to vehicle and previously installed support bracket using the supplied M8 hardware as shown in **Figure 3**. [**Note:** If a threaded hole is not present use the supplied M8 U-Nut Clip (Item 11)].

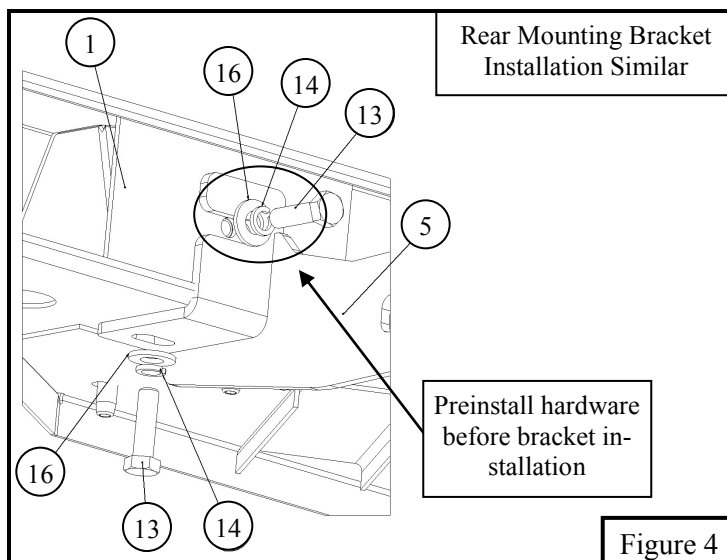
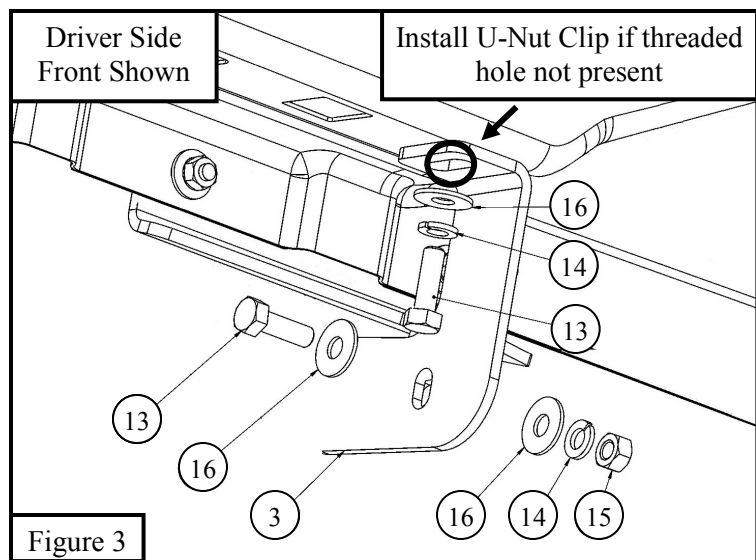

7. Loosely install Front Mounting Bracket with supplied M8 hardware. See **Figure 5**
8. Repeat steps 2 - 7 for passenger side.
9. Align running boards and brackets to desired positioning then torque and tighten all: M6 Hardware to 7 ft-lbs, M8 hardware to 16 ft-lbs.

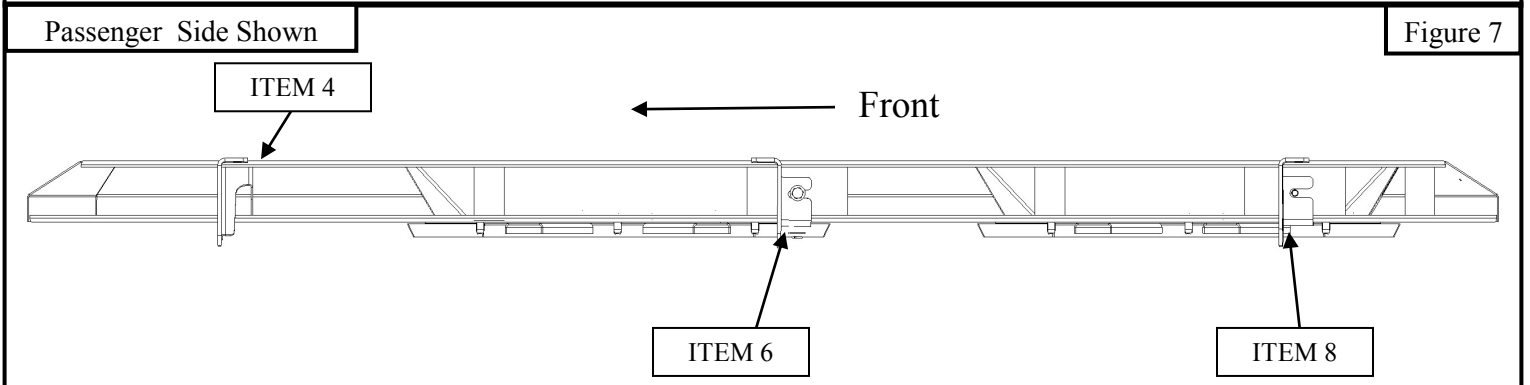
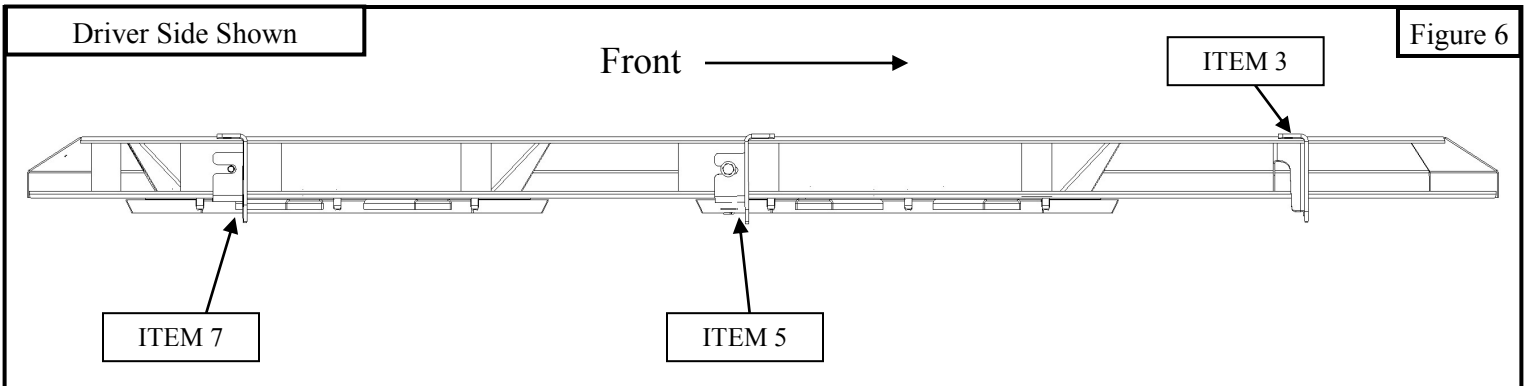
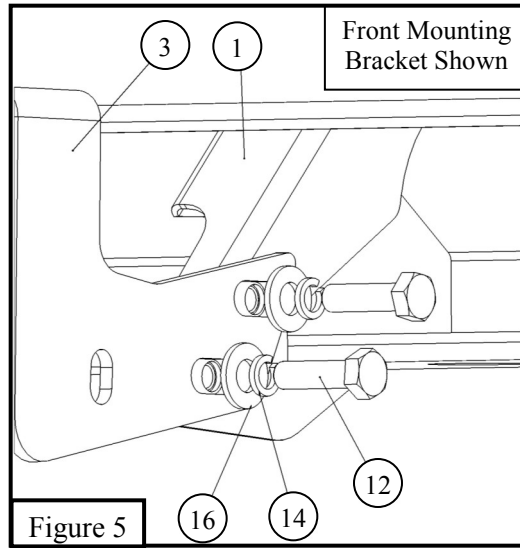

INSTALLATION COMPLETE



CARE INSTRUCTIONS

- REGULAR WAXING IS RECOMMENDED. DO NOT USE ANY TYPE OF POLISH OR WAX THAT MAY CONTAIN ABRASIVES.
- STAINLESS STEEL PRODUCTS CAN BE CLEANED WITH MILD SOAP AND WATER. STAINLESS STEEL POLISH SHOULD BE USED TO POLISH SMALL SCRATCHES.
- GLOSS BLACK FINISHES SHOULD BE CLEANED WITH MILD SOAP AND WATER.

WESTiN