

# INSTALLATION INSTRUCTIONS



Xtreme Board

**APPLICATION:**

2019 Chevrolet Silverado / GMC Sierra 1500  
Crew Cab / Double Cab

**PART NUMBER:**

56-24135, 56-24125

ITEM	QUANTITY	DESCRIPTION	TOOLS NEEDED
1	2	STEP BAR ASSEMBLY	RATCHET 1/4" & 3/8"
2,3	2	CENTER MOUNT BRACKET, DRIVER (2) AND PASSENGER (3)	TORQUE WRENCH
4	4	MOUNTING BRACKET	10MM SOCKET
5	24	M8 HEX HEAD BOLT LONG (YELLOW ZINC)	SOCKET EXT.
9	12	M8 U-NUT CLIP (YELLOW ZINC)	13MM SOCKET
7	24	M8 FLAT WASHER (YELLOW ZINC)	13MM WRENCH
8	24	M8 LOCK WASHER (YELLOW ZINC)	

**ANTI-SEIZE LUBRICANT MUST BE USED ON ALL STAINLESS STEEL FASTENERS TO PREVENT THREAD DAMAGE AND GALLING**

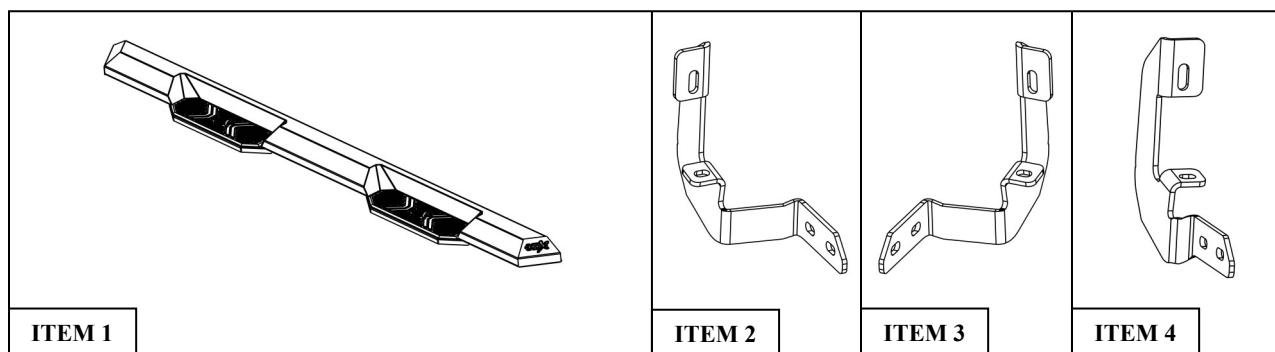

**PROCEDURE**

- Remove contents from box, verify if all parts listed are present and free from damage. Carefully read and understand all instructions before attempting installation.  
**Failure to identify damage before installation could lead to a rejection of any claim.**
- Locate the mount locations on the rocker panel of the vehicle. Remove the rubber plugs covering the threaded holes.
- Locate (1) Mounting Bracket (Item 4) and loosely secure it to the rocker panel using the provided hardware: (2) M8 hex head bolt (2) M8 flat washer, and (2) M8 lock washer. See **Figure 1**. (**Note:** If threaded holes are not on trucks rocker panel, remove the rubber plugs located on the rocker panel at each mounting location and insert nut clips.) See **Figure 3**.
- Repeat **Step 4** for every other bracket mounting location, see **Page 3** for bracket orientation and location.



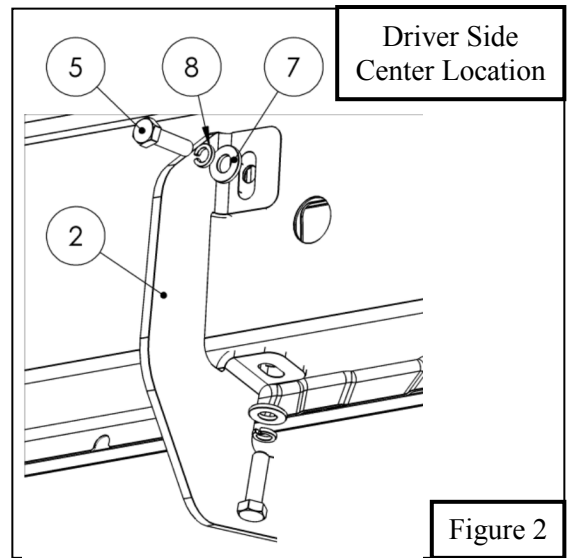
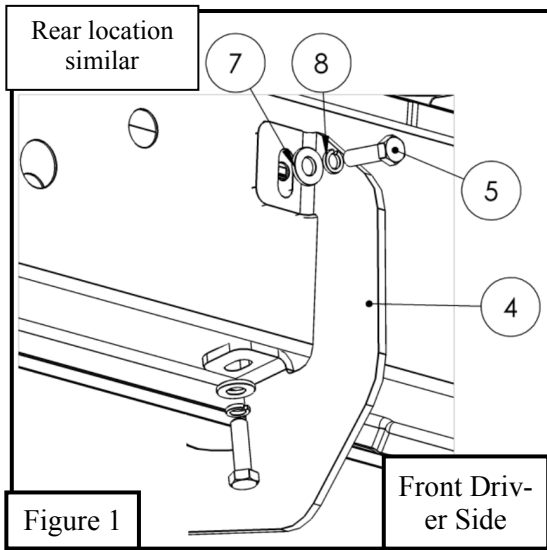

5. Locate (1) Center Mount Bracket (Item 2-3). Loosely secure Center Mount Bracket to the rocker panel using (2) M8 hex head bolt (2) M8 flat washer, and (2) M8 lock washer. See **Figure 2**. Refer to **Page 3** bracket orientation figures.

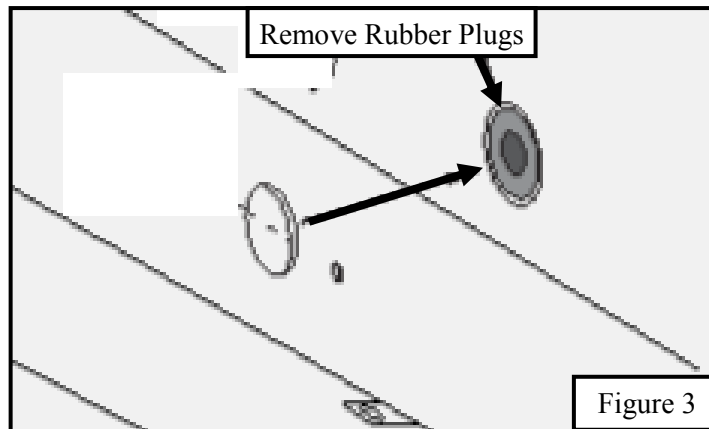

6. For Step Board installation, mount the board to previously installed brackets with the supplied M8 hardware. See **Figure 4**
7. Align and adjust the step bars and brackets as needed, then fully tighten all hardware: M8 to 15-18 ft-lbs.

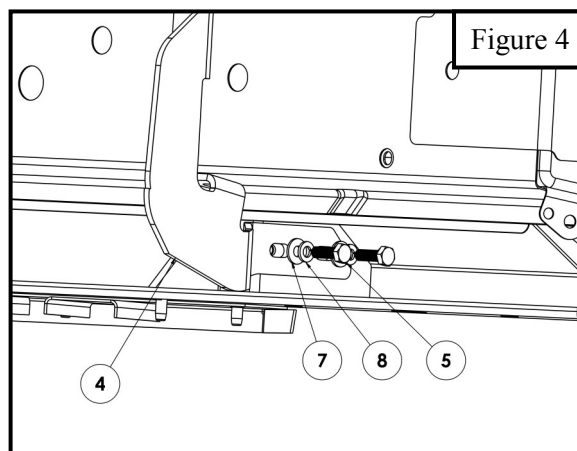

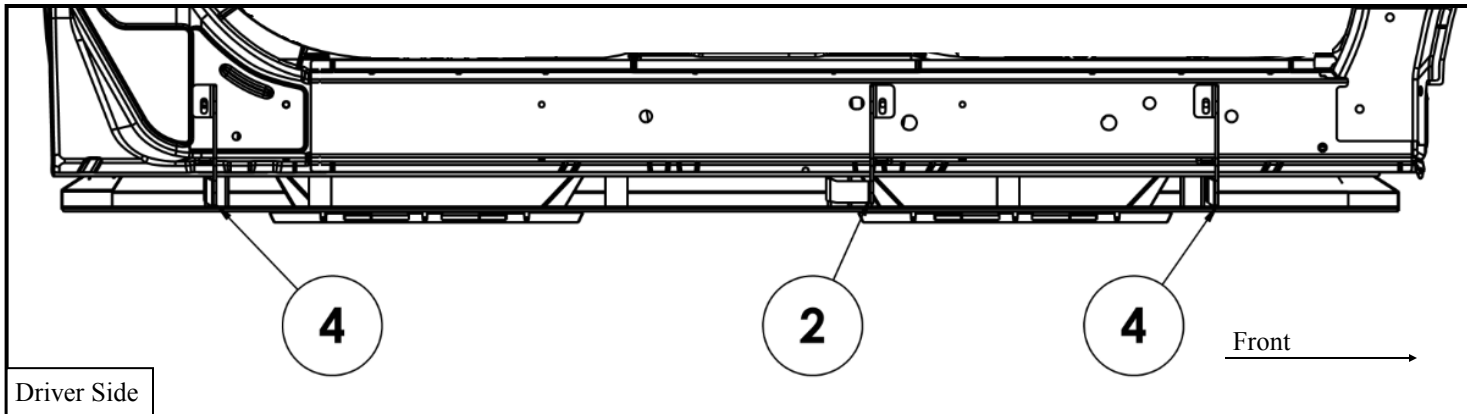

#### Care Instructions

- REGULAR WAXING IS RECOMMENDED. DO NOT USE ANY TYPE OF POLISH OR WAX THAT MAY CONTAIN ABRASIVES.
- STAINLESS STEEL PRODUCTS CAN BE CLEANED WITH MILD SOAP AND WATER. STAINLESS STEEL POLISH SHOULD BE USED TO POLISH SMALL SCRATCHES.
- GLOSS BLACK FINISHES SHOULD BE CLEANED WITH MILD SOAP AND WATER.

**WESTIN**