

INSTALLATION INSTRUCTIONS



**GASOLINE TRUCKS ONLY
HDX XTREME BOARD**

APPLICATION:

**2007-2017 Chevrolet Silverado / GMC Sierra 1500/2500/3500
Extended, Crew, Double Cab (Excludes Classic)**

PART NUMBER: 56-23715, 56-23725

ITEM	QUANTITY	DESCRIPTION	TOOLS NEEDED
1	2	STEP BAR ASSEMBLY	RATCHET 1/4" & 3/8"
2	1	MOUNT BRACKET A	TORQUE WRENCH
3	1	MOUNT BRACKET B	13MM SOCKET
4	1	DRIVER SIDE CENTER MOUNT BRACKET	13MM WRENCH
5	1	MOUNT BRACKET C	SOCKET EXT.
6	1	MOUNT BRACKET D	FLASH LIGHT
7	12	M8 EXTRUDED U-NUT	SWIVLE RATCHET
8	24	M8 HEX HEAD CAP SCREW	
9	24	M8 SPLIT LOCK WASHER	
10	24	M8 FLAT WASHER	
11	1	PASSENGER SIDE CENTER MOUNT BRACKET	
12*	1	MOUNT BRACKET E	

ANTI-SEIZE LUBRICANT MUST BE USED ON ALL STAINLESS STEEL FASTENERS TO PREVENT THREAD DAMAGE AND GALLING

ITEM WITH (*) - IS ONLY USED FOR 1500 CREW APPLICATIONS

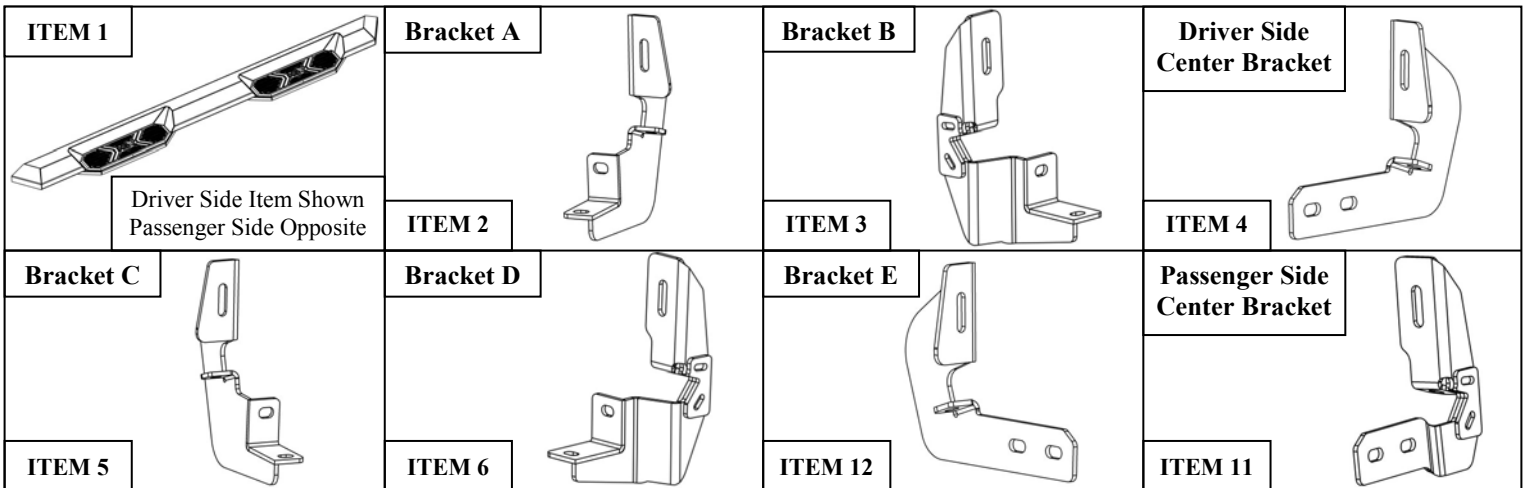

PROCEDURE

1. Remove contents from box, verify if all parts listed are present and free from damage.
Carefully read and understand all instructions before attempting installation.
Failure to identify damage before installation could lead to a rejection of any claim.



2. Starting on the driver side, remove the rubber plugs located on the rocker panel at each mounting location. See **Figure 1**.
3. **For models with welded nuts:** At each bracket mounting location on the pinch weld there should either be a welded factory nut or a hole. If there is a factory welded nut present, then the M8 extruded u-nut (Item 7) will not be used at that location. See **Figure 2** for the factory welded nut.

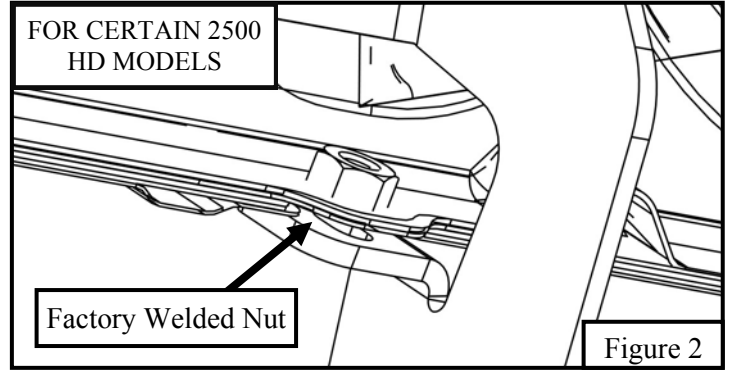
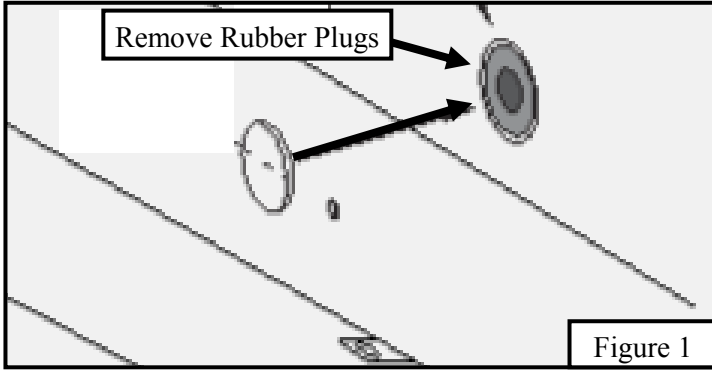

4. Insert (1) M8 extruded u-nut (Item 7) into the hole where the rubber plug was removed. Clip (1) M8 extruded u-nut onto pinch weld if no factory welded nut is present. Locate (1) Mounting Bracket and loosely secure it to the rocker panel using the provided hardware: (2) M8 hex head cap screw, (2) M8 flat washer, and (2) M8 lock washer. See **Figures 3 - 6**. Repeat **Step 4** for every other bracket mounting location, see **Page 3** for bracket orientation and location.
5. Loosely secure the Xtreme board to the previously installed brackets using the provided M8 hardware. See **Figure 7**.
6. Align the Xtreme board and brackets to desired positioning then torque and tighten all: M8 hardware to 15-18 ft-lbs.

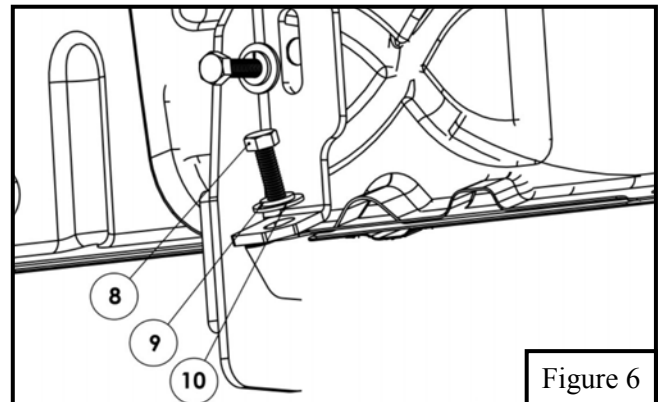
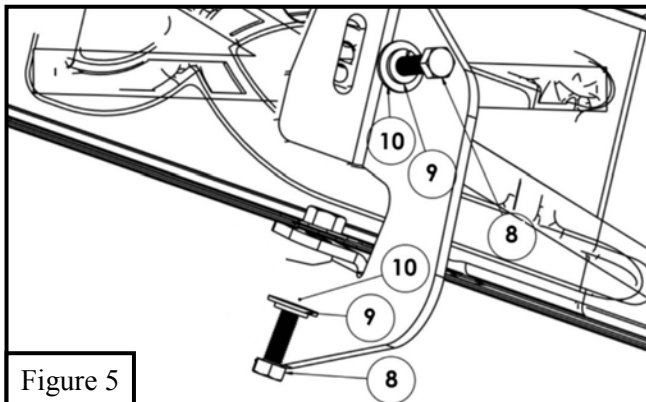
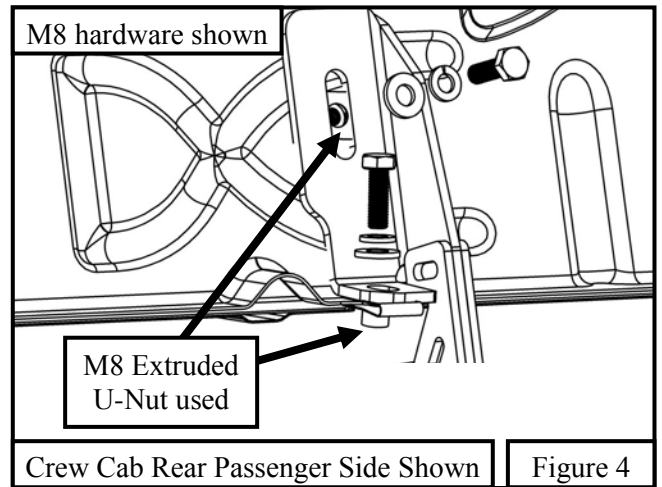
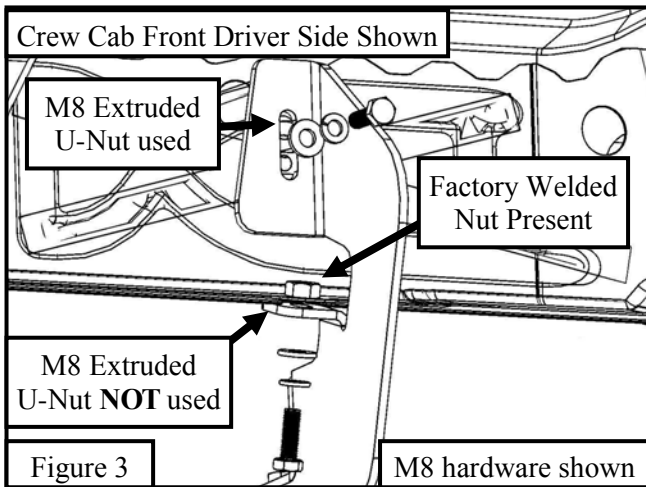

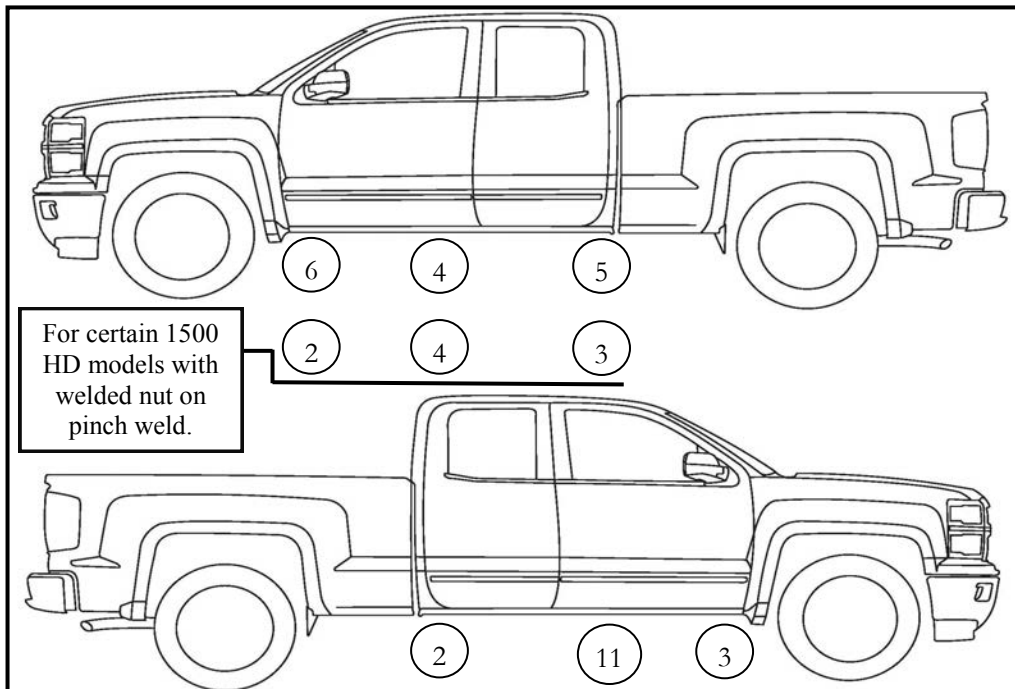
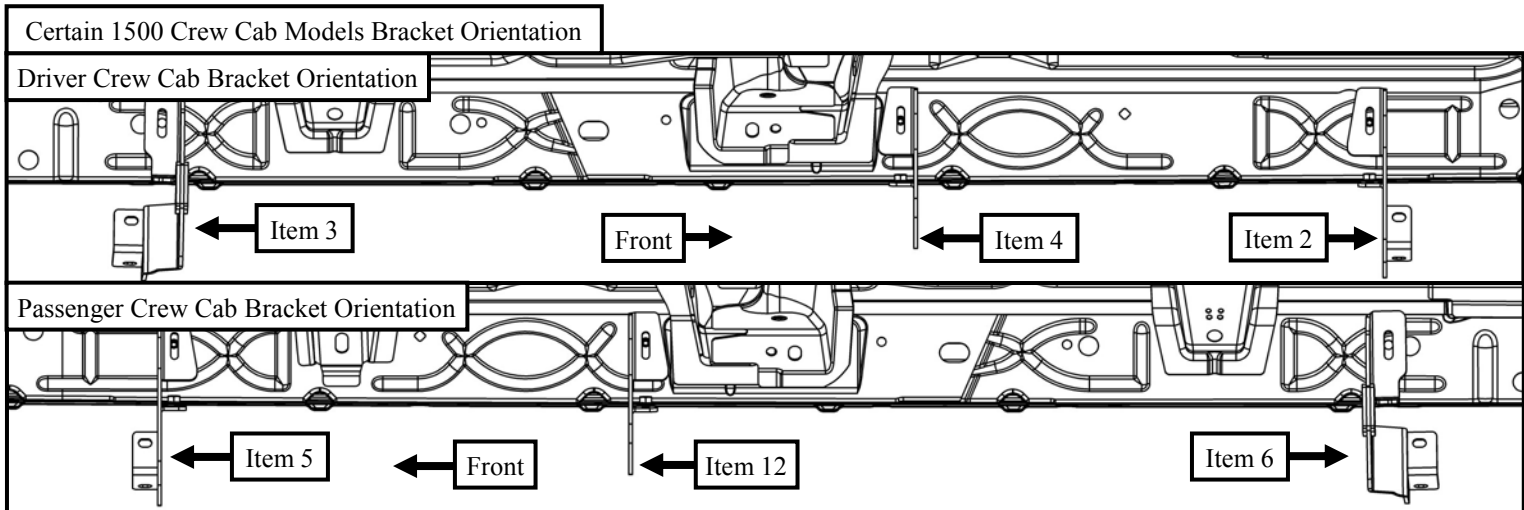
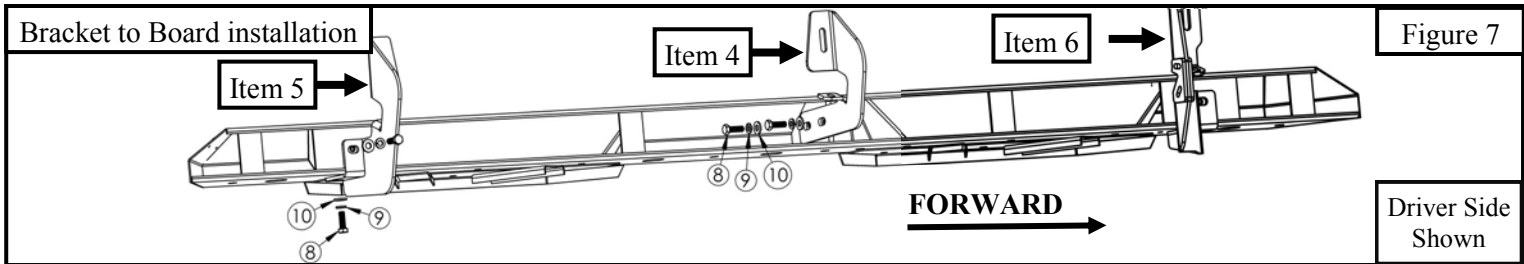

INSTALLATION COMPLETE



Care Instructions

- REGULAR WAXING IS RECOMMENDED. DO NOT USE ANY TYPE OF POLISH OR WAX THAT MAY CONTAIN ABRASIVES.
- STAINLESS STEEL PRODUCTS CAN BE CLEANED WITH MILD SOAP AND WATER. STAINLESS STEEL POLISH SHOULD BE USED TO POLISH SMALL SCRATCHES.
- GLOSS BLACK FINISHES SHOULD BE CLEANED WITH MILD SOAP AND WATER.

WESTiN