

# INSTALLATION INSTRUCTIONS

## HDX DROP STEPS



**APPLICATION:**  
2018 Jeep Wrangler JL Unlimited  
**PART NUMBER:**  
56-14065, 56-140652

CONTENT			
ITEM	QUANTITY	DESCRIPTION	TOOLS NEEDED
1	2	STEP BAR ASSEMBLY (1 DRIVER, 1 PASSENGER)	RATCHET
2,3	2	FRONT MOUNTING BRACKET (1 DRIVER, 1 PASSENGER)	TORQUE WRENCH
4,5	2	CENTER MOUNTING BRACKET (1 DRIVER, 1 PASSENGER)	10MM SOCKET
6,7	2	REAR MOUNTING BRACKET (1 DRIVER, 1 PASSENGER)	13MM SOCKET
8,9	6	SUPPORT BRACKET (3 DRIVER, 3 PASSENGER)	13MM WRENCH
10	6	M8 U-NUT (YELLOW ZINC)	SOCKET EXT.
11,12	24	M8 HEX HEAD CAP SCREW (20 LONG, 4 SHORT) (YELLOW ZINC)	ALLEN WRENCH
13	24	M8 SPLIT LOCK WASHER (YELLOW ZINC)	
14	6	M8 HEX NUT (YELLOW ZINC)	
15	30	M8 FLAT WASHER (YELLOW ZINC)	
16	12	M6 HEX NUT (YELLOW ZINC)	
17	12	M6 SPLIT LOCK WASHER (YELLOW ZINC)	
18	12	M6 FLAT WASHER (YELLOW ZINC)	
19	12	M6 CARRIAGE BOLT (BLACK ZINC)	

**ANTI-SEIZE LUBRICANT MUST BE USED ON ALL STAINLESS STEEL FASTENERS TO PREVENT THREAD DAMAGE AND GALLING**

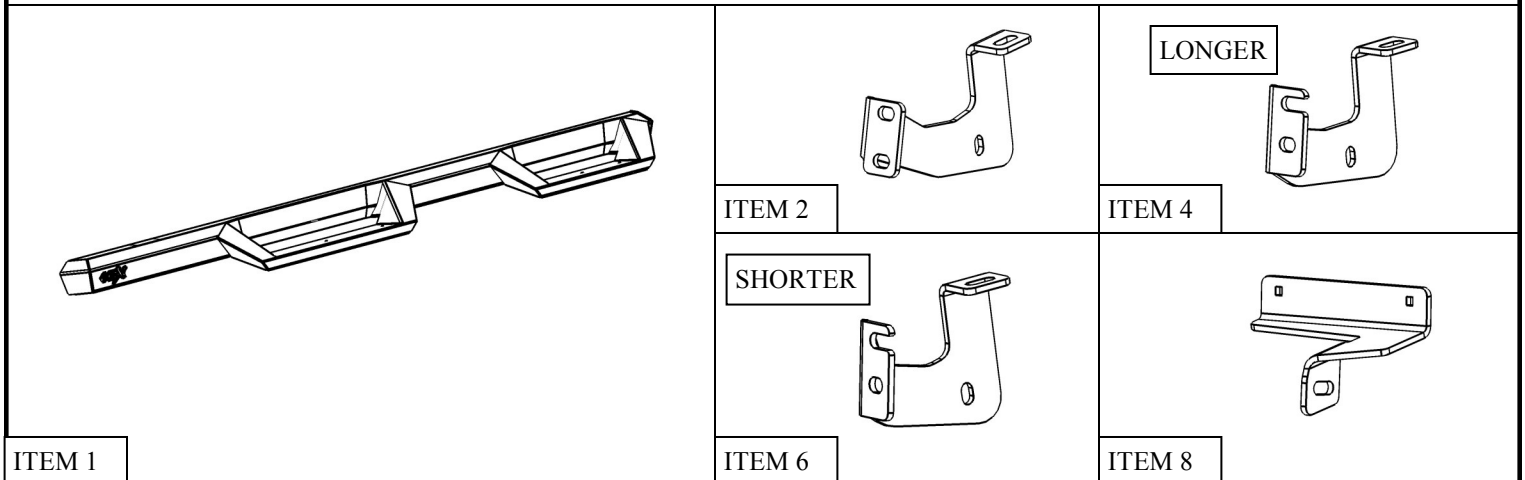

DRIVER SIDE ITEMS SHOWN, PASSENGER SIDE OPPOSITE



## PROCEDURE

1. Remove contents from box, verify if all parts listed are present and free from damage.  
Carefully read and understand all instructions before attempting installation.  
**Failure to identify damage before installation could lead to a rejection of any claim.**
2. Starting at the front mount location, locate (1) Support Bracket Driver (Item 8). Loosely secure brackets, using the supplied M6 hardware as shown in **Figure 1 and Figure 2**

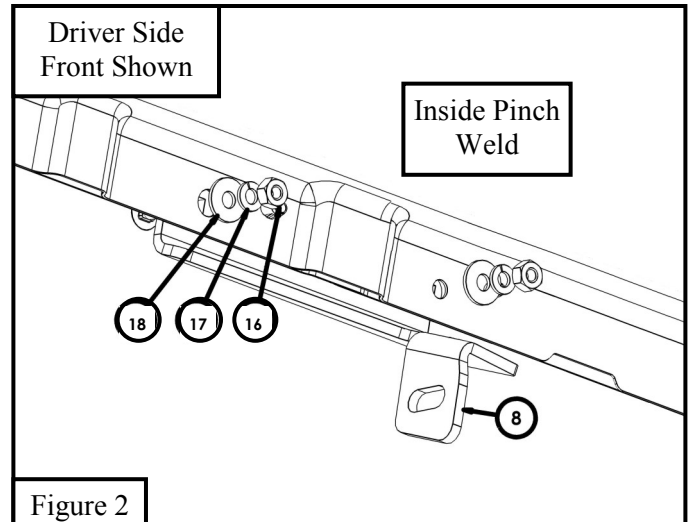
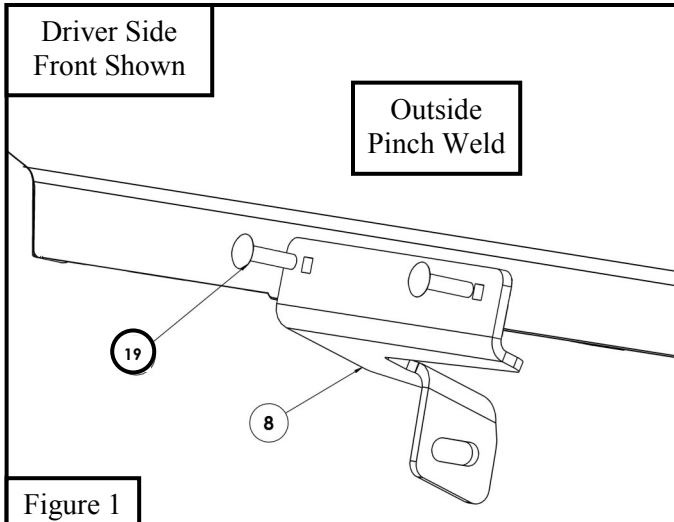

3. Starting on the drivers side loosely install Rear and Center brackets **FIRST**. Installation is similar to front mount bracket. Please refer to **Figure 3 and Figure 7** for bracket orientation and location.
4. Locate (1) Step Bar Assembly and loosely secure it onto the previously installed rear and center brackets using the provided M8 hardware. Partially insert M8 Hardware into board and slide the slotted bracket onto the bolt. See **Figure 4**
5. Torque the bolts as far as they can go while still having adjustment.
6. Then locate (1) Front Driver Side Mount Bracket (Item 2). Loosely secure bracket to vehicle and previously installed support bracket using the supplied M8 hardware as shown in **Figure 3**. [**Note:** If a threaded hole is not present use the supplied M8 U-Nut Clip (Item 10)].

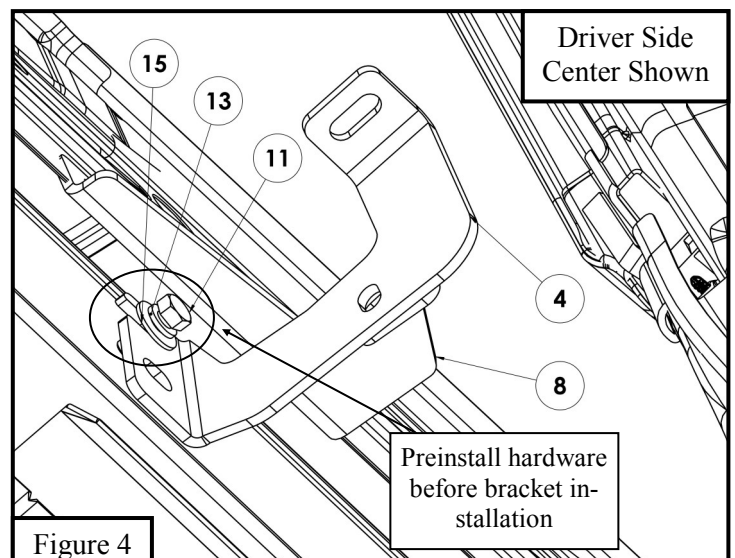
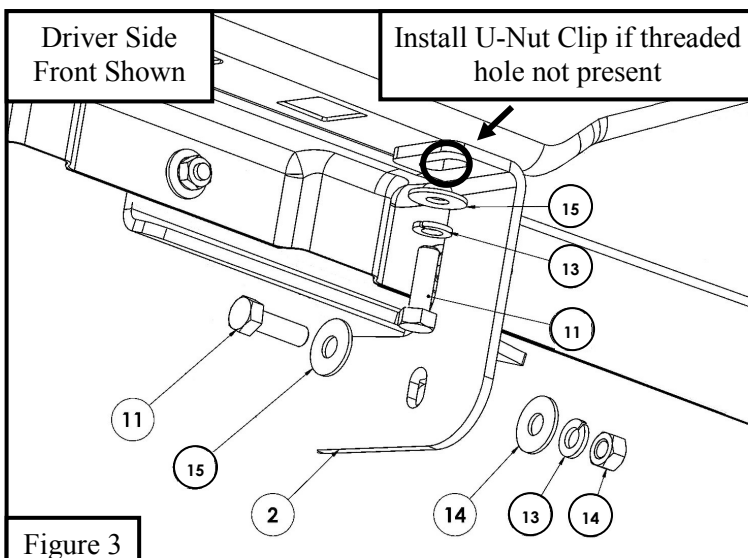

7. Before installing board to the previously installed brackets tilt backwards for easy entry into mount location. See **Figure 8**
8. Loosely Install step bars respectively to either side using the M8 hardware provided with the step bars. See **Figure 9**.

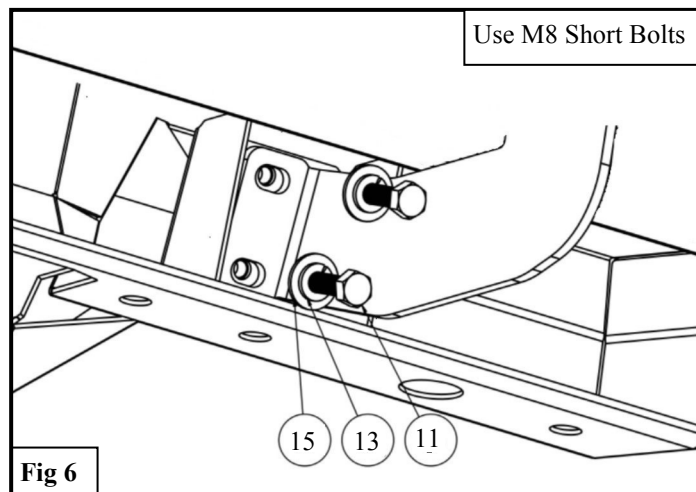
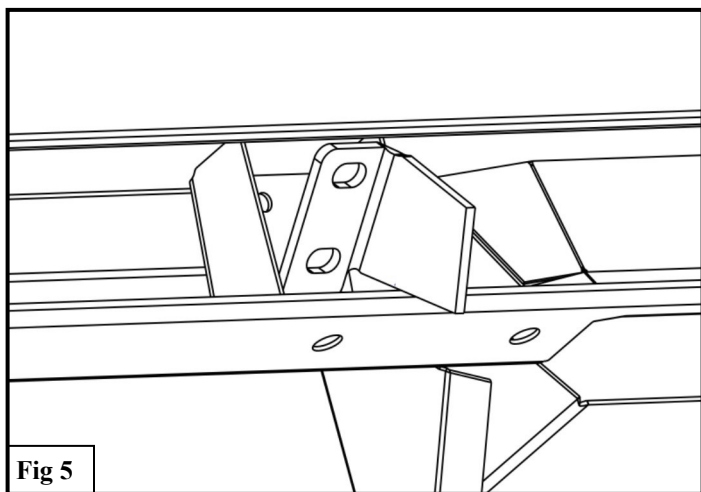

9. Repeat steps 2 - 7 for passenger side.
10. Align step bar and brackets to desired positioning then torque and tighten all: M6 Hardware to 7 ft-lbs, M8 hardware to 16 ft-lbs.

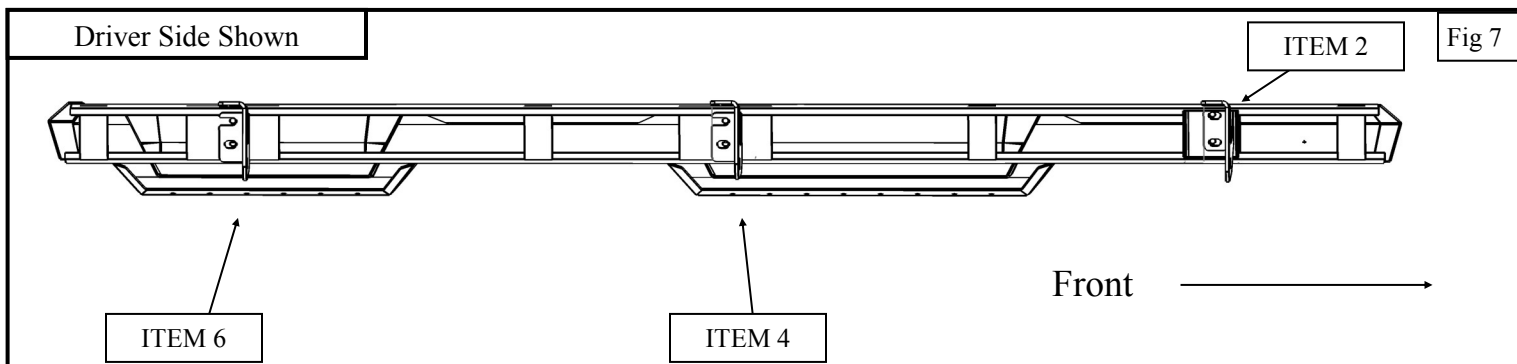

## INSTALLATION COMPLETE



### CARE INSTRUCTIONS

- REGULAR WAXING IS RECOMMENDED. DO NOT USE ANY TYPE OF POLISH OR WAX THAT MAY CONTAIN ABRASIVES
- STAINLESS STEEL PRODUCTS CAN BE CLEANED WITH MILD SOAP AND WATER. STAINLESS STEEL POLISH SHOULD BE USED TO POLISH SMALL SCRATCHES.
- GLOSS BLACK FINISHES SHOULD BE CLEANED WITH MILD SOAP AND WATER

**WESTIN**



## WARNING



Failure to follow these instructions could lead to death, personal injury, and / or property damage.

Failure to follow these instructions could lead to death, personal injury, and / or property damage.

### FASTENERS:

All Westin supplied fasteners must be utilized and installed in accordance with the installation instructions and apply torque to the specifications as defined. **DOUBLE CHECK ALL FASTENERS BEFORE INITIAL USE, AND PERIODICALLY IN THE FUTURE TO ENSURE PROPER FUNCTION AND SAFETY.**

### DRILLING:

Most Westin products do not require drilling for installation. If drilling is defined as required, use caution when drilling a vehicle. **FAILURE TO REVIEW AN AREA TO BE DRILLED MAY RESULT IN PERSONAL INJURY AND/OR INJURY TO OTHERS AS WELL AS VEHICLE DAMAGE.**

### EYE PROTECTION:

**ALWAYS WEAR SAFETY GLASSES OR GOGGLES DURING THE INSTALLATION PROCESS TO AVOID PERSONAL INJURY.**

### MAXIMUM TOWING/CARRYING CAPACITY: (if applicable)

The Westin Receiver Hitches will have a visible tow rating label affixed directly on the product. User should never exceed the vehicle manufacturers maximum tow and weight rating regardless of the capacity of the hitch. **FAILURE TO FOLLOW THESE GUIDELINES WILL VOID THE WESTIN WARRANTY AND MAY RESULT IN PERSONAL INJURY AND/OR INJURY TO OTHERS AS WELL AS VEHICLE DAMAGE.**



Learn more about running boards and step bars we have.