

# INSTALLATION INSTRUCTIONS



**GASOLINE TRUCKS ONLY  
HDX DROP STEP**

**APPLICATION:**

2007-2017 Chevy Silverado / GMC Sierra / 1500-2500-3500

Ext. / Double / Crew Cab

**PART NUMBER:**

56-13715, 56-13725

| ITEM | QUANTITY | DESCRIPTION  | TOOLS NEEDED        |
|------|----------|--|---------------------|
| 1    | 2        | STEP BAR ASSEMBLY                                  | RATCHET 1/4" & 3/8" |
| 2,3  | 2        | CENTER MOUNT BRACKET, DRIVER (2) AND PASSENGER (3) | TORQUE WRENCH       |
| 4    | 2        | MOUNTING BRACKET A                                 | 10MM SOCKET         |
| 5    | 2        | MOUNTING BRACKET B                                 | 13MM SOCKET         |
| 6*   | 1        | MOUNTING BRACKET C                                 | 13MM WRENCH         |
| 7    | 12       | M8 HEX HEAD BOLT LONG (YELLOW ZINC)                | SOCKET EXT.         |
| 8    | 12       | M8 HEX HEAD BOLT SHORT (YELLOW ZINC)               | 13MM RATCHET WRENCH |
| 9    | 24       | M8 FLAT WASHER (YELLOW ZINC)                       |                     |
| 10   | 24       | M8 LOCK WASHER (YELLOW ZINC)                       |                     |
| 11   | 12       | M8 U-NUT CLIP (YELLOW ZINC)                        |                     |

**ANTI-SEIZE LUBRICANT MUST BE USED ON ALL STAINLESS STEEL FASTENERS TO PREVENT THREAD DAMAGE AND GALLING**

**ITEM WITH ( \* ) - IS ONLY USED FOR 1500 CREW APPLICATIONS**

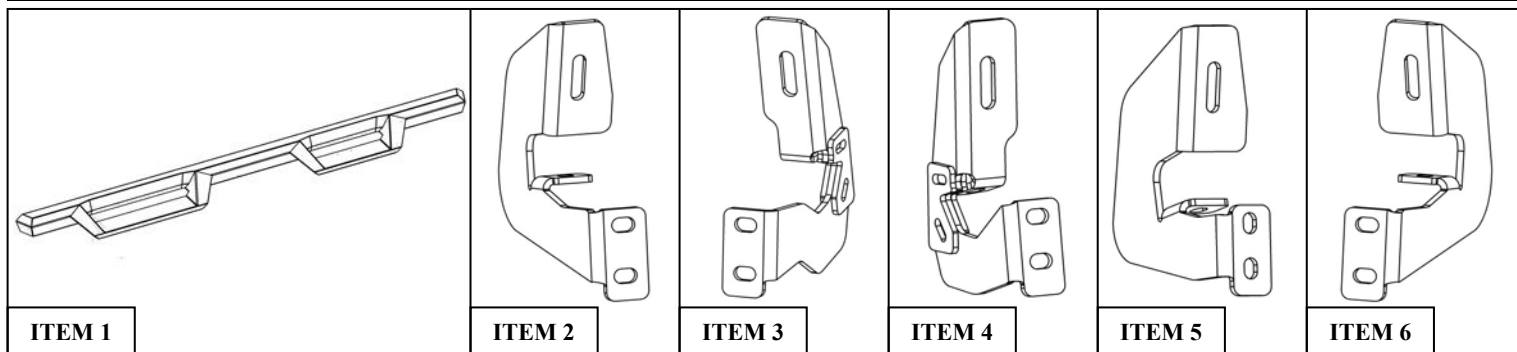

**PROCEDURE**

1. Remove contents from box, verify if all parts listed are present and free from damage. Carefully read and understand all instructions before attempting installation.  
**Failure to identify damage before installation could lead to a rejection of any claim.**
2. Starting on the driver side, remove the rubber plugs located on the rocker panel at each mounting location. See **Figure 1**.
3. **For models with welded nuts:** At each bracket mounting location on the pinch weld there should either be a welded factory nut or a hole. If there is a factory welded nut present, then the M8 U-Nut Clip (Item 11) will not be used at that location. See **Figure 2** for the factory welded nut.

**Care Instructions**

- REGULAR WAXING IS RECOMMENDED. DO NOT USE ANY TYPE OF POLISH OR WAX THAT MAY CONTAIN ABRASIVES.
- STAINLESS STEEL PRODUCTS CAN BE CLEANED WITH MILD SOAP AND WATER. STAINLESS STEEL POLISH SHOULD BE USED TO POLISH SMALL SCRATCHES.
- GLOSS BLACK FINISHES SHOULD BE CLEANED WITH MILD SOAP AND WATER.



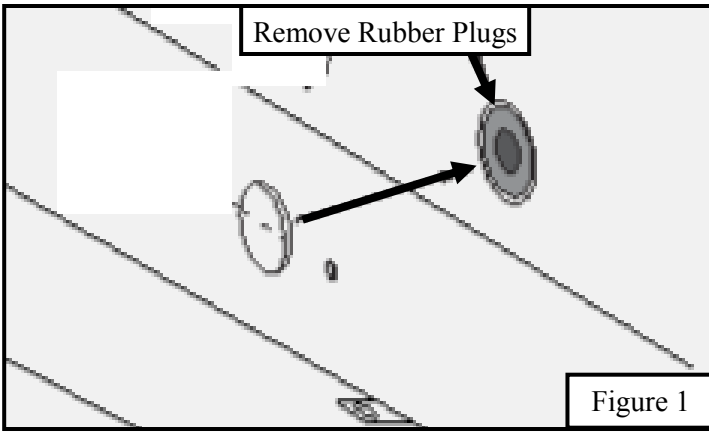

Figure 1

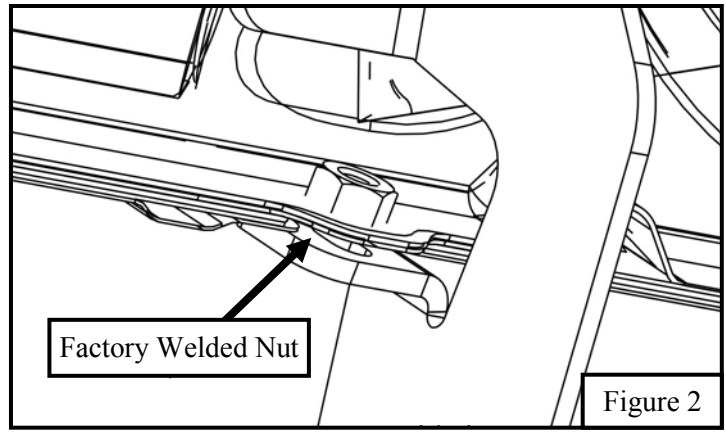
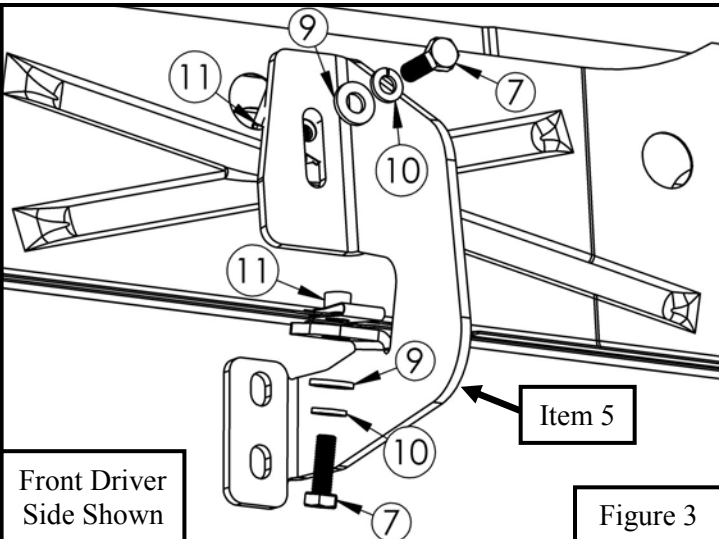

Figure 2

4. Insert (1) M8 u-nut clip (Item 11) into the hole where the rubber plug was removed. Clip (1) M8 u-nut clip onto pinch weld if no factory welded nut is present. Locate (1) Mounting Bracket B (Item 5) and loosely secure it to the rocker panel using the provided hardware: (2) M8 hex head bolt long, (2) M8 flat washer, and (2) M8 lock washer. See **Figure 3**.
5. Repeat **Step 4** for every other bracket mounting location, see **Page 3** for bracket orientation and location.
6. Locate (1) Mounting Bracket A (Item 4) and go to the front passenger side mounting location or passenger rear for 1500 crew cab models. Loosely secure mount bracket A to the rocker panel using (2) M8 hex head bolt long, (2) M8 flat washer, (2) M8 lock washer and (2) M8 u-nut clip. See **Figure 4**. Refer to **Page 3** bracket orientation figures.



Front Driver Side Shown

Figure 3

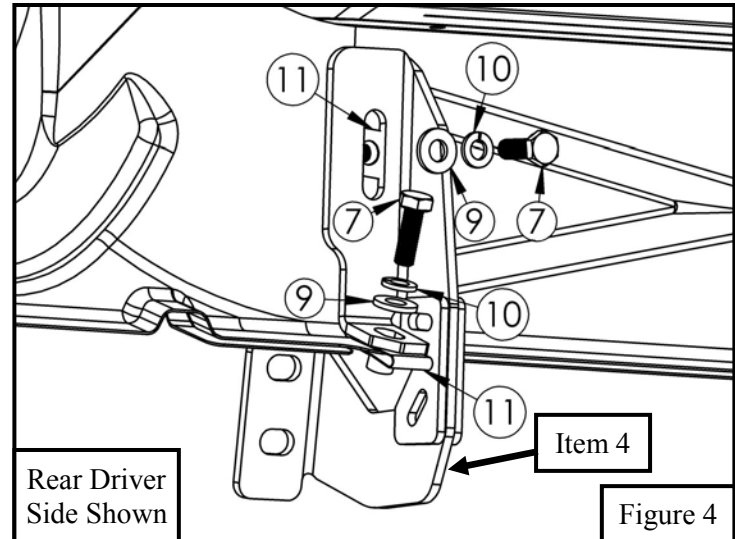

Rear Driver Side Shown

Figure 4

7. For Step Board installation, tilt board at an angle to insert brackets into mounting locations. With the previously installed mounting brackets use the supplied M8 hardware with the short M8 hex head bolt, then loosely install. See **Figures 5 & 6**.
8. Align and adjust the step bars and brackets as needed, then fully tighten all hardware: M8 to 15-18 ft-lbs.

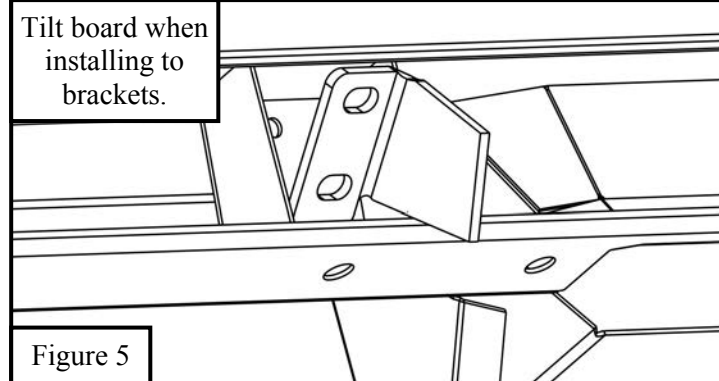

Tilt board when installing to brackets.

Figure 5

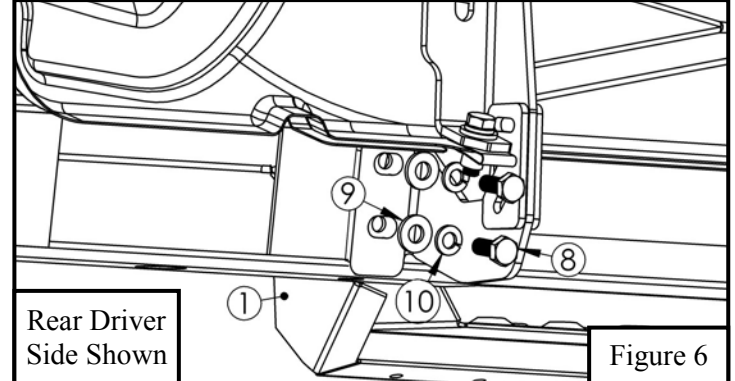

Rear Driver Side Shown

Figure 6

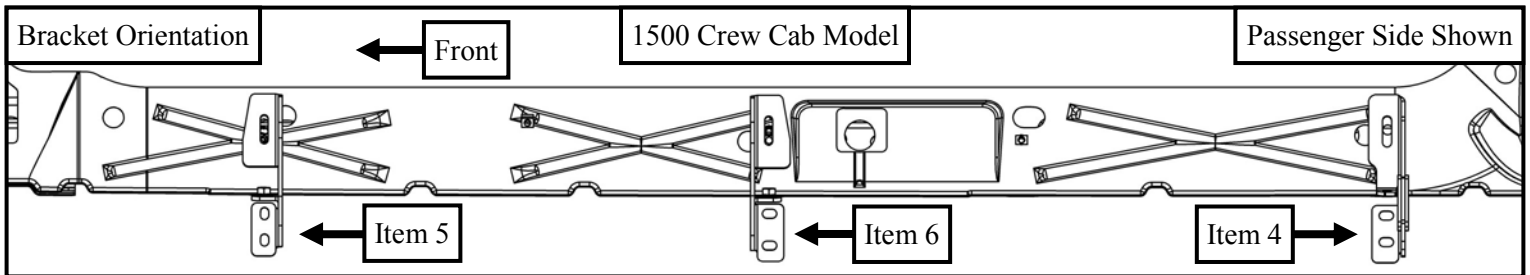
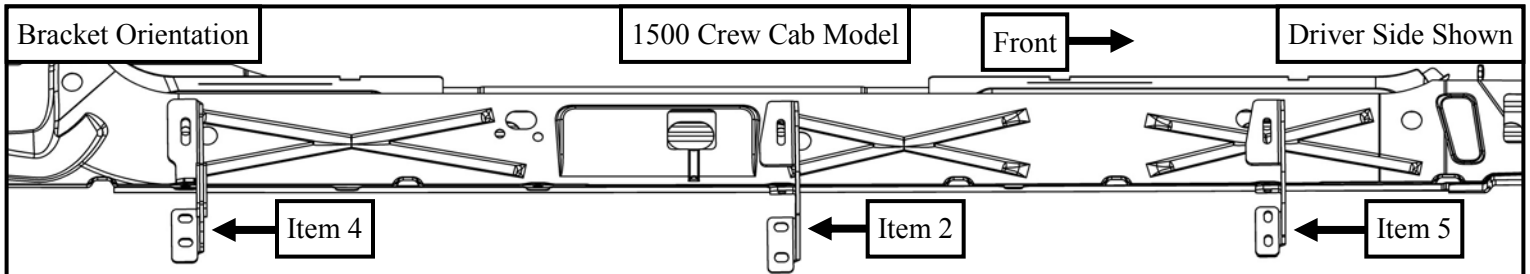
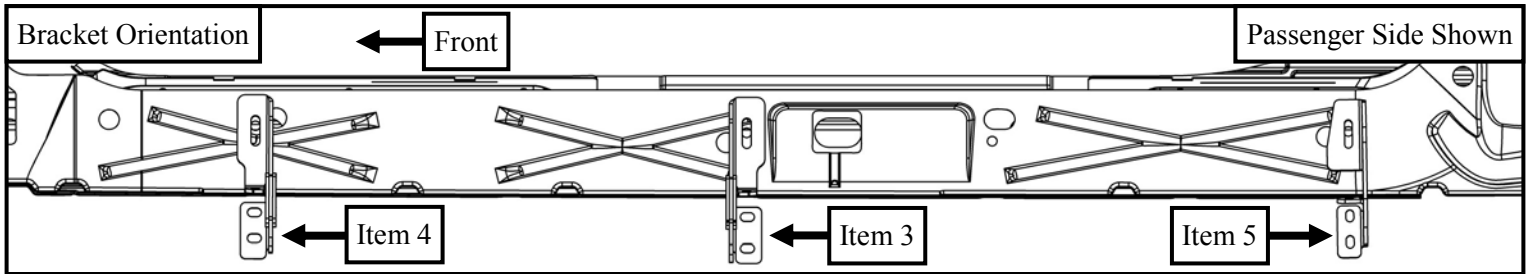
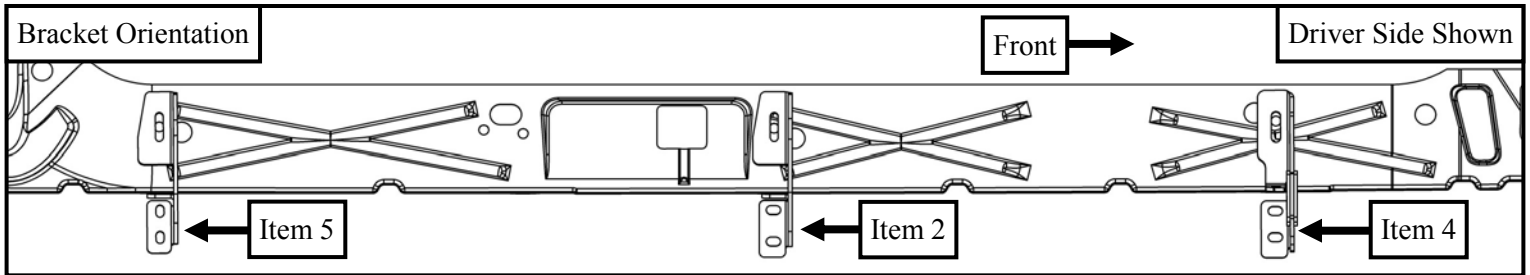

INSTALLATION COMPLETE



**WESTIN**